

# Forming

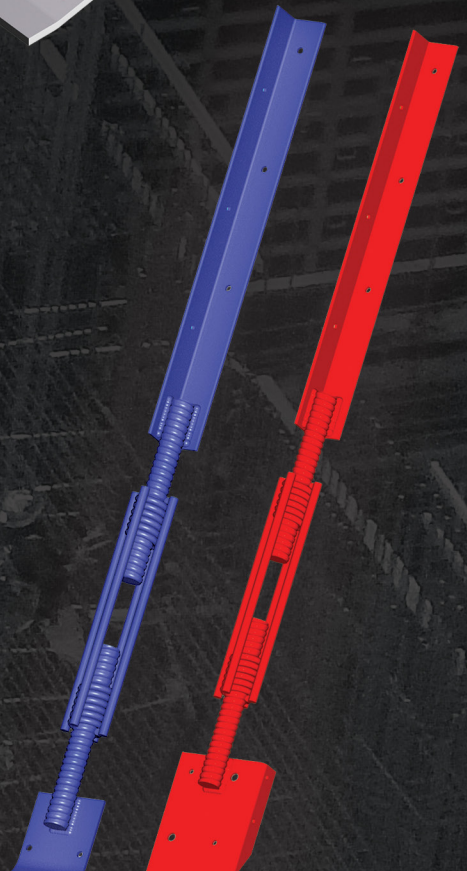

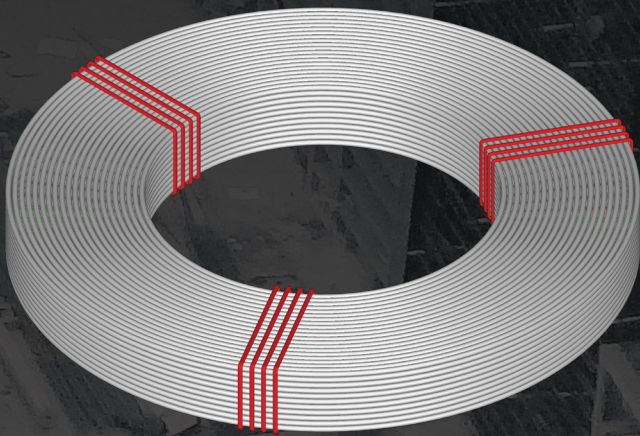
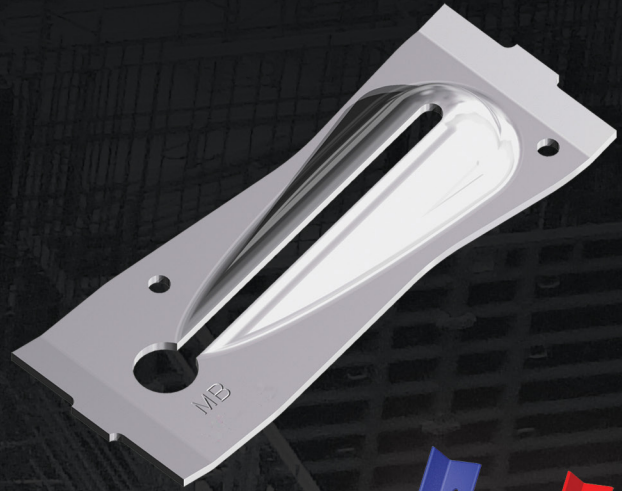

# **We are one team.** **We are Leviat.**

**Leviat is the new name of  
CRH's construction accessories  
companies worldwide.**

Under the Leviat brand, we have united the expertise, skills and resources of Meadow Burke and its sister companies to create a world leader in fixing, connecting and anchoring technology.

The products you know and trust, including Meadow Burke, will remain an integral part of Leviat's comprehensive brand and product portfolio. As Leviat, we can offer you an extended range of specialist products and services, greater technical expertise, a larger and more agile supply chain and better, faster innovation.

By bringing together CRH's construction accessories family as one global organisation, we are better equipped to meet the needs of our customers, and the demands of construction projects, of any scale, anywhere in the world.

**This is an exciting change. Join us on our journey.**

**Read more about Leviat at [Leviat.com](http://Leviat.com)**



Our product brands include:

**MB** MeadowBurke®

**H**  
HALFEN

**thermomass**®



**3,000**

employees

**60**

locations

**25**

countries

**4**

continents

Imagine. Model. Make.

[Leviat.com](http://Leviat.com)

## Table of Contents

<b>General Form Design Data</b>		
Safety Considerations ..... 4	General Form Design Data ..... 5	Common Forming Lumber Properties..... 9
<b>Meadow Burke Snap Ties</b>		
Snap Tie - Standard ..... 15	Snap Tie Accessories ..... 19	Residential SnapTies..... 20
<b>Single Waler System</b>		
Waler Brackets ..... 21	Single Waler Forming Application ..... 25	
Form Aligners ..... 24	Single Waler Bracket Installation ..... 26	
<b>Light, Medium and Heavy Forming Products</b>		
Pencil Rod ..... 30	Coil Ties..... 32	
<b>Form Tie Accessories and Working Parts</b>		
Coil Nuts..... 36	Coil Bolt..... 38	Cone-Fast Cones ..... 40
Washers ..... 37	Coupler..... 40	Plylag ..... 41
<b>Form Anchorage</b>		
Coil Inserts for Form Anchorage ..... 44		
<b>Euro Medium and Heavy Forming Products</b>		
Euro Taper Tie ..... 52	Euro Bar - Hot Rolled ..... 54	Euro Swivel Wing Nut..... 55
Euro Threaded She Bolt ..... 53	Euro Nut Washer..... 54	Euro Angle Weld Bracket..... 55
Euro Bar - Cold Rolled..... 54	Euro Threaded Wing Nut ..... 55	
<b>Structural Movement Solutions</b>		
<b>Permanent Movement: Double Shear Dowel</b>	Joint Solutions ..... 59	Installation..... 61
Advantages..... 58	Reinforcement Details..... 60	
<b>Temporary Movement: Lockable Dowel</b>	Performance Data..... 66	Reinforcement Details..... 68
Advantages..... 62	Dimensions..... 67	Installation..... 69
Applications..... 63		
<b>Medium and Heavy Forming Miscellaneous</b>		
Medium and Heavy Forming Misc ..... 71	Form Hangers ..... 73	Screeding ..... 74

1 - 14

15 - 20

21 - 28

29 - 34

35 - 42

43 - 50

51 - 56

57 - 70

71 - 76

## SAFETY CONSIDERATION

Meadow Burke recommends that provisions outlined in the American Concrete Institute publication, “Recommended Practice for Concrete Formwork” (ACI 347), be strictly adhered to by all persons and organizations working in the concrete construction industry. Meadow Burke also strongly advises that the safety factors shown in the Minimum Safety Factors of Formwork Accessories Table be followed. If there are any unusual job site conditions, such as shock, impact, vibration, etc., safety factors must be increased to ensure worker protection.

MINIMUM SAFETY FACTORS OF FORMWORK ACCESSORIES		
Accessory	Safety Factor	Type of Construction
Form Tie	2:1	All formwork
Form Hangers	2:1	Supporting form, concrete weight and live loads
Form Anchor	2:1	Supporting form weight and concrete pressure only
Form Anchor	3:1	Supporting form weight, concrete pressure, live loads and impact
Insert Used as Form Tie	2:1	Precast concrete panels used as formwork Heavy cantilever formwork

### RATED LOADS

It is apparent from the Table that the safety factor applied to a given product is a variable depending on the degree of hazard involved in the application of the product. The user of the products in this publication must determine the applicable safety factor for the products as a function of its use as described in the Table.

Product load ratings are based on the ultimate strength of the metal. Safe working loads displayed in this publication are approximate minimum values. Due to the variety of applications, the responsibility of selecting appropriate safety factors is up to the user of the product. Any recalculation of safe working loads due to a change in the approximate minimum safety factor should include a careful analysis of all hardware used in the application and the anticipated concrete strength involved. If any doubt, contact a Meadow Burke Service Center for clarification.

### PRODUCT LIABILITY

Meadow Burke stresses that the products in this publication are to be used by experienced workers with competent supervision. If an end user does not have qualified and experienced workers or installers, or does not have the technical expertise in the application of the product or does not know the consequences from improper use of the product; do not use the product without consulting a Meadow Burke Service Center.

### WORN WORKING PARTS

It is the responsibility of the user to continually inspect working parts and hardware for wear. If wear is present, the product should be discarded. Do not attempt to straighten bent bolts; they should be scrapped. Discard any bolts known to have been used at loads of 70% or more of ultimate capacity.

### WELDING

Since it is impossible to control field conditions, Meadow Burke does not guarantee any product that has been altered in any way after leaving its factory of origin. This includes any type of welding or bending. Do not weld any Meadow Burke product without the assurance from a qualified engineer that the weld is in a non-critical area. Welding can cause embrittlement at the load point and greatly reduce load carrying capacity.

**CAUTION:** It is extremely important for the user of Meadow Burke products to evaluate product applications, determine the appropriate minimum safe working loads and control all field conditions to prevent loads in excess of the determined minimum safe working loads.

**WARNING:** Improper application or faulty installation of any product displayed in this publication can cause hazardous conditions that can result in serious injury or death.

## GENERAL FORM DESIGN DATA

### PRODUCT DESIGN

Meadow Burke reserves the right to change product designs and/or product safe load ratings at any time without prior notice.

### FACTORS AFFECTING LATERAL PRESSURE ON FORMWORK

#### WEIGHT OF CONCRETE

The weight of concrete is a direct influence since hydrostatic pressure at any point in a fluid is created by the weight of the superimposed fluid. Liquid (hydrostatic) pressure is the same in all directions at a given depth in the fluid and acts at right angles to any surface that confines it. If concrete acted as a true liquid, the pressure would be equal to the density of fluid times the depth, to the point at which the pressure was being considered. However, concrete is a mixture of solids and water whose behavior only approximates that of liquid for a limited time.

#### RATE OF PLACEMENT

The average rate of rise of the concrete in the form is referred to as the rate of placement. The rate of placement has a primary effect on lateral pressure and the maximum lateral pressure is proportional to the rate of placement, up to a limit equal to the full fluid pressure. As the concrete is being placed, the lateral pressure at a given point increases as the concrete depth above the point increases. Finally, by consolidation and/or stiffening, the concrete will support itself and will no longer cause lateral pressure on the form.

### CONCRETE VIBRATION

Internal vibration is a primary method of consolidating concrete in the form. It results in temporary, local lateral pressures that are 10 to 20 percent greater than those caused by simple spading. Since internal vibrating is an accepted common practice, forms should be designed to handle the added pressures.

Revibration and external vibration are other types of vibration used in certain types of construction. Revibration and external vibration methods produce higher lateral loads than the internal vibration process and require specially designed forms. External vibration (also referred to as form vibration) is accomplished by attaching vibrators to the outside of the form. The form itself is vibrated to hammer the form against the concrete. The frequency/amplitude of external vibration must be regulated to consolidate the concrete but not too strong to damage the form. Revibration is the process where a vibrator is forced down through the upper placement into layers of concrete that have stiffened or have nearly reached initial set. Localized lateral pressures, up to 300 psf/ft of head of concrete, have been recorded using vigorous revibration. Neither revibration nor external vibrations have been sufficiently investigated to be expressed in a standard formula. Pressure formulae in this publication are limited to concrete vibrated internally at the time of placement.

## CONCRETE TEMPERATURE

The temperature of the concrete at the time of placement has an important influence on pressure due to the affect it has on the setting time of the concrete. At lower concrete temperatures, the concrete takes longer to stiffen, so a greater depth of concrete can be placed before it becomes firm enough to be self-supporting. The greater liquid head results in higher lateral pressures. This is an important form design consideration when anticipating concrete placement in cold weather, with fly ash replacement or when using retarding admixtures.

## OTHER VARIABLES

There are numerous other variables that will affect the lateral pressure in the form. Such things as the consistency of the concrete, the amount and location of reinforcing steel, ambient temperature, pore water pressure, aggregate

size, placing procedures, type of cement, depth of placement, cross-section of the form, smoothness of the form faces and permeability of the form can all have an effect on the lateral pressure in the form. However, under normal conditions and forming practices, the range of these variable effects is generally small and is usually neglected.

On the other hand, the use of fly ash or other pozzolan as a cement replacement at low ambient temperatures or with a retarding mixture can have a significant effect on lateral pressure. Likewise, superplasticizing admixtures and the retarders themselves can have a substantial effect on the lateral pressure. These conditions must be given due consideration during the form design process.

## LATERAL PRESSURE VALUES FOR FORM DESIGN

### VERTICAL WALL FORMS

The American Concrete Institute Committee 347-04 (Chapter 2) has developed the formulas below for maximum lateral pressure on the form, prescribed temperatures, rate of placement, vibration, concrete weight and slump. They are working formulas based on available data and are recommended for form design. No claim is made for their theoretical precision.

Walls with Rate of Placement (R) not exceeding 7 ft/hr and wall height not exceeding 14 ft and columns:

$$p = (150 + 9,000R/T) C_c C_w \dots\dots\dots 2.1$$

Maximum = wxh

Minimum = 600C<sub>w</sub>psf

Walls with Rate of Placement (R) not exceeding 7 ft/hr and wall heights exceeding 14 ft, and for all walls with a placement rate of 7 to 15 ft/hr:

$$p = C_c C_w (150 + 43,400/T + 2,800R/T) \dots\dots\dots 2.2$$

Maximum = wxh

Minimum = 600C<sub>w</sub>psf

Where:

p = maximum lateral pressure (psf)

R = rate of placement (ft/hr)

T = temperature of the concrete

h = maximum height of fresh concrete

w = unit weight of concrete (pcf)

C<sub>w</sub> = unit weight coefficient, 1.0 for w = 150 pcf

C<sub>c</sub> = chemistry coefficient

The formulae are applicable for internally vibrated structural concrete of normal weight and density, produced with Type I cement and containing no pozzolans or admixtures and with a slump of less than four inches. Good concrete placing procedures are assumed; for example, vibration is used for consolidation only and is limited to four (4) feet below the surface of the concrete. The formulae assume that concrete “set” will occur as expected, usually in one hour. Do not use design pressures in excess of  $w \times h$ .

Table 2.3 is based on Formulae 2.1 and 2.2 and wall heights not exceeding 14 ft. It shows the maximum lateral pressures to be used for form design for rates of placement up to 10 ft/hr and concrete temperatures from 40° to 90° F.

Since studs and sheathing are usually uniform throughout their height, only the maximum pressure value is required for their design. However, wales and tie spacing may be increased near the top of the form due to lower lateral pressure there.

1 - 14

MAXIMUM LATERAL PRESSURE FOR DESIGN OF VERTICAL WALL FORMS						
Rate of Placement, R (ft per hr)	p, Maximum Lateral Pressure, psf, for Temperature indicated, max wall height = 14 ft.					
	90° F	80° F	70° F	60° F	50° F	40° F
1						
2	600	600	600	600	600	600
3	600	600	600	600	600	825
4	600	600	664	750	600	1050
5	650	713	793	900	600	1275
6	750	825	921	1050	600	1500
7	850	938	1050	1200	600	1725
8	881	973	1090	1247	600	1795
9	912	1008	1130	1293	600	1865
10	943	1043	1170	1340	600	1935

NOTE: Do not use design pressures in excess of  $w \times h$  of fresh concrete in forms.

Table 2.3

A wall form 14' high may be concreted at  $R=10'$  per hour with normal weight concrete (150 pcf), when the temperature is 60°F. Maximum pressure by Formula 2.2 or from Table above is 1340 psf. Since this is comparable to fluid pressure up to the time concrete begins to stiffen appreciably, any point within  $1340/150 = 9'$  from the top of the form will have proportionately less pressure than the maximum. The 1340 maximum is used for design throughout the remaining 5' of the form.

Keep in mind that the pressure given in the formula (and shown in the sketch to right) represents an envelope of maximum pressure exerted during the total time required to fill the form. The diagram does not show distribution of pressure over the form surface at any one time.

In the case of a wall form only 6' high, concrete at the same  $R = 10'$  per hour and temperature of 60° F, the limit of  $w \times h$  applies since it is less than the value given by the formula. The envelope of maximum pressure then is as shown to the right.

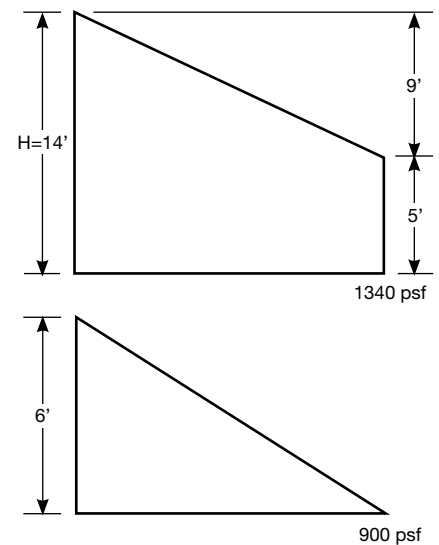

## TYPICAL TIE LOCATIONS AND FORM DESIGN

### NOTES, CAUTIONS AND WARNINGS:

a. If actual rate of placement exceeds design rate of placement, a snap tie or form failure may occur.

b. If “set” time of concrete is altered by additives, i.e. entrained air, pozzolans, fly ash or other retarders, excess vibration or any other means of alterations or incorrect temperature allowances, then one of the lower row ties will likely fail due to an over-load condition.

c. Remember, a full liquid head of 150h can develop if concrete “set” does not occur when expected (or if concrete “set” is interrupted by excessive vibration). If, for example, a 12’ wall is poured in 3 hours at a rate of 4’ per hour design, and a form tie (or ties) fails, usually in the 2nd or 3rd row from the bottom, then the concrete probably did not “set” when expected, and a full or partial liquid head (150h) developed, causing much higher pressure than expected.

Note: Normal concrete, 150 lbs. per cu. foot, without any additives, retarders or excessive vibration, at 70°F to 80°F will “set” in about 1-¾ hours. It is possible for concrete “set” to take up to 3 hours under certain conditions. Forming contractors should exercise the utmost caution when evaluating expected “set” time. It is the least controllable of all parameters involved.

Caution: It takes the concrete more than one hour to “set” under the following conditions:

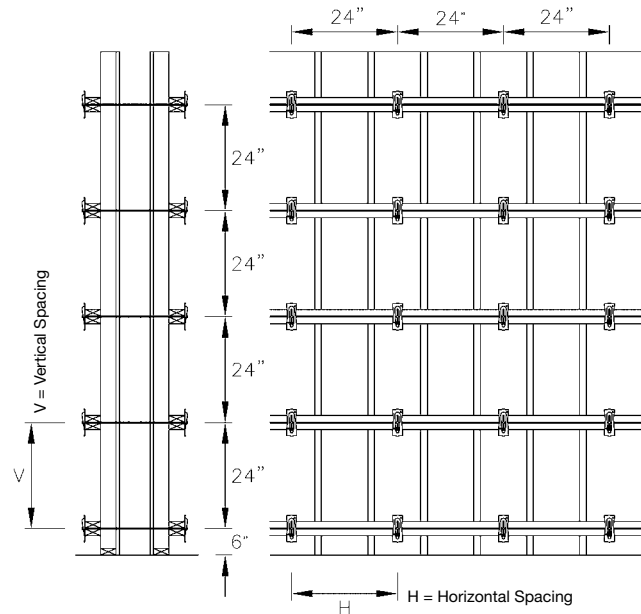

- The addition of admixtures or pozzolans
- The addition of retarders or entrained air
- Actual temperature is less than design temperature
- Excessive vibration to depths greater than four feet below concrete surface
- Vibrator used to move concrete laterally in the form
- Revibration of prior vibrated areas
- Concrete slump in excess of four inches
- Use of cement other than Type 1 Portland Cement

**TYPICAL TIE LOCATION AND FORM DESIGN**

Tie Spacing			Recommended Form Design			R = Rate of placement and ambient temperature (°F)						Concrete Pressure, psf	Actual Tie Load, lbs
Horizontal Spacing	Vertical Spacing	Tie Area ft²	Sheathing	Stud Size & Spacing	Wales	40°	50°	60°	70°	80°	90°		
<b>2250 LB SAFE WORK LOAD SNAP TIES</b>													
3'-0"	1'-0"	3	5/8 Plyform 3/4 Plyform	2x4@10"o/c 2x4@11"o/c	DBL 2x4/ SGL 2 x 6	2'-8"	3'-4"	4'-0"	4'-8"	5'-4"	6'-0"	750	2250
2'-0"	1'-4"	2.66	5/8 Plyform 3/4 Plyform	2x4@9"o/c 2x4@10"o/c	DBL 2x4/ SGL 2 x 6	3'-1"	3'-10"	4'-7"	5'-4"	6'-2"	6'-11"	846	2250
1'-6"	2'-0"	3	5/8 Plyform 3/4 Plyform	2x4@10"o/c 2x4@11"o/c	SGL 2 x 6	2'-8"	3'-4"	4'-0"	4'-8"	5'-4"	6'-0"	750	2250
<b>3250 LB SAFE WORK LOAD SNAP TIES</b>													
3'-0"	1'-4"	4	5/8 Plyform 3/4 Plyform	2x4@9"o/c 2x4@10"o/c	DBL 2 x 6	2'-11"	3'-8"	4'-4"	5'-1"	5'-10"	6'-7"	813	3250
2'-6"	2'-0"	5	5/8 Plyform 3/4 Plyform	2x4@10"o/c 2x4@12"o/c	DBL 2 x 6	2'-2"	2'-9"	3'-4"	3'-10"	4'-4"	5'-0"	650	3250
2'-0"	2'-8"	5.34	5/8 Plyform 3/4 Plyform	2x4@10"o/c 2x4@12"o/c	DBL 2x4/ SGL 2 x 6	2'-0"	2'-6"	3'-0"	3'-6"	4'-0"	4'-7"	609	3250

1. Table is based on a concrete “set” time of one hour. If “set” times of more than one hour are anticipated, adjust pour rates accordingly.
2. Table is based on equation 2.1 on page 4.
3. Stud spacing based on plywood face grain parallel to span and APA rated Class 1 Plywood.
4. Stud and waler design based on SYP #2 lumber.

## COMMON FORMING LUMBER PROPERTIES

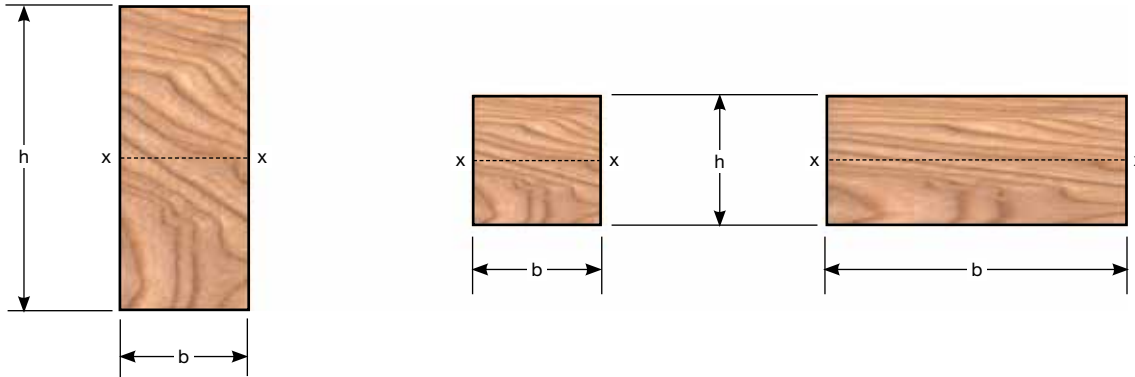

1 - 14

### PROPERTIES OF STRUCTURAL LUMBER

Nominal Size (in.) bxh	American Standard Size (in.) bxh S4S* 19% Maximum Moisture	Area of Section a = bh, (sq in.)		Moment of Intertia (in.) $I = \frac{bh^3}{12}$		Section Modulus (in.) $S = \frac{bh^2}{6}$		Board Feet (per lineal ft of piece)	Approx. Weight (lbs per lineal ft)†
		Rough	S4S	Rough	S4S	Rough	S4S		
4 x 2	3 1/2 x 1 1/2	5.89	5.25	1.30	0.98	1.60	1.31	2/3	1.5
6 x 2	5 1/2 x 1 1/2	9.14	8.25	2.01	1.55	2.48	2.06	1	2.3
8 x 2	7 1/4 x 1 1/2	11.98	10.87	2.64	2.04	3.25	2.72	1 1/3	3.0
10 x 2	9 1/4 x 1 1/2	15.23	13.87	3.35	2.60	4.13	3.47	1 2/3	3.9
12 x 2	11 1/4 x 1 1/2	18.48	16.87	4.07	3.16	5.01	4.21	2	4.7
2 x 4	1 1/2 x 3 1/2	5.89	5.25	6.45	5.36	3.56	3.06	2/3	1.5
2 x 6	1 1/2 x 5 1/2	9.14	8.25	24.10	20.80	8.57	7.56	1	2.3
2 x 8	1 1/2 x 7 1/4	11.98	10.87	54.32	47.63	14.73	13.14	1 1/3	3.0
2 x 10	1 1/2 x 9 1/4	15.23	13.87	111.58	98.93	23.80	21.39	1 2/3	3.9
2 x 12	1 1/2 x 11 1/4	18.48	16.87	199.31	177.97	35.04	31.64	2	4.7
3 x 4	2 1/2 x 3 1/2	9.52	8.75	10.42	8.93	5.75	5.10	1	2.4
3 x 6	2 1/2 x 5 1/2	14.77	13.75	38.93	34.66	13.84	12.60	1 1/2	3.8
3 x 8	2 1/2 x 7 1/4	19.36	18.12	87.74	79.39	23.80	21.90	2	5.0
3 x 10	2 1/2 x 9 1/4	24.61	23.12	180.24	164.89	38.45	35.65	2 1/2	6.4
3 x 12	2 1/2 x 11 1/4	29.86	28.12	321.96	296.63	56.61	52.73	3	7.8
4 x 4	3 1/2 x 3 1/2	13.14	12.25	14.39	12.50	7.94	7.15	1 1/3	3.4
4 x 6	3 1/2 x 5 1/2	20.39	19.25	53.76	48.53	19.12	17.65	2	5.3
4 x 8	3 1/2 x 7 1/4	26.73	25.38	121.17	111.15	32.86	30.66	2 2/3	7.0
4 x 10	3 1/2 x 9 1/4	33.98	32.38	248.91	230.84	53.10	49.91	3 1/3	9.0

\* Rough dry sizes are 1/8" larger, both dimensions.

† Based on a unit weight value of 40 lb. per cu. ft. Actual weights vary depending on species and moisture content.

Data supplied by the National Forest Products Association

## FORM LOADING IN POUNDS/SQ. FOOT FOR INCREMENTAL SLAB THICKNESS\*

FORM LOADING DATA								
Concrete Weight (lbs per sq ft)	Slab Thickness							
	2 in.	4 in.	6 in.	8 in.	10 in.	12 in.	14 in.	16 in.
100	67	84	100	117	134	150	167	184
115	70	89	108	127	146	165	185	204
125	71	92	113	134	155	175	196	217
135	73	95	118	140	163	185	208	230
150	75	100	125	150	175	200	225	250

\*Values above include 50 psf live load for construction loads. Formwork dead load is not included.

### Safe Spacing ( $\ell$ ) in Inches of Supports for Plywood Sheathing

Continuous Over Four or More Supports

$\ell_{max} = \ell/360$ , but not to exceed  $1/16$ "

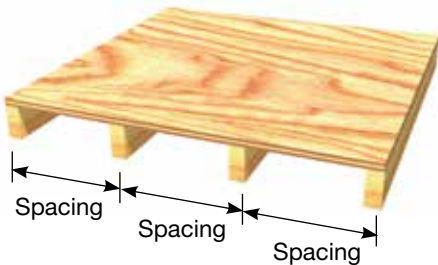

Sanded thickness, panel grain parallel to span

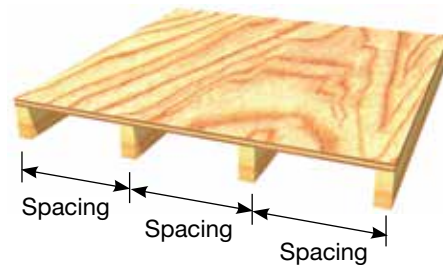

Sanded thickness, panel grain perpendicular to span.

Pressure or Load (lbs per sq ft)	TABLE BASED ON APA RATED PLYWOOD CLASS 1							
	$F_s = 72$ psi		$F_b = 1930$ psi		$E_s = 1500000$ psi		$E = 1650000$ psi	
	Sanded Thickness, Face Grain Parallel to Span				Sanded Thickness, Face Grain Perpendicular to Span			
	1/2 in.	5/8 in.	3/4 in.	1 in.	1/2 in.	5/8 in.	3/4 in.	1 in.
75	21	24	26	31	14	16	21	28
100	19	22	24	29	13	14	19	26
125	18	21	23	27	12	13	19	24
150	17	20	22	26	11	12	17	23
175	15	19	21	25	10	11	15	22
200	15	18	20	24	10	11	15	21
300	13	15	18	21	8	9	12	19
400	12	13	15	20	7	8	11	17
500	11	12	14	18	7	7	10	14
600	10	11	13	16	6	7	9	13
700	9	10	12	15	5	6	8	12
800	8	10	11	14	4	5	7	11
900	8	9	10	13	4	4	6	11
100	7	8	10	13	3	4	5	10

Safe Spacing ( $\ell$ ) in Inches of Supports for Joists, Studs, etc.  
Single Span

$$\ell_{\max} = \ell/360, \text{ but not to exceed } \frac{1}{4}''$$

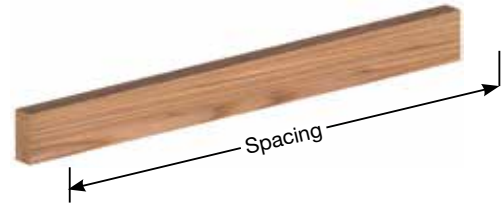

1 - 14

### SIMPLE SPAN

Equivalent Uniform Load (lbs per lineal ft)	SIMPLE SPAN SINGLE-PLY WALES							
	E = 1,600,000 psi							
	Nominal Size of S4S Lumber							
	2 x 4	2 x 6	2 x 8	2 x 10	2 x 12	3 x 6	4 x 4	4 x 8
	Fb (psi) =							
	1500	1250	1200	1050	975	1250	1500	1200
100	58	91	112	135	156	104	77	139
200	46	73	94	113	131	86	61	117
300	40	61	78	102	118	75	54	105
400	36	52	68	88	103	68	49	98
500	32	47	61	79	92	61	45	93
600	30	43	55	72	84	55	43	85
700	27	39	51	66	78	51	40	78
800	26	37	48	62	73	48	39	73
900	24	35	45	58	69	45	37	69
1000	23	33	43	55	65	43	35	65
1100	22	31	41	53	62	41	33	62
1200	21	30	39	51	59	39	32	60
1300	20	29	37	49	57	37	31	57
1400	19	28	36	47	55	36	30	55
1500	19	27	35	45	53	35	29	53
1600	18	26	34	44	51	34	28	52
1700	17	25	33	42	50	33	27	50
1800	17	24	32	41	48	32	26	49
1900	16	24	31	40	47	31	25	47
2000	16	23	30	39	46	30	25	46
2100	16	23	29	38	45	29	24	45
2200	15	22	29	37	44	29	24	44
2300	15	22	28	36	43	28	23	43
2400	15	21	27	36	42	27	22	42
2500	14	21	27	35	41	27	22	41
2600	14	20	26	34	40	26	22	40
2700	14	20	26	34	39	26	21	40
2800	13	19	25	33	39	25	21	39
2900	13	19	25	32	38	25	20	38
3000	13	19	24	32	37	24	20	38

1. All values based on 2005 NDS for S.Y.P. #2  $C_D = 1.45$ ,  $C_{M,B} = 0.85$  (1.0 for 2 x 10 & 2 x 12),  $C_{M,V} = 0.97$ ,  $C_{M,E} = 0.9$
2. Multi-spans continuous over 3 spans or 4 supports.
3.  $\ell_{\max} = \ell/360$ , does not exceed  $\frac{1}{4}''$
4. All values based on worst case of deflection, bending or shear.
5. All values above bold line are controlled by deflection. Bending and shear govern below.

Safe Spacing ( $\ell$ ) in Inches of Supports for Joists, Studs, etc.  
Continuous Over Three or More Supports

$$\phi_{max} = \ell/360, \text{ but not to exceed } \frac{1}{4}''$$

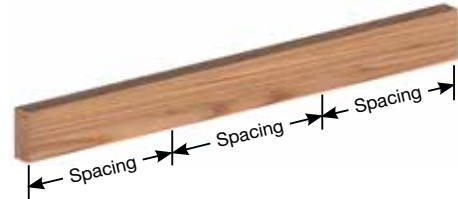

### MULTI-SPAN SINGLE WALES CONTINUOUS OVER 3-SPANS OR 4 SUPPORTS

Equivalent Uniform Load (lbs per lineal ft)	MULTI-SPAN SINGLE-PLY WALES							
	E = 1,600,000 psi							
	Nominal Size of S4S Lumber							
	2 x 4	2 x 6	2 x 8	2 x 10	2 x 12	3 x 6	4 x 4	4 x 8
	Fb (psi) =							
	1500	1250	1200	1050	975	1250	1500	1200
100	72	107	131	158	183	121	94	163
200	57	83	107	133	154	102	76	137
300	47	68	88	114	133	88	66	123
400	41	59	76	98	115	76	60	115
500	36	52	68	88	103	68	56	104
600	33	48	62	80	94	62	51	95
700	31	44	57	74	87	57	47	88
800	29	41	53	69	81	53	44	82
900	27	39	50	65	77	50	41	77
1000	26	37	48	62	73	48	39	73
1100	24	35	46	59	69	46	37	70
1200	23	34	44	57	66	44	36	67
1300	22	32	42	54	64	42	34	64
1400	21	31	40	52	61	40	33	62
1500	20	30	39	51	59	39	32	60
1600	19	29	38	49	57	38	31	58
1700	18	28	37	47	56	37	30	56
1800	17	27	35	46	54	35	29	54
1900	17	26	35	45	53	35	28	53
2000	16	25	34	43	51	34	28	52
2100	15	24	32	41	50	33	27	50
2200	15	23	31	40	49	32	26	49
2300	14	23	30	38	47	31	26	48
2400	14	22	29	37	45	31	25	47
2500	13	21	28	36	44	30	25	46
2600	13	21	27	35	43	29	24	45
2700	13	20	27	34	42	29	24	44
2800	12	20	26	33	40	28	23	44
2900	12	19	25	32	39	28	23	43
3000	12	19	25	32	38	27	22	42

1. All values based on 2005 NDS for S.Y.P. #2  $C_D = 1.45$ ,  $C_{M,B} = 0.85$  (1.0 for 2 x 10 & 2 x 12),  $C_{M,V} = 0.97$ ,  $C_{M,E} = 0.9$
2. Multi-spans continuous over 3 spans or 4 supports.
3.  $\phi_{max} = \ell/360$ , does not exceed  $\frac{1}{4}''$
4. All values based on worst case of deflection, bending or shear.
5. All values above bold line are controlled by deflection. Bending and shear govern below.

Safe Spacing ( $\ell$ ) in Inches of Supports for  
Double Wales Single Span

$\Delta_{max} = \ell/360$ , but not to exceed  $1/4"$

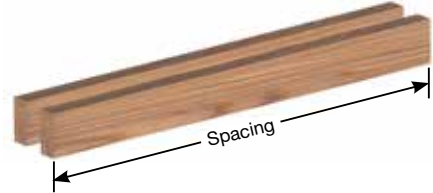

1 - 14

### SIMPLE SPAN 2-DOUBLE WALES

Equivalent Uniform Load (lbs per lineal ft)	SIMPLE SPAN DOUBLE-PLY WALES							
	E = 1,600,000 psi							
	Nominal Size of S4S Lumber							
	2 x 4	2 x 6	2 x 8	2 x 10	2 x 12	3 x 6	4 x 4	4 x 8
	Fb (psi) =							
	1500	1250	1200	1050	975	1250	1500	1200
100	73	108	133	160	185	123	95	165
200	58	91	112	135	156	104	77	139
300	51	80	101	122	141	94	67	125
400	46	73	94	113	131	86	61	117
500	43	66	86	107	124	80	57	110
600	40	61	78	102	118	75	54	105
700	38	56	73	94	110	71	51	101
800	36	52	68	88	103	68	49	98
900	34	49	64	83	97	64	47	95
100	32	47	61	79	92	61	45	93
1100	31	45	58	75	88	58	44	88
1200	30	43	55	72	84	55	43	85
1300	28	41	53	69	81	53	41	81
1400	27	39	51	66	78	51	40	78
1500	26	38	49	64	75	49	39	76
1600	26	37	48	62	73	48	39	73
1700	25	36	46	60	71	46	38	71
1800	24	35	45	58	69	45	37	69
1900	23	34	44	57	67	44	36	67
2000	23	33	43	55	65	43	35	65
2100	22	32	42	54	63	42	34	64
2200	22	31	41	53	62	41	33	62
2300	21	31	40	52	61	40	33	61
2400	21	30	39	51	59	39	32	60
2500	20	29	38	50	58	38	31	59
2600	20	29	37	49	57	37	31	57
2700	20	28	37	48	56	37	30	56
2800	19	28	36	47	55	36	30	55
2900	19	27	35	46	54	35	29	54
3000	19	27	35	45	53	35	29	53

1. All values based on 2005 NDS for S.Y.P. #2  $C_D = 1.45$ ,  $C_{M,b} = 0.85$  (1.0 for 2 x 10 & 2 x 12),  $C_{M,v} = 0.97$ ,  $C_{M,E} = 0.9$
2. Multi-spans continuous over 3 spans or 4 supports.
3.  $\Delta_{max} = \ell/360$ , does not exceed  $1/4"$
4. All values based on worst case of deflection, bending or shear.
5. All values above bold line are controlled by deflection. Bending and shear govern below.

Safe Spacing ( $\ell$ ) in Inches of Supports for  
Double Wales Continuous Over Three or More Spans

$\Delta_{max} = \ell/360$ , but not to exceed  $1/4"$

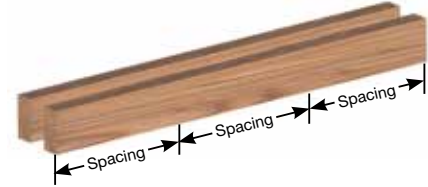

### SIMPLE SPAN 2-DOUBLE WALES

Equivalent Uniform Load (lbs per lineal ft)	SIMPLE SPAN DOUBLE-PLY WALES							
	E = 1,600,000 psi							
	Nominal Size of S4S Lumber							
	2 x 4	2 x 6	2 x 8	2 x 10	2 x 12	3 x 6	4 x 4	4 x 8
	Fb (psi) =							
	1500	1250	1200	1050	975	1250	1500	1200
100	91	127	156	188	217	144	112	193
200	72	107	131	158	183	121	94	163
300	63	96	119	143	165	110	83	147
400	57	83	107	133	154	102	76	137
500	52	74	96	125	145	96	70	129
600	47	68	88	114	133	88	66	123
700	44	63	81	105	123	81	63	119
800	41	59	76	98	115	76	60	115
900	38	55	71	93	109	71	58	109
100	36	52	68	88	103	68	56	104
1100	35	50	65	84	98	65	53	99
1200	33	48	62	80	94	62	51	95
1300	32	46	59	77	90	59	49	91
1400	31	44	57	74	87	57	47	88
1500	30	43	55	72	84	55	45	85
1600	29	41	53	69	81	53	44	82
1700	28	40	52	67	79	52	43	80
1800	27	39	50	65	77	50	41	77
1900	26	38	49	64	75	49	40	75
2000	26	37	48	62	73	48	39	73
2100	25	36	47	61	71	47	38	71
2200	24	35	46	59	69	46	37	70
2300	24	34	45	58	68	45	37	68
2400	23	34	44	57	66	44	36	67
2500	23	33	43	55	65	43	35	65
2600	22	32	42	54	64	42	34	64
2700	22	32	41	53	63	41	34	63
2800	21	31	40	52	61	40	33	62
2900	21	31	40	51	60	40	33	61
3000	20	30	39	51	59	39	32	60

1. All values based on 2005 NDS for S.Y.P. #2  $C_D = 1.45$ ,  $C_{M,b} = 0.85$  (1.0 for 2 x 10 & 2 x 12),  $C_{M,v} = 0.97$ ,  $C_{M,E} = 0.9$
2. Multi-spans continuous over 3 spans or 4 supports.
3.  $\Delta_{max} = \ell/360$ , does not exceed  $1/4"$
4. All values based on worst case of deflection, bending or shear.
5. All values above bold line are controlled by deflection. Bending and shear govern below.

### Meadow Burke Snaptyies

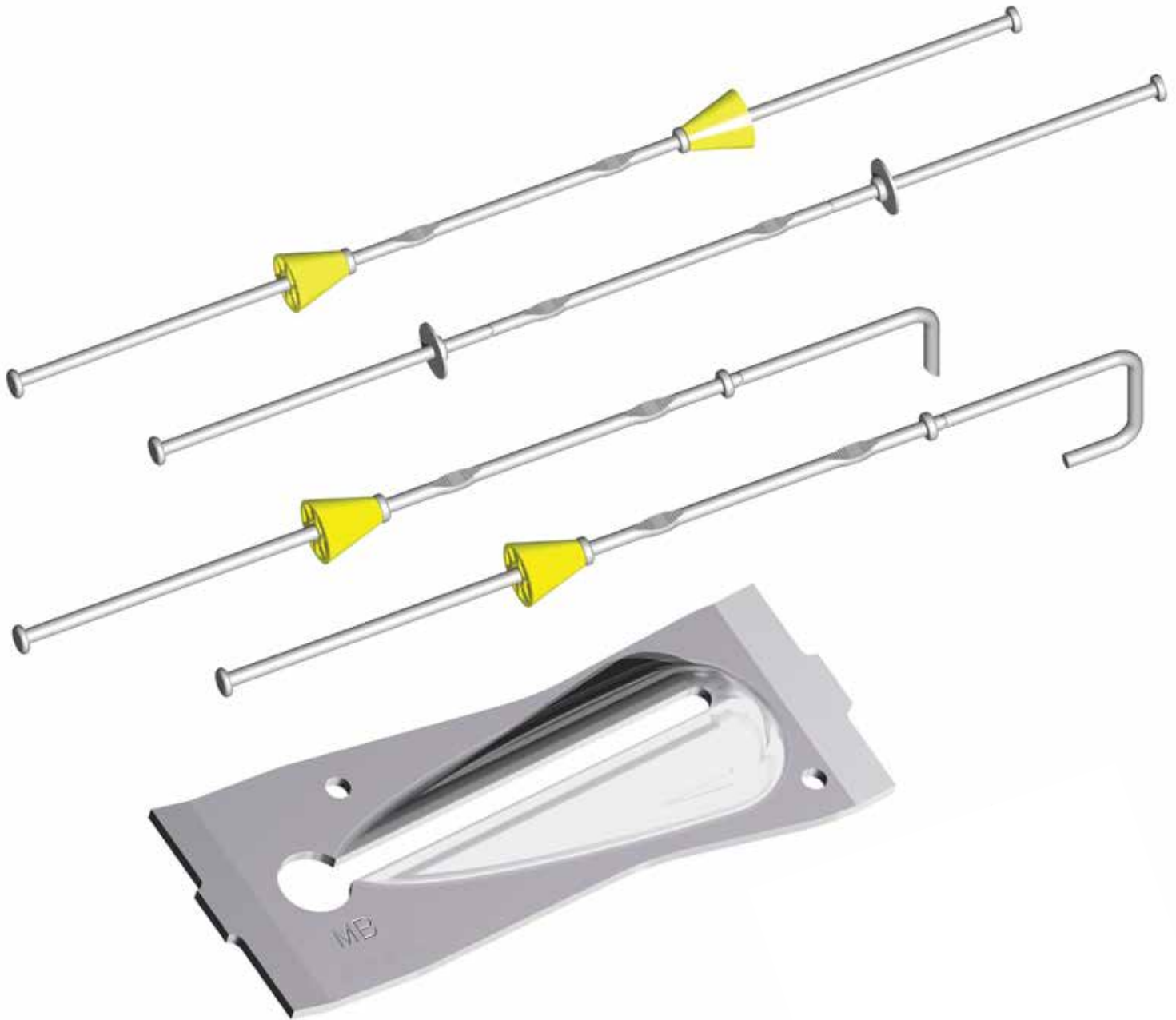

15 - 20

## ST-4 SNAPTIE - STOCK ST-4 SNAPTIE - NON STOCK

The ST-4 Standard Snaptide has anti-turn deformations and 1" breakback. A ½" breakback is available on special order. The Snaptide is available equipped with either plastic spreader cones or loose metal washers.

NOTE: The plastic cones, furnished from high impact polystyrene, are available in the sizes 1x1, 1x1-½ and 1x2. Cones are preferred over a loose washer tie since it covers the break back portion of the tie. Such guarantee of break back is not available with the loose washer tie. When removed the plastic cone also provides a better cavity for grouting purposes. Attempting to breakback any tie, before the concrete has been allowed to properly set, may result in the entire tie turning freely in the wall, making the normal breakback procedure no longer possible. Washer style snaptides should be removed before 24 hours of concrete pour.

*To Order, Specify: quantity, type, L&W, wall thickness, plastic cone or metal washer and breakback*

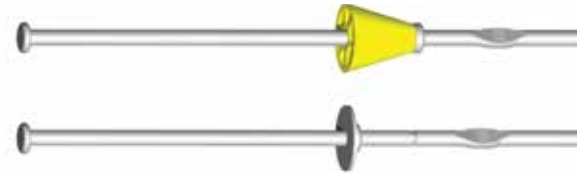

### SAFE WORKING LOAD

TYPE	SWL (lbs)
ST-4	2,250

Safe working load is based on an approximate 2:1 safety factor.

## ST-3 SNAPTIE - HEAVY

The ST-3 Heavy Snaptide incorporates all of the same design features of the standard snaptide but is fabricated from high carbon steel to produce a higher safe working load. It is available with plastic cones or loose metal washers.

*To Order, Specify: quantity, type, L&W, wall thickness, plastic cone or metal washer and breakback*

(L&W = Lumber & Wedge)

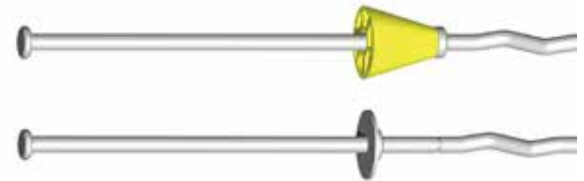

### SAFE WORKING LOAD

TYPE	SWL (lbs)
ST-3	3,250

Safe working load is based on an approximate 2:1 safety factor.

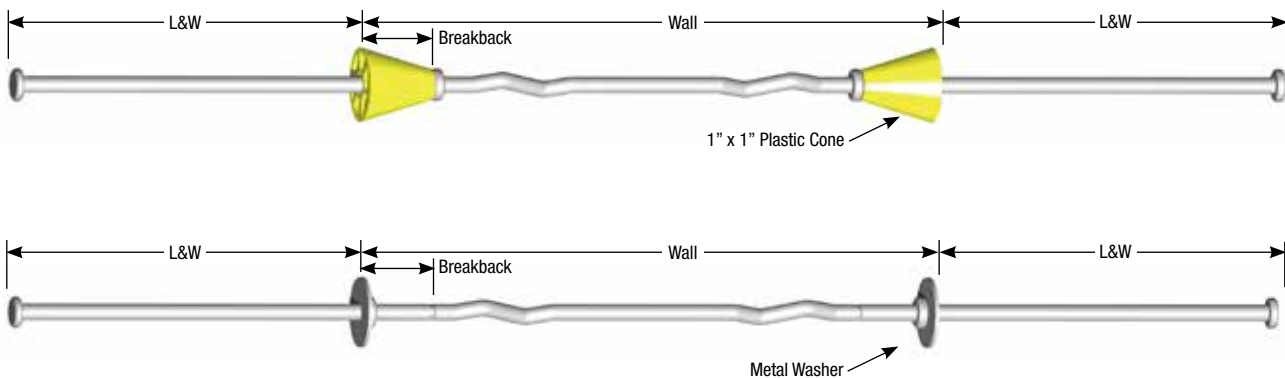

## SNAPTIE DON'TS

- Do not climb on Snapties in the form.
- Do not over-tighten the tie wedges. This can cause severe pre-loading and premature failure.
- Do not place concrete in just one area of the form and allow it to exceed the design pour rate.
- Do not attempt to move the concrete laterally in the form with a vibrator.
- Do not drop the wet concrete more than 30" when placing into the form. This will result in aggregate segregation and unnecessary dangerous impact loading.
- Do not install bent or damaged ties.
- Do not allow Snaptie ends to remain in the wall beyond 24 hours. Remove the breakback portion of the tie as soon as reasonably possible.
- Do not skip or omit any studs or wales. This will likely cause a premature form failure.
- Do not weld Snapties to any object.

## SNAPTIE WATERSEAL

All Meadow Burke Snapties are available with a neoprene washer to aid in preventing moisture seepage along the tie wire. Specify this feature when ordering a snaptie product.



## ST-5 SNAPTIE – THREADED ONE END

The ST-5 Threaded One End Snaptie is manufactured with ¼"-20 threads x 2" length on one end and a standard hot forged head on the opposite end. This tie has a metal washer and is used when walls have a variable thickness. A small channel can be installed on either end and then used as a welding tie.

### SAFE WORKING LOAD

TYPE	SWL (lbs)
ST-5	250

Safe working load is based on an approximate 2:1 safety factor.



## ST-6 SNAPTIE – NAIL POINT

The ST-6 Nail Point Snaptie is designed to have the nail point driven into the formwork and secured with a fence staple. The tie is available with either a plastic spreader cone or a loose metal washer. The plastic cone snaptie is furnished with a standard 1" breakback and the loose metal washer application has a ½" breakback.

### SAFE WORKING LOAD

TYPE	SWL (lbs)
ST-6	250

Safe working load is based on an approximate 2:1 safety factor.

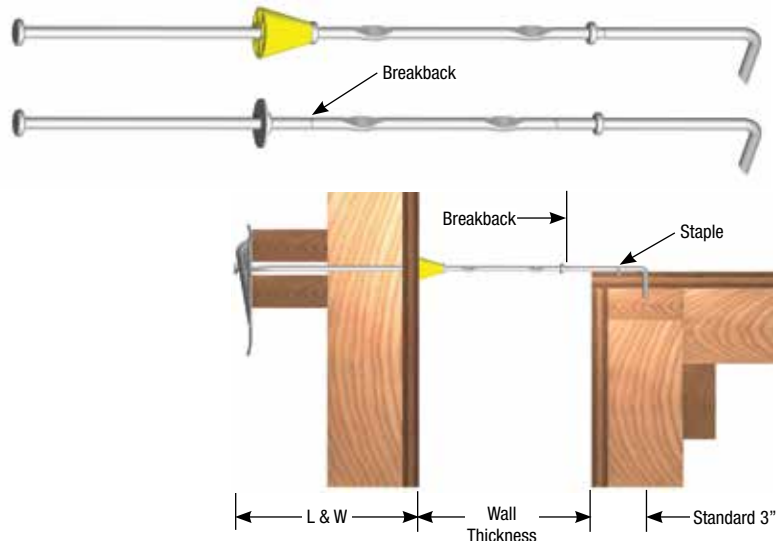

**To Order, Specify: quantity, type, L&W, wall thickness, plastic cone or metal washer.**

## ST-7 SNAPTIE – HOOKED

The ST-7 Hooked Snaptie is designed to attach formwork to a structural beam. The hook end of the tie fits over the flange of the beam and should be tack-welded on the underside of the beam flange for added security. Hooked snapties are available with plastic cone or loose metal washer.

### SAFE WORKING LOAD

TYPE	SWL (lbs)
ST-16	250

Safe working load is based on an approximate 2:1 safety factor.

*To Order, Specify: quantity, type, plastic cone or metal washer, length, flange thickness and form thickness L&W.*

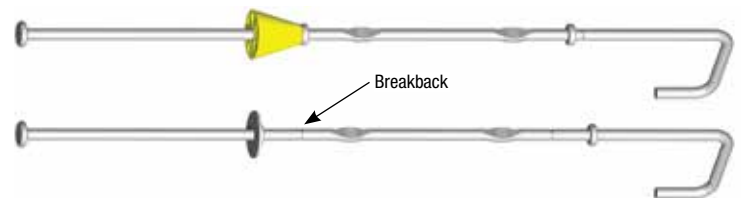
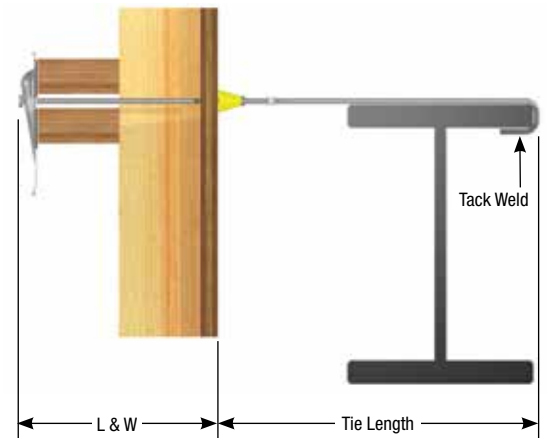

## ST-15 STEEL WEDGE

The ST-15 Steel Wedge accommodates either standard or heavy snapties and is designed with sufficient strength to distribute the form loads to the wales.

### SAFE WORKING LOAD

TYPE	SWL (lbs)
ST-9	250

Safe working load is based on an approximate 2:1 safety factor.

*To Order, Specify: quantity and type.*

Caution: The safe working load of the Steel Wedge can be affected by the position of the wedge on the tie end. Reference Steel Wedge Assembly Precautions that follow.



## STW-15 STACKING TIE WEDGE

The STW-15 Stacking Tie Wedge accommodates either standard or heavy snapties and is designed with sufficient strength to distribute the form loads to the wales.

### SAFE WORKING LOAD

TYPE	SWL (lbs)
ST-15	750

Safe working load is based on an approximate 2:1 safety factor.

*To Order, Specify: quantity and type.*

Caution: The safe working load of the Steel Wedge can be affected by the position of the wedge on the tie end. Reference Steel Wedge Assembly Precautions below.

### WEDGE ASSEMBLY PRECAUTIONS:

Excessive spacing between the walers may cause the steel wedge to bend and result in the cone or washer on the snaptie to become embedded in the concrete. Breakback of the snaptie would be made difficult to accomplish.

Over-tightening the wedge may damage the head of the snaptie, the wedge slot and/or the plastic cone and result in a premature failure.

The Steel Wedge is designed to carry the load at the upper  $\frac{2}{3}$  of the wedge slot. Load applied too low on the wedge slot may cause the wedge to deform or break.

Nail holes are provided to allow the wedge to be firmly secured to the wales to prevent loosening during vibration.

## ST-21 SNAPTIE WRENCH

The ST-21 Snaptie Wrench is used to quickly and easily breakback snapties. After the forming has been stripped the Snaptie Wrench captures the snaptie end. The tie is bent down to a position nearly parallel to the face of the concrete and a subsequent clockwise rotation of the wrench breaks the tie at the breakback point.

*To Order, Specify: quantity and type.*

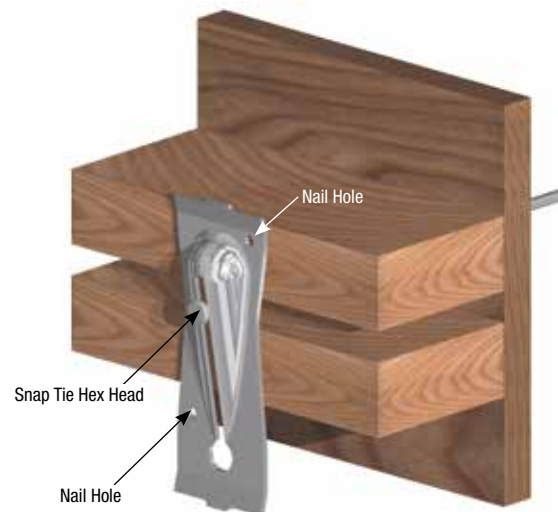
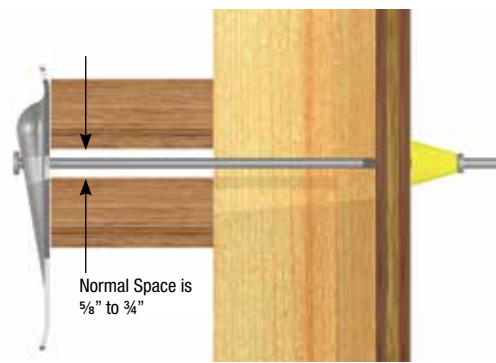

## ST-18 RESIDENTIAL SNAPTIE – METAL WASHERS

The ST-18 Residential Snapties are designed to be used on stem-type footing walls, foundation walls, and basement walls.

The ST-18 Residential Snapties are available with fixed 1-¼” washers for a flush breakback. This breakback routinely results in the wire being flush with the surface of the concrete or slightly protruding outside the surface. When a finished wall is desired, this tie is also available with a 1” cone and a 1” breakback.

With an end dimension of 1-5/8”, the Meadow Burke Residential Snapties can be used with ST-15 Steel Wedges. Frequently used with our Quick Cleat (see page 32).

### SAFE WORKING LOAD

TYPE	SWL (lbs)
ST-18	2,250

Safe working load is based on an approximate 2:1 safety factor.

*To Order, Specify: quantity, type, L&W, wall thickness, plastic cones or metal washer and breakback.*

ST-18



### Single Waler System



## SINGLE WALER SYSTEM

The Meadow Burke Single Waler System is an economical, modern wall forming method designed for use on straight, battered, curved and rounded walls and with various beam forms.

Whether your forming needs are for a four-foot knee wall or a twelve-foot retaining wall, the Single Waler System can accommodate all of your handset light forming requirements.

The complete System includes:

- Plastic cone or loose metal washer snapties with 4- $\frac{3}{4}$ " ends
- Single Waler Bracket
- Form Aligner Clamp for strongbacks
- Snap Jack for walls over 8' high
- Form Aligner

See Page 25 for typical installation sequence.



## ST-12 "A" BRACKET

The ST-12 "A" bracket is a key element in the Single Waler System. It is fabricated for high strength steel and cadmium plated eccentric and a rust resistant painted body for high corrosion resistance. Designed for use with a 2x4 waler, the bracket is used to hold either a single horizontal wale, or a single vertical stud. The bracket can be installed either before or after the walers are in place. Slots in the bracket allow it to slip over the snaptie end. Loading from the bracket is against the 2x4 instead of the plywood. The "A" bracket uses 4  $\frac{3}{4}$ " L&W standard snapties.

*To Order, Specify: quantity and type.*

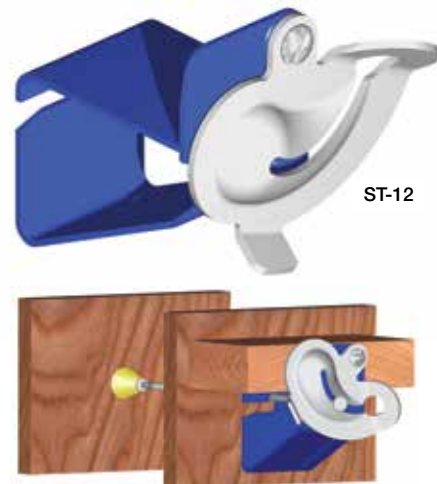

## ST-11 FORM ALIGNER CLAMP

The ST-11 Form Aligner Clamp provides the Single Waler System with a fast and easy way to attach 2x4 strongbacks to the form. The galvanized clamp can be installed vertically or horizontally at any point on the form.

*To Order, Specify: quantity and type.*



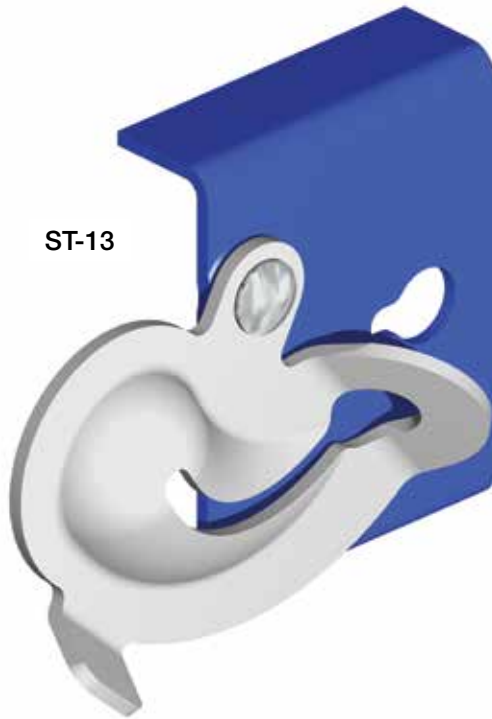

21 - 28

## ST-13 "C" BRACKET

The ST-13 (Jahn) "C" Bracket by Meadow Burke is used to attach single 2x4 studs and double vertical strongbacks for formwork alignment. Also engineered for use with double wales to support a horizontal plywood joint. Uses 8-1/4" L&W standard snapties.

*To Order, Specify: quantity and type.*

## WALER SPACING AND TIE ALIGNMENT

Misalignment of walers can cause Snapties to bend. Bent Snapties will not carry the expected design loads and a premature failure may result.

Wales must be continuous with joints staggered. Do not omit any walers. Omitting one of a double waler set will cause load redistribution and can result in a tie failure. All walers must be in place and all ties must be positioned properly.

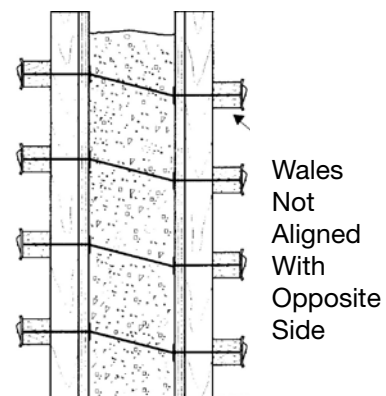

## ST-27 FORM ALIGNER

## ST-28 FORM ALIGNER

The ST-27 & ST-28 Form Aligner are designed to align vertical formwork. The ST-27 Standard brace consists of a length of angle iron, a self-cleaning turnbuckle and a steel toe plate. The angle iron is equipped with nail holes allowing the Form Aligner to be attached to a 2x4 or 2x6 to extend the reach of the ST-27. The turnbuckle is fabricated with coil threads for quick and easy adjustments and the steel toe plate can accept a round steel stake, be nailed to a wood stake or be inverted and nailed directly to a stud or wales. The ST-28 Form Aligner is equipped with a spade-type toe plate designed for use with modular forms and wedge bolts.

The safe working load for the Form Aligner is determined by the method of attachment and the extension lumber used.

*To Order, Specify: quantity and type.*



## SINGLE WALER FORMING APPLICATION

### Gang Drilling Plywood

Gang drilling is a quick and economical way to prepare plywood for the single waler forming application. Simply stack the plywood and drill the tie holes with a 5/8" drill bit. The System works equally well with 5/8" or 3/4" plywood. The wedge take-up in the bracket will compensate for the difference in plywood thickness.

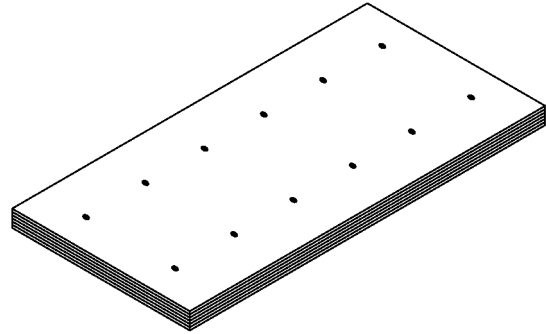

### Common Spacing Layouts

Maximum allowed form pressure is 4'-0" per hour at 70° F. Recommended 9/16" drill bit for form hole. Plywood thickness for this diagram is 3/4". Standard waler spacing is 16".

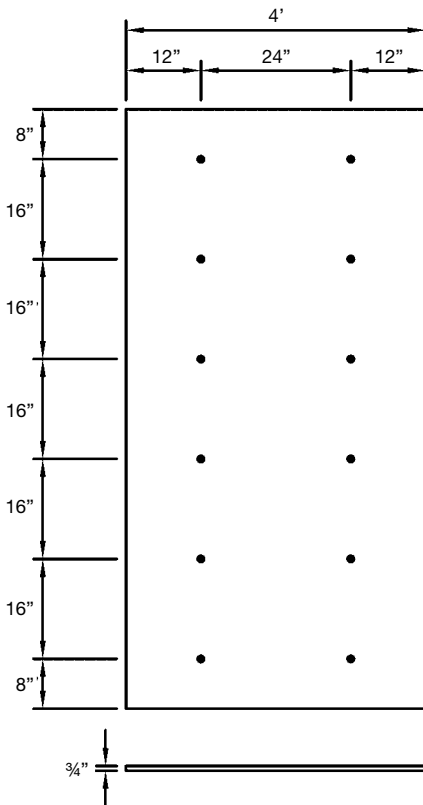

**12 Holes**

You can minimize the amount of ties required with this standard spacing layout. You can also eliminate the need of a starter plate on 8' walls.

**Note:** For 1/360 deflection, use 12" waler spacing.

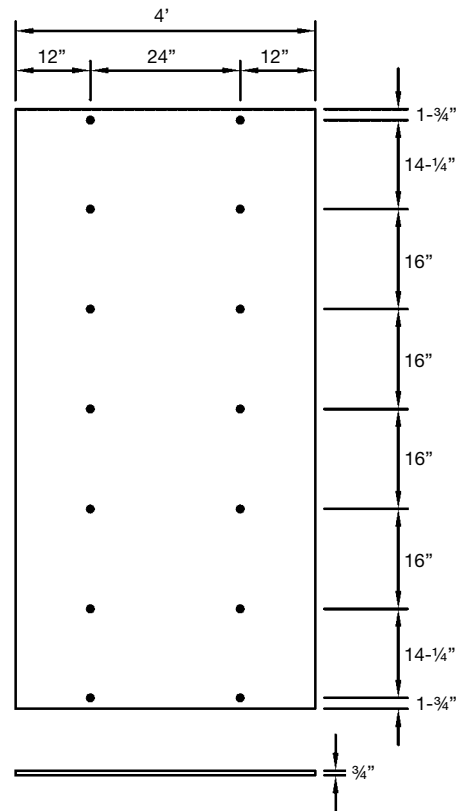

**14 Holes**

This pattern is required for walls over 8' or when panels are to be attached to a kicker plate with inverted brackets. With this panel layout, the top waler is used to start the next tier of panels.

## SINGLE WALER BRACKET INSTALLATION

### Wall Height Considerations

Snaptie spacing is dependent upon form pressure and the type of forming used. Below are a few typical wall form spacing diagrams for various wall heights with pertinent notes for each height.

#### Wall Form 4 ft. High

- Install 4'x8' plywood horizontally. Attach 2x4 walers with horizontal tie-spacing of 2'-0" on center.

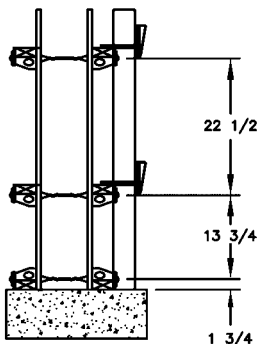

#### Wall Form 8 ft. High

- Attach strongbacks vertically to full height of form.
- Use proper spacing to engage next row of ties, while attaching waler with form aligner clamps.
- Easily attach plywood and secure with wrench head snapties and single waler forming brackets.

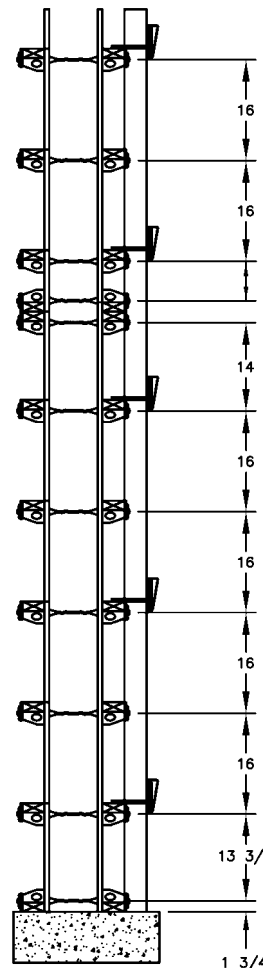
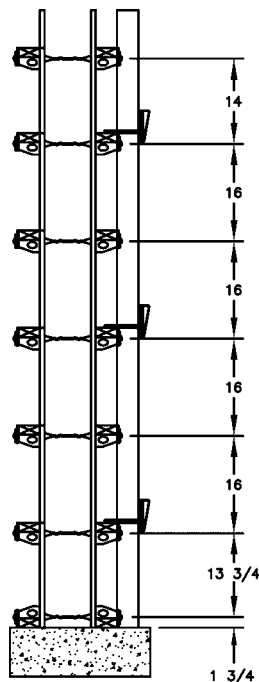

#### Wall Form Over 8 ft. High

- Single or Double 2x4 strongbacks with support clamps fastened to every other waler provides a stable alignment for walls over 10 ft.
- Nail a waler to top of last waler at plywood joint.
- Nail aligner brace to vertical strongback at 1/3 height from top of form.
- Only one side needed for bracing.
- Form aligner brace spacing at 6 ft. on center.

## SINGLE WALER BRACKET INSTALLATION

### Typical Installation Sequence



1: Stack standard 3/4" or 5/8" plywood sheets. Drill with 9/16" drill bit.

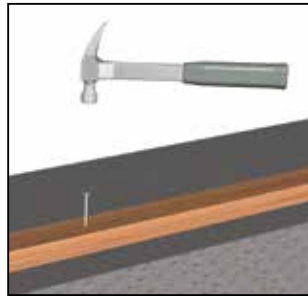

2: Nail 2x4 kicker plates to concrete footing with concrete nails.

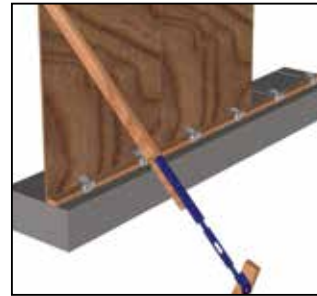

3: Nail vertical plywood panels to 2x4 kicker plate. (Or attach to inverted single waler brackets on kicker plate - support panels temporarily, as needed.)



4: Place Snapties through pre-drilled panels from inside of form.

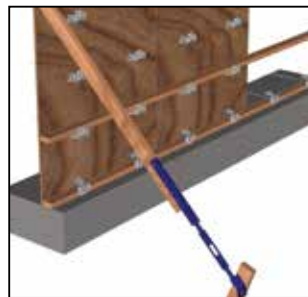

5: Attach Single Waler Brackets on snapties. Do not need to tighten an entire row before installing 2x4 waler. Repeat process for following rows.



6: Tap Single Walers with hammer to tighten. Place 2x4 strongbacks (if desired) and secure with Form Aligner Clamps.

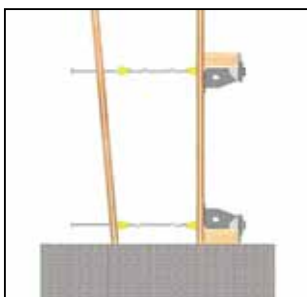

7: Install panels over snapties on opposite side and repeat steps 5 and 6 .

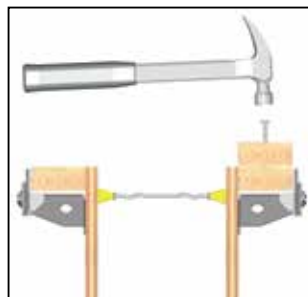

8: (OPTIONAL) For wall over 8 ft. high. Nail a 2x4 on top of last waler to act as kicker plate.

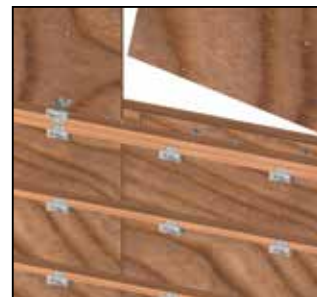

9: Following step 8, align above plywood panels against new top kicker plate and repeat steps 3 through 7. (Scaffolding required) See Snap Jack instructions.

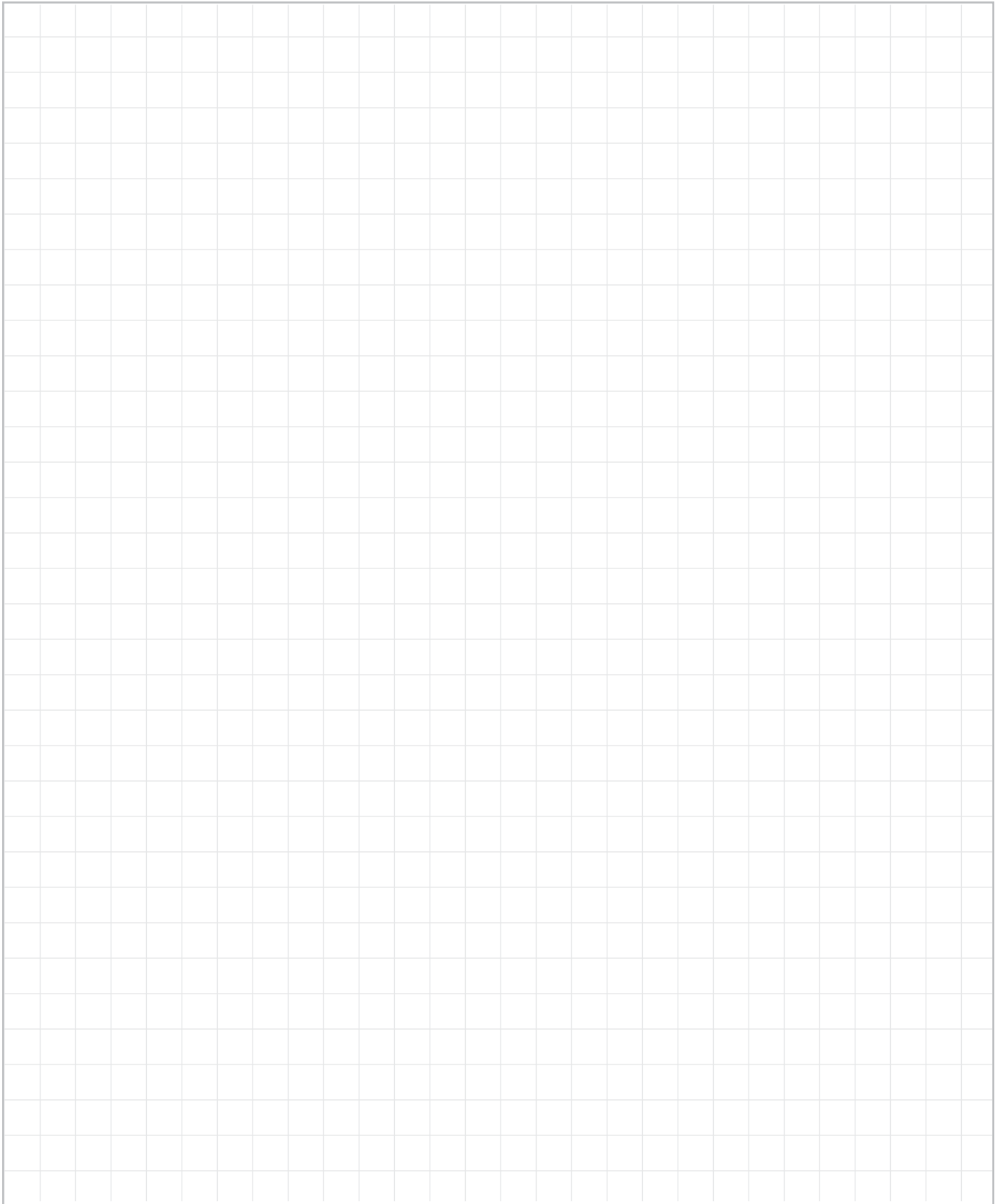

Light, Medium and Heavy Forming Products



## ST-19 PANEL LOCK TIE

The ST-19 Panel Lock Tie is used in conjunction with a Steel Wedge to quickly and securely lock adjacent form panel 2x4 studs together. The standard length is 3-½" with other lengths available on special order.

*To Order, Specify: quantity, type and length.*



## RD-24 PENCIL ROD

The RD-24 Mild steel Pencil Rod is available in ¼" diameter in coils of approximately 600 feet (100 lbs.).

*To Order, Specify: quantity, type and diameter.*

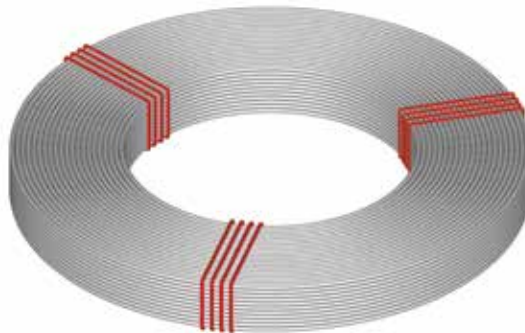

**RD-25 PENCIL ROD TIGHTENER**

The RD-25 Pencil Rod Tightener is used in conjunction with the pencil rod/form clamp assembly to draw the formwork into position and hold it securely while the rod clamp set screw is tightened. The Tightener is available in ¼" diameter.

*To Order, Specify: quantity and type.*

**RD-27 PLASTIC TUBING**

The RD-27 Plastic Tubing is available for use when pencil rod must be removed from set concrete. The tubing is cut to size and slipped over the pencil rod to act as a sleeve to aid in the rod removal process. Plastic Tubing is stocked in ¼" diameter in 5' lengths.

*To Order, Specify: quantity and type.*



## CT-1 COIL TIE – WELDING

The versatile and economical two strut CT-1 Coil Tie is available with one end open to allow the struts to be field welded when unusual forming situations are encountered. The Welding Coil Tie is available in ½", ¾" and 1" diameters and in overall lengths as required.

CT-1 COIL TIE DATA					
Coil Boly Diameter	Tie SWL (lbs)	Strut Wires		Field Weld Lgth (min)	Open End Diameter
		Dia.	AISI No.		
½"	6,750	.306	1008	1"	¾"
¾"	9,000	.375	1018	1-½"	1"
1"	15,000	.440	1035	2"	1-¾"

Safe working load is based on an approximate 2:1 safety factor.

Actual safe working load of the Welding Coil Tie is dependent on the quality of the field weld. See AWS D1.4 for welding specifications.

*To Order, Specify: quantity, type, diameter and length.*

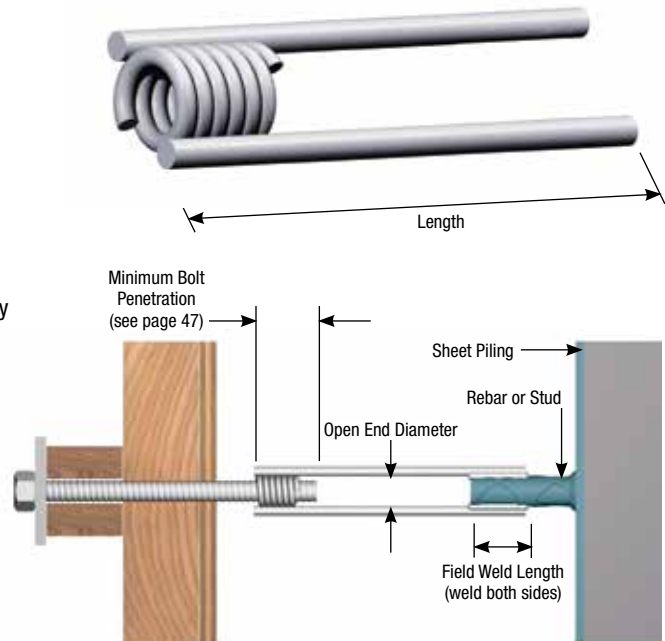

## CT-2 COIL TIE – TWO STRUT

The CT-2 Coil Tie is fabricated with two struts and two self-cleaning, fast threading coils and is available in a broad range of sizes and safe working loads. The versatile tie is used with Coil Bolts or Coil Rod to handle the many forming variations encountered. The Two Strut Coil Tie is available in ½" to 1" diameters in standard and heavy types.

CT-2 COIL TIE DATA		
Numbers	Type	Wire Size
½" Standard	4,500	9,000
½" Heavy	6,750	13,500
¾" Standard	6,750	13,500
¾" Heavy	9,000	18,000
1" Standard	13,500	27,000
1" Heavy	15,000	30,000

SWL provides an approximate safety factor of 2:1.

NOTE: If electro-plating of coil ties is required, special procedures may be necessary to prevent hydrogen embrittlement effects. Specify when placing order.

*To Order, Specify: quantity, type, diameter and length (wall thickness).*

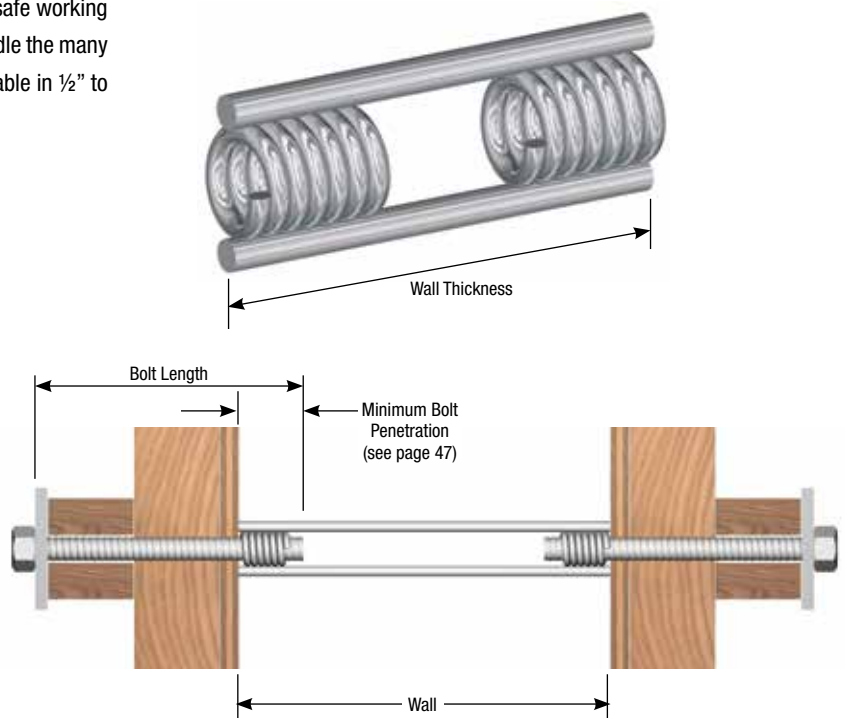

## CT-4 COIL TIE – FOUR STRUT

The CT-4 Coil Tie - Four Strut is similar in form and use to the Coil Tie - Two Strut, but has two additional struts to develop higher load capacities. Coil Tie - Four Strut is available in 1" diameter standard, 1-¼" standard and 1-¼" heavy configurations.

CT-2 COIL TIE DATA		
Type	SWL (lbs)	APROX ULT (lbs)
1" Standard	18,000	36,000
1-¼" Standard	27,000	54,000
1-¼" Heavy	30,000	60,000

*To Order, Specify: quantity, type, diameter, standard or heavy and length (wall thickness).*

Safe working load is based on an approximate 2:1 safety factor.

**NOTE:** If electro-plating of coil ties is required, special procedures may be necessary to prevent hydrogen embrittlement effects. Specify when placing order.

**CAUTION:** When pouring walls over 8' high, consider using the next higher load rated coil tie for additional safety factor. Form pressures tend to be greater than expected or planned when pouring higher walls. See Page 4 for additional safety information.

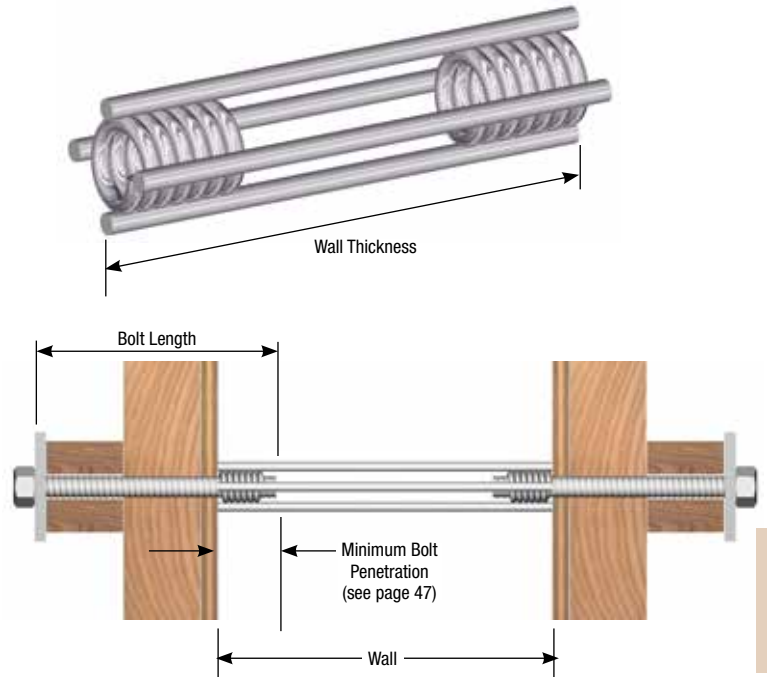

## CT-2/CT-4 COIL TIES - CONE FAST

The CT-2/CT-4 Coil Ties - Cone Fast are fabricated with longer coils that extend beyond the ends of the struts to allow threaded plastic cones to be attached to the Coil Tie. The cones provide a spreader function for the tie as well as a specific setback. They also act as a centering guide when attaching the coil bolts during setup.

Cone-Fast Coil Tie recesses left by the plastic cones provide an architectural effect on the face of the concrete and the setback places the tie back away from the concrete surface to reduce surface corrosion staining.

Two strut CT-2 Coil Tie - Cone Fast is available in ½", ¾", and 1" standard and heavy types. The four strut CT-4 Coil Tie - Cone Fast version is available in 1" and 1-¼" standard and 1-¼" heavy.

Safe working loads of the Coil Tie - Cone-Fast are the same as the comparable Two Strut and Four Strut Coil Ties. For additional safety information, refer to page 4.

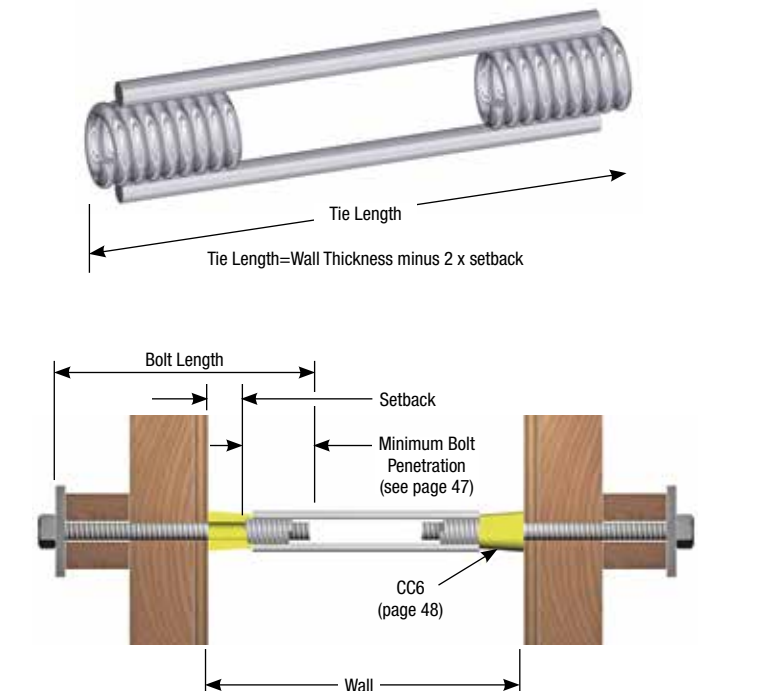

*To Order, Specify: quantity, type, diameter, standard or heavy, tie length, wall thickness and setback.*

**NOTE:** To determine length, subtract two times the setback from the wall thickness.

## COIL TIE – WATER SEAL

All two-strut and four-strut Coil Ties are available with a neoprene rubber washer installed on each wire strut. The neoprene washers help prevent the seepage of water along the wire struts. In damp or wet conditions this is a beneficial addition to the form tie system.

*To Order, Specify: Water Seal Washers when ordering the Coil Ties.*



## HD-40 HE BOLT

The HD-40 He Bolt is fabricated similar to the She Bolt but has external coil threads at both ends. It is used primarily in conjunction with a previously cast in place form anchor to reanchor cantilever forms. He Bolts are available in two sizes, 1-1/4" x 1" and 1-1/2" x 1-1/4" and are furnished with a square wrench end to aid in the removal process. They will accommodate pour rates up to 10' and are reusable, subject to thread wear.

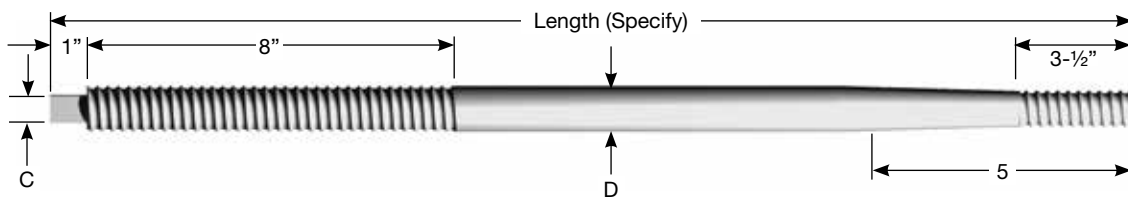

HD-40 HE BOLT DATA				
Large Diameter	Small Diameter	"C" Dimension	Tension Safe Work Load (lbs)	Shear Safe Work Load (lbs)
1-1/4"	1"	3/4"	34,000	22,500
1-1/2"	1-1/4"	1"	50,000	33,500

Safe working load is based on an approximate 2:1 safety factor.

**NOTE:** If setting-pin hole is required, it must be specified when ordering.

*To Order, Specify: quantity, type, diameter and length.*

## TYPICAL CANTILEVER FORM UTILIZING THE HE BOLT SYSTEM

Several coil loop anchors are available for use with the He Bolt. Meadow Burke recommends using only four-strut anchors for reanchoring to previous pours when lifts over five (5) feet are encountered. See pages 52 & 55 for additional detail.

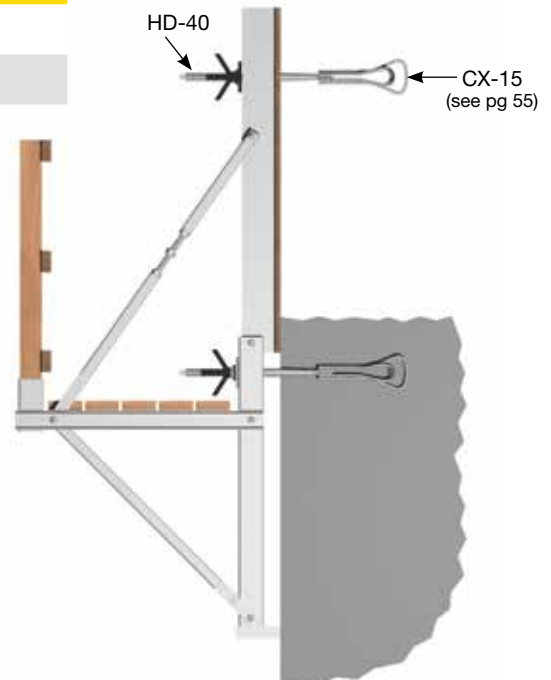

Coil Form Tie Accessories and Working Parts



## CN-5 COIL NUT – STANDARD

The CN-5 Standard Coil Nut is manufactured from hex stock and is available in 1/2" through 1-1/2" diameters. Dimensions are displayed in the Table.

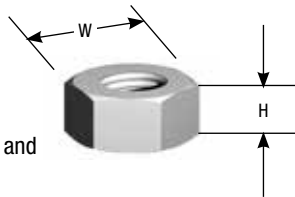

Available supplied in plain finish and electroplated galvanized

CN-5 COIL NUT - STANDARD DATA			
Diameter	Flat Width (W)	Height (H)	Safe Work Load (lbs)
1/2"	7/8"	1/2"	6,000
3/4"	1-1/8"	5/8"	12,000
3/4"	1-1/4"	3/4"	12,000
1"	1-5/8"	1"	18,000
1-1/4"	2"	1-1/4"	27,000
1-1/2"	2-3/8"	1-1/2"	40,000

Safe working load is based on an approximate 2:1 safety factor.

**Note:** In order to achieve the published safe working loads of Coil Bolts, Coil Rods, etc. when using the Standard Coil Nut; two (2) Standard Coil Nuts tightly locked together are required.

*To Order, Specify: quantity, type and diameter.*

## CN-25 COIL NUT – HEAVY

The CN-25 Heavy Coil Nuts are manufactured from hex stock like the Standard Coil Nut but is of sufficient length to develop the safe working loads required for medium and heavy form tying systems.

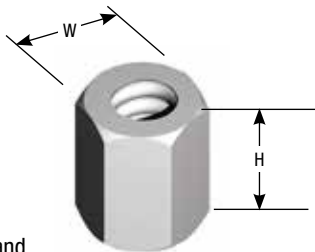

Available supplied in plain finish and electroplated galvanized

CN-25 COIL NUT - HEAVY DATA			
Diameter	Flat Width (W)	Height (H)	Safe Work Load (lbs)
1/2"	7/8"	1"	9,000
3/4"	1-1/8"	1-1/2"	18,000
1"	1-5/8"	2"	38,000
1-1/4"	2"	2-1/2"	56,000
1-1/2"	2-3/8"	3"	68,000

Safe working load is based on an approximate 2:1 safety factor.

*To Order, Specify: quantity, type and diameter.*

## CN-27 HANDLE COIL NUT

The CN-27 Handle Coil Nut is fabricated by welding a substantial wire loop to a Standard Coil Nut. The unit is designed to provide quick tightening and release functions without the need of a wrench.

*To Order, Specify: quantity, type and diameter.*

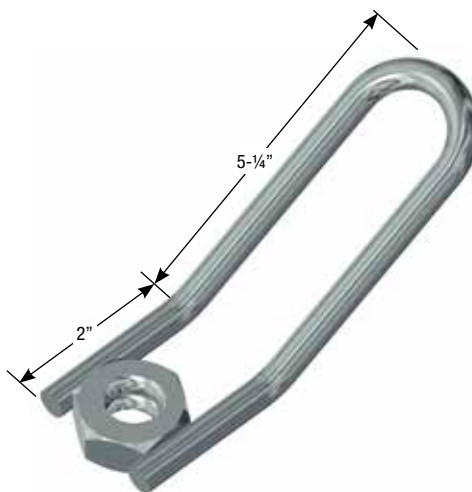

CN-27 HANDLE COIL NUT DATA	
Coil Rod Diameter	Safe Work Load (lbs)
1/2"	4,500
3/4"	9,000
1"	18,000
1-1/4"	27,000

Safe working load is based on an approximate 2:1 safety factor.

## CN-29 COIL WING NUT

The CN-29 Coil Wing Nuts are furnished with coil thread and are available in 1/2" through 1-1/2" diameters. The ductile iron Coil Wing Nut offers high strength, speedy tightening and release.

CN-29 COIL WING NUT DATA					
Diameter	L	D	H	W	Safe Work Load (lbs)
1/2"	5"	1-1/4"	2-3/8"	1-3/8"	9,000
3/4"	5-7/8"	1-1/4"	2-1/2"	1-3/4"	18,000
7/8"	6"	1-5/8"	2-3/4"	1-3/4"	18,000
1"	6"	1-5/8"	3"	2"	38,000
1-1/4"	6-5/8"	1-5/8"	2-3/4"	2-1/4"	52,000
1-1/2"	6-3/4"	1-7/8"	2-3/4"	2-7/8"	80,000

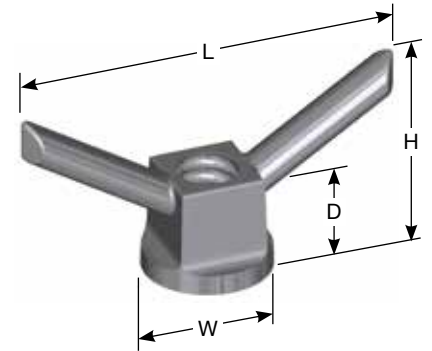

Safe working load is based on an approximate 2:1 safety factor.

*To Order, Specify: quantity, type and diameter.*

## CW-4 FLAT WASHER

The CW-4 Flat Washers are manufactured from high carbon flat steel plate and are designed to provide the required bearing against the form members. Flat Washers are available in many sizes in both standard and heavy versions. Refer to the Table for dimensions.

CW-4 FLAT WASHER DATA			
Standard Washer		Heavy Washer	
Bolt Dia.	Size	Bolt Dia.	Size
1/2"	1/4 X 3 X 4	1/2"	1/4 x 4 x 5
3/4"	1/4 x 4 x 5	3/4"	1/2 x 5 x 5
1"	1/2 x 5 x 5	--	--
1-1/4"	1/2 x 5 x 5	1-1/4"	3/4 x 7 x 7



*To Order, Specify: quantity, type and diameter.*

### CB-2 COIL BOLT

The CB-2 Coil Bolts are available in ½” through 1-½” diameters for use with Coil Ties, Coil Inserts and other Meadow Burke products furnished with coil threads. Coil Bolts are manufactured with the fast-threading, self-cleaning coil thread and are available in lengths as needed.

Coil Bolts may be furnished with an integral forged head or with a hex nut welded to a length of continuous coil rod. Standard thread length of the integral forged head Coil Bolt is 4” on the ½” diameter and 4-½” on all other sizes. For minimum coil penetration, see page 45.

*To Order, Specify: quantity, type and diameter.*

Use of waterproof, stain resistant grease applied to the bolt shaft will aid in the bolt removal process. Note that Coil Bolts are subject to wear and misuse and should be continually inspected for wear, cracks, bends, overstressing, etc. If there is any indication of these types of problems, the bolt should be discarded.

### CB-4 ADJUSTABLE COIL BOLT

The CB-4 Adjustable Coil Bolt consists of a length of Coil Rod with a Coil Nut welded on one end and a free running Coil Nut on the threaded section. This unit simplifies ordering on projects where unusual forming conditions require numerous bolt lengths. The Adjustable Coil Bolt is available in 1/2” and 3/4” diameters in standard 18” and 24” lengths. Other diameters and lengths are available on special order. For minimum coil penetration, see page 47.

*To Order, Specify: quantity, type and diameter.*

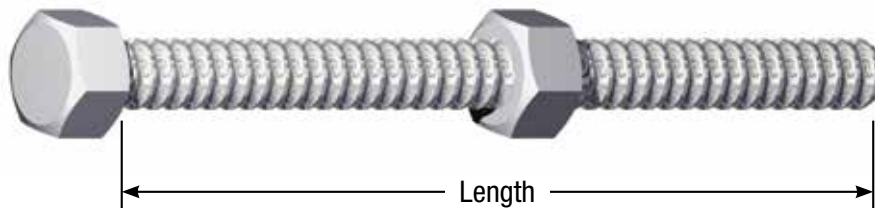

## COIL BOLT (CONT.)

### MINIMUM COIL PENETRATION

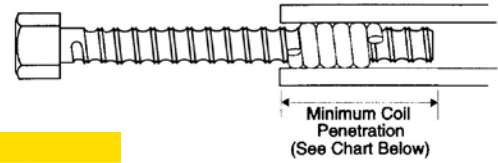

CB-2 & CB-4 COIL BOLT PENETRATION DATA									
½" Diameter Over 6"		¾" Diameter		1" Diameter		1-¼" Diameter		1-½" Diameter	
Tension	Shear	Tension	Shear	Tension	Shear	Tension	Shear	Tension	Shear
9,000	6,000	18,000	12,000	38,000	25,000	56,000	40,000	68,000	45,000
Minimum Coil Penetration 2"		Minimum Coil Penetration 2-½"		Minimum Coil Penetration 2-½"		Minimum Coil Penetration 3"		Minimum Coil Penetration 3"	
Treads per inch 6		Treads per inch 4-½		Treads per inch 3-½		Treads per inch 3-½		Treads per inch 3-½	
Min. Root Area Square Inches .1385		Min. Root Area Square Inches .3080		Min. Root Area Square Inches .5410		Min. Root Area Square Inches .9160		Min. Root Area Square Inches 1.3890	

Safe working load is based on an approximate 2:1 safety factor.

**WARNING:** Minimum coil penetration is extremely important and must be adhered to when threading Coil Bolts into other coil-threaded products. Safe working loads are dependent on maintaining the appropriate minimum coil penetration; failure to do so can lead to a premature failure of the coil and compromise worker safety. Refer to the Table for safe working loads and minimum coil penetration lengths.

### CR-4 COIL ROD – HI-STRENGTH

The CR-4 Coil Rods are manufactured from quality high-grade steel with a full-length coil thread. It is available in ½" to 1-½" diameters cut to length or in 10' or 12' lengths for field cutting. CR-4 Hi-Strength Coil Rod is furnished in 12' lengths. Longer lengths are available on special order. Coil Rod can be used with numerous other coil-threaded products to fashion an adjustable tie, an emergency tie, embedded as an adjustable anchorage, etc.

**Note:** ½" and ⅝" dia. is available only as CR-4 Hi-Strength Coil Rod. Coil Rod requires two Standard Coil Nuts or one Heavy Coil Nut to develop the safe working loads shown. Minimum coil penetration applies; see coil penetration warning above.

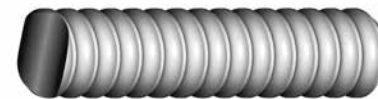

CR-4 COIL ROD DATA		
Coil Rod Diameter	CR-4 Safe Work Loads (lbs)	Threads per Inch
½"	9,000	6
¾"	18,000	4.5
1"	38,000	3.5
1 ¼"	56,000	3.5
1 ½"	68,000	3.5

Safe working load is based on an approximate 2:1 safety factor.

*To Order, Specify: quantity, type, bolt diameter and length.*

## CC-6 CONE-FAST CONES

The CC-6 Cone-Fast Cones are designed with internal coil threads to engage the protruding coils of the Cone-Fast Coil Tie and provide a positive form spreader action.

Cone-Fast Cones are stocked in all Cone-Fast Coil Tie diameters. Reference the Table for cone dimensions and setback.

*To Order, Specify: quantity, type, bolt diameter and setback.*

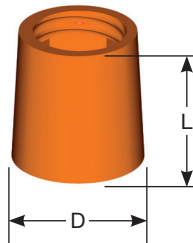

CC-6 CONE-FAST CONES DATA			
Bolt Diameter	Setback	L	D
1/2"	1"	1-3/8"	1-1/4"
1/2"	1-1/2"	1-7/8"	1-1/4"
1/2"	2"	2-3/8"	1-1/4"
3/4"	1-1/2"	2-1/2"	1-3/4"
3/4"	2"	2-1/2"	1-3/4"
1"	2"	2-1/2"	2-1/8"
1-1/4"	2"	2-1/2"	2-3/8"

## CW-7 CONE WRENCH

The CW-7 Cone Wrench is available in sizes corresponding to the Cone-Fast Cones (above) to facilitate the removal of the cones from the concrete.

*To Order, Specify: quantity, type and bolt diameter.*

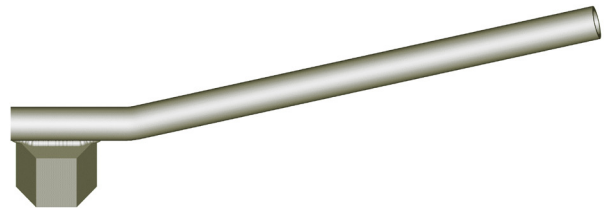

## HD-32 STOP COUPLER

The HD-32 Stop Coupler has coil threads tapped from each end creating a stop in the middle. Coil Rods or Inside Rods must be threaded to the internal stop in order to achieve the listed safe working loads.

HD-32 STOP COUPLER DATA			
Thread Diameter	D	L	Safe Work Load (lbs)
1/2"	3/4"	2-1/2"	9,000
3/4"	1-1/16"	3"	18,000
1"	1-1/2"	4-1/2"	38,000

Safe working load is based on an approximate 2:1 safety factor.

*To Order, Specify: quantity, type and thread diameter.*

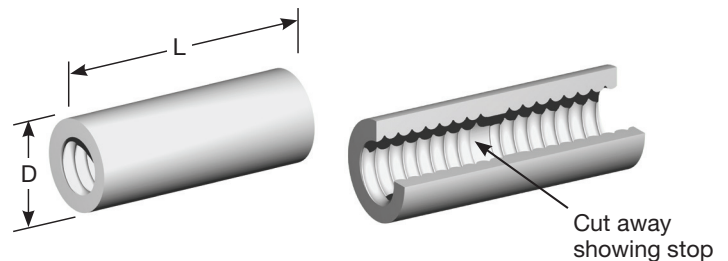

## CT-4 COIL ROD COUPLER

The CT-4 Coil Rod Coupler is a special four or six strut coil tie used in conjunction with Coil Rod to satisfy unusual forming conditions or variations. It is available in 1/2", 3/4" and 1" diameters in the lengths shown in the Table.

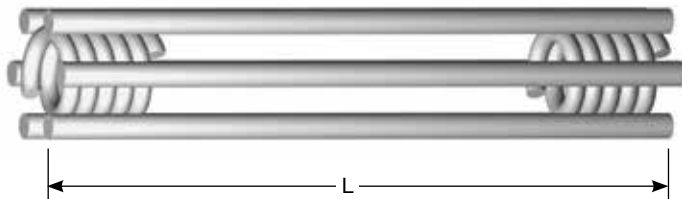

CT-4 COIL ROD COUPLER DATA			
Diameter	Struts	Length (L)	Safe Work Load (lbs)
1/2"	4	8"	9,000
3/4"	4	8"	18,000
1"	6	10"	38,000

Safe working load is based on an approximate 2:1 safety factor.

*To Order, Specify: quantity, type, diameter, and length.*

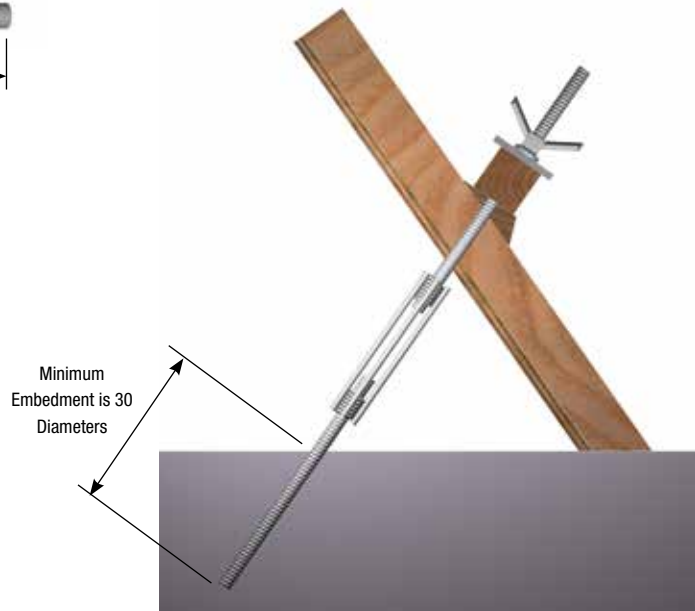

## CT-20 PLYLAG

The CT-20 Plylag is designed to firmly attach wales and/or strongbacks to modular forms or to provide an attachment method for coil threaded products. The Plylag is available in 1/2" diameter.

The Plylag is available in 1/2" diameter.

CT-20 PLYLAG DATA			
Diameter	Length (L)	B	Safe Work Load (lbs)
1/2"	6-1/4"	3-1/2"	3,000
1/2"	6-3/4"	4"	3,000
1/2"	9-3/4"	7"	3,000
1/2"	14-3/4"	12"	3,000

Safe working load is based on an approximate 2:1 safety factor.

*To Order, Specify: quantity, type and length.*

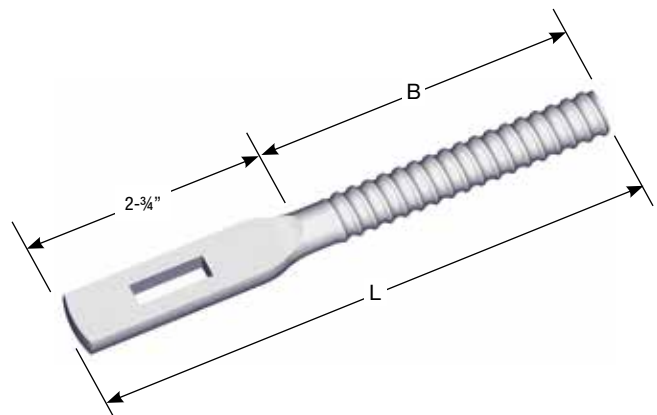



### Coil Form Anchorage



## TYPICAL CANTILEVER FORM

Meadow Burke manufactures and supplies a number of quality coil thread anchors designed to securely attach and support cantilever or "jump" type formwork.

Typical cantilever form anchorage application

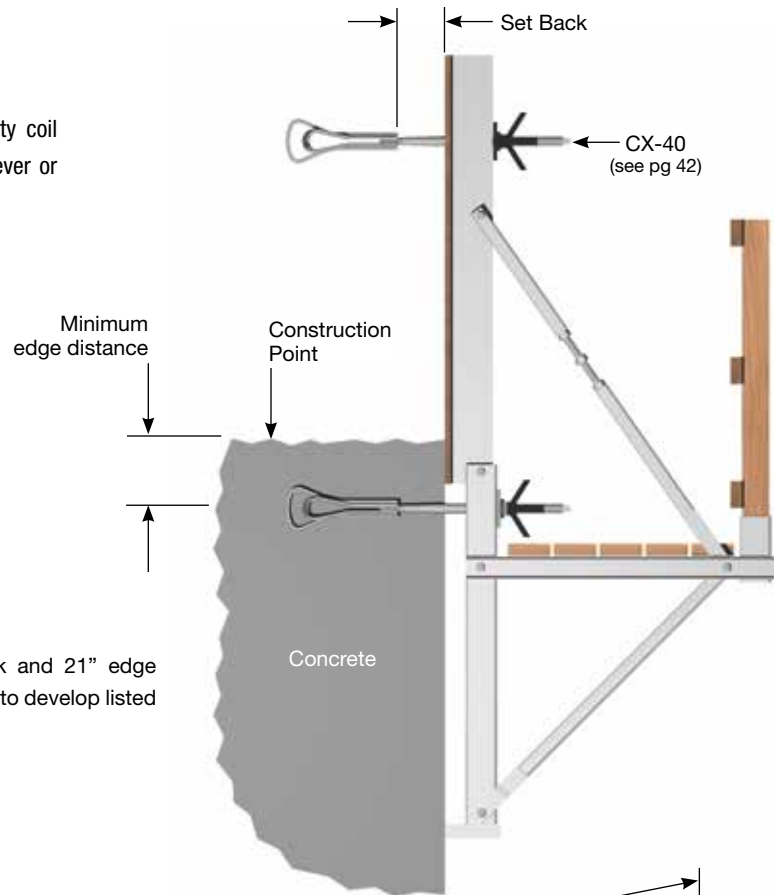
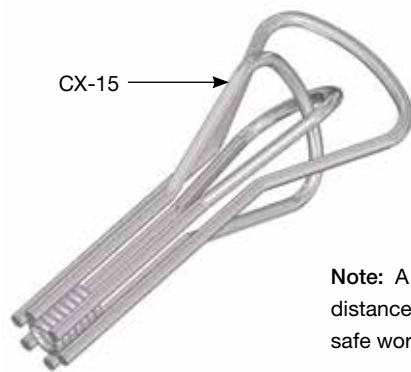

**Note:** A 6" setback and 21" edge distance is required to develop listed safe working loads.

## CX-2 COIL LOOP INSERT - STRAIGHT

The CX-2 Straight Coil Loop Insert is fabricated with one straight loop strut resistance welded to a coil. It is available in diameters from 1/2" through 1-1/4" and in the standard lengths and safe working loads shown in the Table. Other lengths and equipped with Cone-Fast Cones are available on special order. Minimum spacing of inserts shall be double the minimum edge distance.

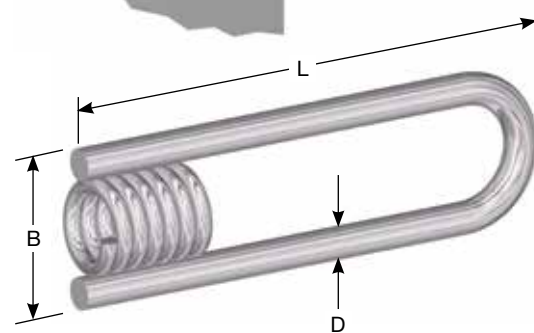

**To Order, Specify: quantity, type, safe working load, bolt diameter and length.**

CX-2 COIL LOOP INSERT - STRAIGHT DATA					
Bolt Dia.	Length (L)	Wire Dia. (D)	B	Safe Work Load (lbs)	Minimum Edge Dist.
1/2"	4"	0.225"	1-1/8"	4,500	7"
1/2"	6"	0.306"	1-1/4"	7,200	10"
3/4"	4"	0.306"	1-5/8"	6,200	7"
3/4"	6"	0.375"	1-3/4"	9,000	10"
1"	6"	0.375"	2-1/8"	9,000	10"
1"	8"	0.375"	2-1/8"	9,000	13"
1-1/4"	8"	0.440"	2-1/2"	12,000	13"

1. Safe working load is based on an approximate 2:1 safety factor, 3,000 psi concrete, and a 1/2" setback from surface of concrete.
2. Minimum coil penetration warning applies.
3. Minimum concrete thickness = L + setback + 3/4" clear cover.

## CX-4 COIL LOOP INSERT – FLARED

The CX-4 Flared Coil Loop Insert is manufactured with a flared loop strut resistance welded to a coil. It is available in diameters from 3/4" through 1-1/2" and in the lengths and safe working loads shown for lifts up to 5'. Minimum spacing of inserts shall be double the minimum edge distance.

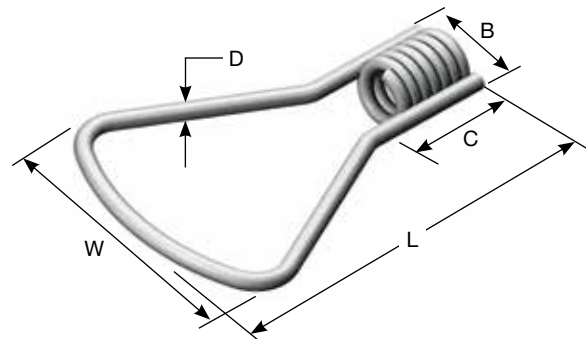

CX-4 COIL LOOP INSERTS - FLARED DATA								
Bolt Diameter	Insert Lgth (L)	Safe Work Load (Tension) (lbs)	Concrete Strength PSI	B	Coil Length (C)	Wire Diameter (D)	Flare Spread (W)	Minimum Edge Distance
3/4"	6"	9,000	2,000	1-3/4"	1-3/4"	.375"	3-1/2"	13"
3/4"	9"	9,000	2,000	1-3/4"	1-3/4"	.375"	5-1/2"	13"
1"	9"	9,000	2,000	2-1/8"	2-1/16"	.375"	5-1/2"	15"
1"	9"	13,500	2,000	2-1/2"	2-1/16"	.440"	5-3/4"	15"
1"	12"	9,000	2,000	2-1/8"	2-1/16"	.375"	5-1/2"	15"
1"	12"	13,500	2,000	2-1/2"	2-1/16"	.440"	5-3/4"	15"
1-1/4"	12"	9,000	2,000	2-1/2"	2-5/16"	.375"	5-3/4"	15"
1-1/4"	12"	15,000	2,000	2-1/2"	2-5/16"	.440"	5-3/4"	15"
1-1/2"	12"	15,000	2,000	2-3/4"	2-9/16"	.440"	5-3/4"	15"

- Safe working load is based on an approximate 2:1 safety factor, 3,000 psi concrete, and a 1/2" setback from surface of concrete.
- Minimum coil penetration warning on applies.
- Minimum concrete thickness = L + setback + 3/4" clear cover.

**To Order, Specify: quantity, type, safe working load, bolt diameter and length.**

## CX-6 COIL LOOP INSERT – DOUBLE FLARED

The CX-6 Double Flared Coil Loop Insert has two flared loop struts resistance welded to the coil. It is available in the diameters, lengths and safe working loads displayed in the Table. This insert is well suited for low strength concrete applications and can easily accommodate 5' to 7-1/2' lifts. This insert can be ordered with straight loops. Minimum spacing of inserts shall be double the minimum edge distance.

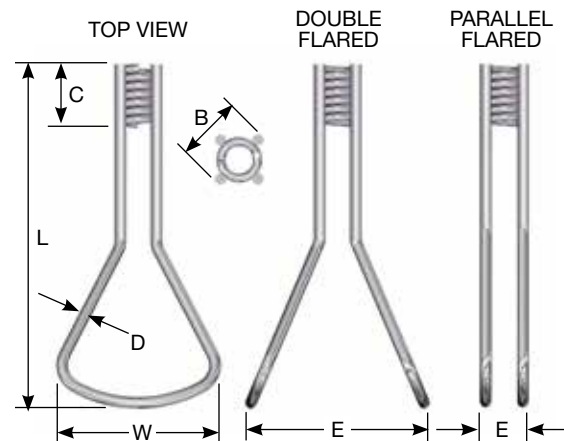

CX-6 COIL LOOP INSERTS - DOUBLE FLARED DATA										
Flare Type	Bolt Diameter	Insert Lgth (L)	Safe Work Load (Tension) (lbs)	Concrete Strength PSI	B	Coil Length (C)	Wire Diameter (D)	Flare Spread (W)	Minimum Edge Distance	E
Parallel	1"	12"	18,000	2,000	2-1/8"	2-1/16"	.375"	5-1/2"	15"	1-1/4"
Parallel	1"	12"	27,000	2,000	2-1/2"	2-1/16"	.440"	5-3/4"	15"	1-1/4"
Parallel	1-1/4"	12"	18,000	2,000	2-1/2"	2-5/16"	.375"	5-3/4"	15"	1-1/2"
Parallel	1-1/4"	12"	32,000	2,000	2-1/2"	2-5/16"	.440"	5-3/4"	15"	1-1/2"
Double	1"	12"	18,000	2,000	2-1/8"	2-1/16"	.375"	5-1/2"	15"	5-3/4"
Double	1"	12"	27,000	2,000	2-1/2"	2-1/16"	.440"	5-3/4"	15"	5-3/4"
Double	1-1/4"	12"	18,000	2,000	2-1/2"	2-5/16"	.375"	5-3/4"	15"	5-3/4"
Double	1-1/4"	12"	32,000	2,000	2-1/2"	2-5/16"	.440"	5-3/4"	15"	5-3/4"
Double	1-1/2"	12"	18,000	2,000	2-3/4"	2-9/16"	.375"	5-3/4"	15"	5-3/4"
Double	1-1/2"	12"	32,000	2,000	2-3/4"	2-9/16"	.440"	5-3/4"	15"	5-3/4"

- Safe working load is based on an approximate 2:1 safety factor, 3,000 psi concrete, and a 1/2" setback from surface of concrete.
- Minimum coil penetration warning applies.
- Minimum concrete thickness = L + setback + 3/4" clear cover.

**To Order, Specify: quantity, type, safe working load, bolt diameter and length.**

## CX-8 COIL LOOP INSERT – CRISS CROSS FLARED

The CX-8 Criss Cross Flared Coil Loop Insert is similar to the double flared insert but has the strut wires welded in a crossing pattern. It is available in 1", 1-1/4" and 1-1/2" diameters and in the lengths and safe working loads shown in the Table. This insert is applicable for 5' to 7-1/2' lifts. Minimum spacing of inserts shall be double the minimum edge distance.

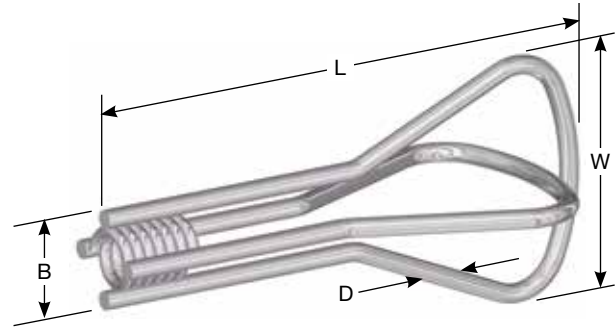

CX-8 CRISS-CROSS INSERT - FLARED DATA							
Bolt Diameter	Insert Lgth (L)	Safe Work Load (Tension) (lbs)	B	Coil Length (C)	Wire Diameter (D)	W	Minimum Edge Distance
1"	12-3/8"	19,000	2-1/16"	2-1/16"	.375"	5-1/2"	15"
1"	12-1/2"	27,000	2-1/4"	2-1/16"	.440"	5-3/4"	15"
1-1/4"	12-3/8"	19,000	2-5/16"	2-1/16"	.375"	5-3/4"	15"
1-1/4"	12-1/2"	27,000	2-1/2"	2-1/16"	.440"	5-3/4"	15"
1-1/2"	12-3/8"	19,000	2-9/16"	2-3/8"	.375"	5-3/4"	15"
1-1/2"	12-1/2"	27,000	2-3/4"	2-3/8"	.440"	5-3/4"	15"

1. Safe working load is based on an approximate 2:1 safety factor, 3,000 psi concrete, and a 1/2" setback from surface of concrete.
2. Minimum coil penetration warning applies.
3. Minimum concrete thickness = L + setback + 3/4" clear cover.

**To Order, Specify: quantity, type, safe working load, bolt diameter and length.**

## CX-9 COIL LOOP INSERT– CRISS CROSS STRAIGHT

The CX-9 Straight Criss Cross Coil Loop Insert is available in 3/4" to 1-1/4" diameters in the lengths and safe working loads shown in the Table. This insert is constructed very much like the flared version but has two straight loops and is well suited for thin wall applications. Minimum spacing of inserts shall be double the minimum edge distance.

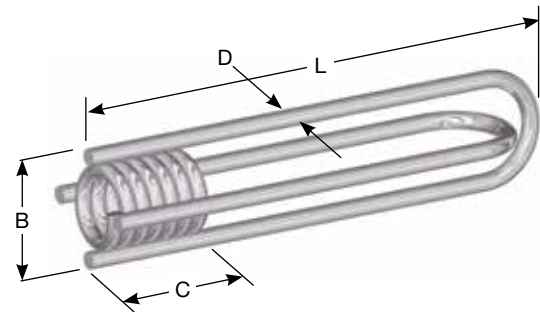

CX-9 COIL LOOP INSERT - CROSS COIL STRAIGHT DATA						
Bolt Diameter	Insert Lgth (L)	Safe Work Load (Tension) (lbs)	B	Coil Length (C)	Wire Diameter (D)	Minimum Edge Distance
3/4"	9"	13,500	1-3/4"	1-5/8"	.306"	24"
3/4"	12"	13,500	1-3/4"	1-5/8"	.306"	24"
1"	9"	13,500	2"	2-1/16"	.306"	24"
1"	12"	13,500	2"	2-1/16"	.306"	24"
1"	9"	18,000	2-1/8"	2-1/16"	.375"	24"
1"	12"	18,000	2-1/8"	2-1/16"	.375"	24"
1-1/4"	9"	27,000	2-1/2"	2-1/16"	.440"	24"
1-1/4"	12"	27,000	2-1/2"	2-1/16"	.440"	24"

1. Safe working load is based on an approximate 2:1 safety factor, 3,000 psi concrete, and a 1/2" setback from surface of concrete.
2. Minimum coil penetration warning applies.
3. Minimum concrete thickness = L + setback + 3/4" clear cover.

**To Order, Specify: quantity, type, safe working load, bolt diameter and length.**

## CX-15 COIL LOOP INSERT – CRISS CROSS HEAVY

The CX-15 Criss Cross Heavy Coil Loop Inserts has three flared loop struts welded to the coil for greater load distribution and shear capacity. It is available in 1-¼” bolt diameter x 15” long. Commonly used with HD-40 on page 42. Minimum spacing of inserts shall be double the minimum edge distance.

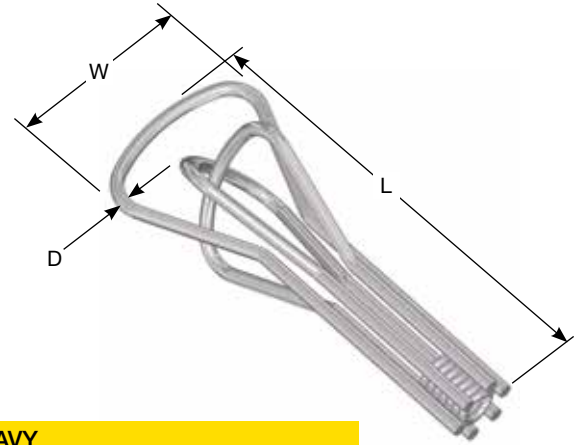

CX-15 COIL LOOP INSERT - CRISS CROSS HEAVY						
Bolt Diameter	Length (L)	Number of Struts	Safe Work Load (lbs)	Wire Diameter (D)	Flare Width (W)	Minimum Edge Distance
1-¼”	15”	6	48,000	0.440	6”	21”

1. Safe working load is based on an approximate 2:1 safety factor, 3,000 psi concrete, and a ½” setback from surface of concrete.
2. Minimum coil penetration warning applies.
3. Minimum concrete thickness = L + setback + ¼” clear cover.

**To Order, Specify: quantity, type, safe working load, bolt diameter and length.**

## CX-24 THIN SLAB INSERT

The CX-24 Thin Slab Insert is a four-strut insert fabricated from deformed wire for increased pullout strength. It is available in ¾”, 1”, 1-¼” and 1-½” diameters. The limited height of the insert makes it effective in thin concrete applications. Minimum spacing of inserts shall be double the minimum edge distance.

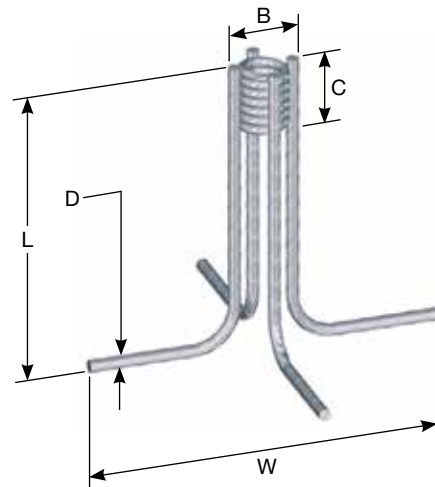

CX-24 COIL LOOP INSERT - DOUBLE FLARED							
Bolt Diameter	Insert Length (L)	Safe Work Load (lbs)	B	Coil Length (C)	Wire Diameter (D)	Flare Width (W)	Minimum Edge Distance
¾”	3”	5,000	1-5/8”	1-3/4”	.306”	7-1/8”	9”
1”	4”	7,000	1-7/8”	2-1/16”	.306”	9-1/2”	12”
1-¼”	4”	8,000	2-1/4”	2-1/16”	.375”	9-3/4”	12”
1-½”	4”	8,000	2-1/2”	2-1/16”	.375”	10”	12”

1. Safe working load is based on an approximate 2:1 safety factor, 3,000 psi concrete, and a ½” setback from surface of concrete.
2. Minimum coil penetration warning applies.
3. Minimum concrete thickness = L + setback + ¼” clear cover.

**To Order, Specify: quantity, type, safe working load, bolt diameter and length.**

## CX-28 COIL WINGNUT INSERT

The CX-28 Coil Wingnut Insert is designed for use in thin slabs or small sections to attach secondary items or they can be used as nut on a length of Coil Rod in forming applications. Refer to the chart for diameters, dimensions and safe working loads. Minimum spacing of inserts shall be double the minimum edge distance.

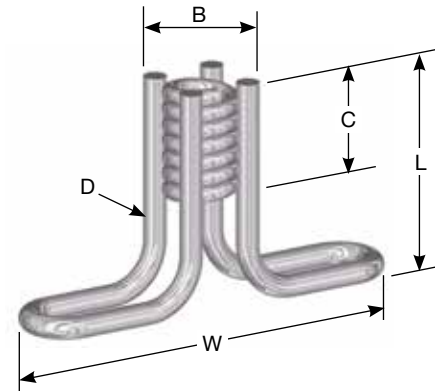

CX-28 COIL WINGNUT INSERT DATA							
Bolt Diameter	Insert Length (L)	Width (B)	Safe Work Load (Tension) (lbs)	B	Coil Length (C)	Wire Diameter (D)	Minimum Edge Distance
1/2"	2-1/4"	4-1/8"	1,900	1-1/4"	1-1/8"	.225"	4"
3/4"	2-1/4"	5"	4,000	1-5/8"	1-5/8"	.262"	5"
3/4"	3-1/2"	6"	6,800	1-3/4"	2"	.306"	6"
1"	2-1/2"	6"	4,000	2"	2"	.306"	5"
1"	4-1/2"	6"	9,500	2"	2"	.306"	8"

1. Safe working load is based on an approximate 2:1 safety factor, 3,000 psi concrete, and a 1/2" setback from surface of concrete.
2. Minimum coil penetration warning applies.
3. Minimum concrete thickness = L + setback + 3/4" clear cover.

**To Order, Specify: quantity, type, safe working load, bolt diameter and length.**

## CX-51 OPEN COIL INSERT

The CX-51 Open Coil Inserts are manufactured with a standard coil connected to an expanded coil by resistance-welded struts. They are available in 3/4", 1", 1-1/4" and 1-1/2" diameters with two to six struts, depending on the model. Refer to the Table for sizes, dimensions and safe working loads. The Open Coil Insert is also available with a mounting washer for applications requiring the insert to be nailed to the form. Minimum spacing of inserts shall be double the minimum edge distance.

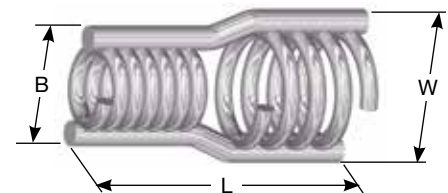

CX-51 OPEN COIL INSERT DATA												
Bolt Diameter	Insert Lgth (L)	Safe Work Load		# of Struts	B	Coil Length (C)	W	Open Coil Lgth (E)	Wire Diameter (D)	Min. Edge Distance		
		Tension	Shear							Tension	Shear <sup>4</sup>	
3/4"	5"	8,500	8,500	2	1-3/4"	1-5/8"	2-1/8"	1-1/2"	.375"	7"	12"	
1"	6"	12,500	12,500	2	2-1/4"	2-1/8"	2-1/2"	2-1/4"	.440"	9"	16"	
1"	8"	20,000	24,000	4	2-1/4"	2-1/8"	2-3/4"	2-3/4"	.440"	12"	24"	
1-1/4"	8"	24,000	24,000	4	2-1/2"	2-1/8"	3"	2-3/4"	.440"	12"	24"	
1-1/4"	10"	32,000	32,000	6	2-1/2"	2-1/8"	3"	3-5/8"	.440"	16"	26"	
1-1/2"	10"	32,000	32,000	6	2-3/4"	2-1/8"	3"	3-5/8"	.440"	16"	26"	

- 1 Safe working load is based on an approximate 2:1 safety factor and 3000 psi concrete. Minimum coil penetration warning applies.
- 2 Minimum concrete thickness = (L) + 3/4" clear cover.
- 3 Minimum corner distance shall be 1.5\* minimum edge distance for shear loaded towards the edge.
- 4 Shear capacity is assumed at surface of the concrete.

**To Order, Specify: quantity, type, safe working load, bolt diameter and length.**

### CT-2 COIL TIE INSERT – TWO STRUT

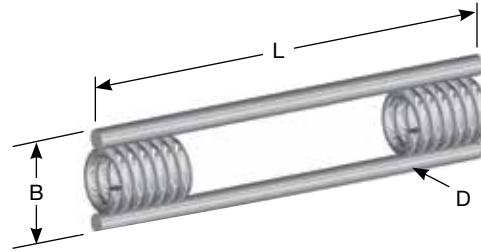

### CT-4 COIL TIE INSERT – FOUR STRUT

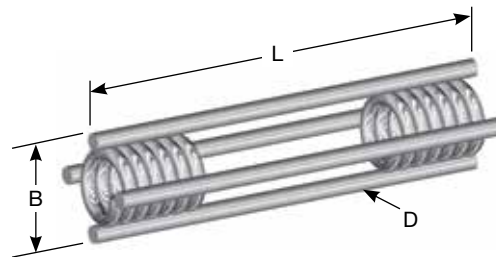

The versatile CT-2 and CT-4 Coil Ties are often used as inserts and are very effective in reanchoring applications. The accompanying Table lists numerous standard sizes to fit a broad range of applications. Other lengths are available, contact a Meadow Burke representative for additional information. Minimum spacing of inserts shall be double the minimum edge distance.

**CT-2 COIL TIE INSERT – TWO STRUT DATA**

Insert Type	Bolt Diameter	Insert Length (L)	Safe Work Load (Tension)	B	Coil Length (C)	Wire Diameter (D)	Minimum Edge Distance
CT-2	3/4"	6"	9,000 lbs	1-5/8"	1-3/4"	.375"	8"
CT-2	1"	6"	12,000 lbs	2-3/8"	2-1/16"	.440"	10"
CT-4	3/4"	6"	12,000 lbs	1-5/8"	2-1/16"	.375"	10"
CT-4	1"	8"	18,000 lbs	2-1/16"	2-1/16"	.375"	10"
CT-4	1"	12"	18,000 lbs	2-1/16"	2-1/16"	.375"	10"
CT-4	1-1/4"	8"	18,000 lbs	2-1/2"	2-1/16"	.440"	10"
CT-4	1-1/4"	12"	27,000 lbs	2-1/2"	2-1/16"	.440"	15"

1. Safe working load is based on an approximate 2:1 safety factor, 3,000 psi concrete, and a 1/2" setback from surface of concrete.
2. Minimum coil penetration warning applies.
3. Minimum concrete thickness = L + setback + 3/4" clear cover.

**To Order, Specify: quantity, type, safe working load, bolt diameter and length.**

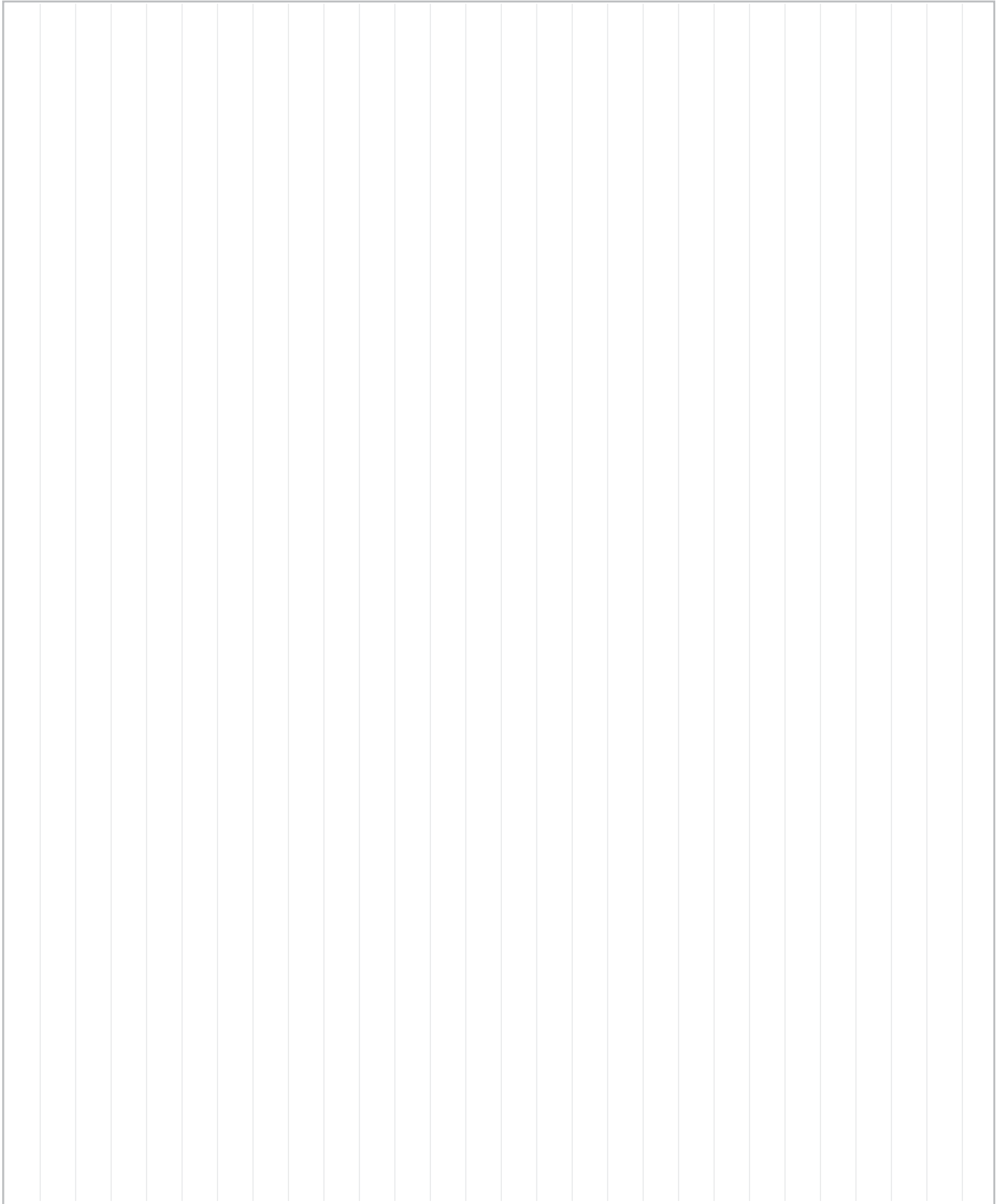

Structural Movement Solutions

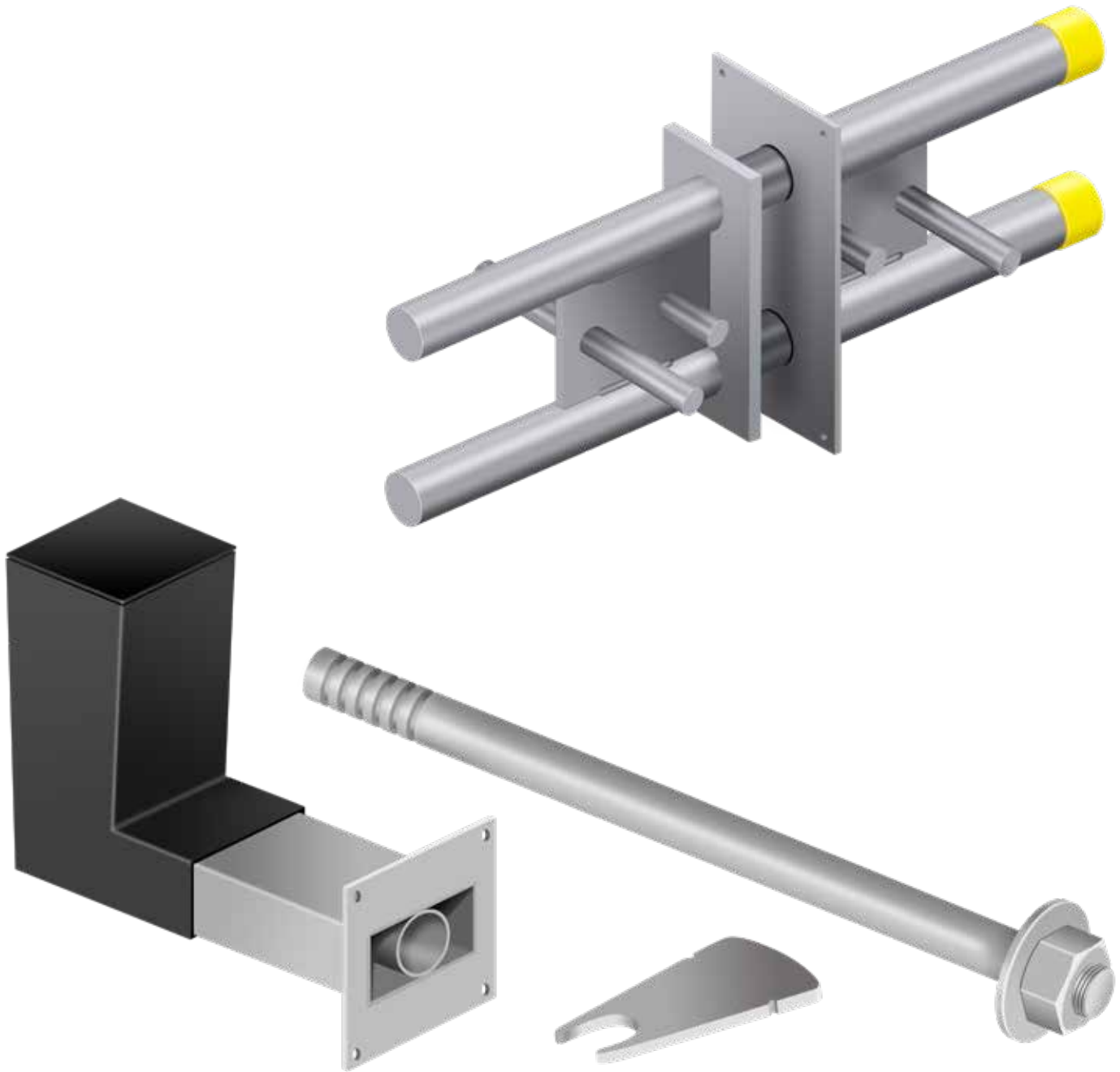

51 - 64

## PERMANENT MOVEMENT SOLUTION: BURKE DOUBLE SHEAR DOWEL

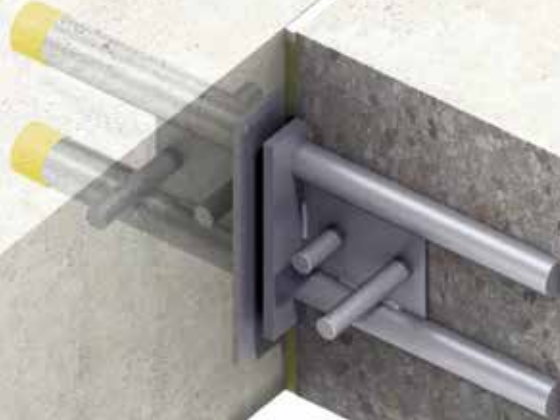

The Burke Double Shear Dowel System offers significant advantages over conventional structural movement methods. The two part assembly is a simple solution that allows longitudinal and/or Lateral movement in building joints. The Burke Double Shear Dowel consists of a sleeve and dowel component.

Quick installation eliminates the need for formwork penetration or concrete protrusions. The easy accurate placement process ensures proper dowel alignment, which is essential for effective movement.

Our shear connectors are manufactured from duplex stainless steel to ensure a high degree of corrosion resistance with no requirement for additional protection.

### BURKE DOUBLE SHEAR DOWEL ASSEMBLY

The Burke Double Shear Dowel is the original two-part, double dowel, shear load connector. The dowel component allows longitudinal movement within the sleeve. The connector is available in 10 standard sizes with design capacities from approximately 4.500 kips to more than 213 kips. The Burke Double Shear Dowel easily accommodates joint widths up to 2-<sup>3</sup>/<sub>8</sub>". Larger joints can be accommodated using special dowels.

### BURKE DOUBLE SHEAR DOWEL – FQ

The Burke Double Shear Dowel–FQ shear load connector utilizes the same dowel (male) component as the Burke Double Shear Dowel in conjunction with a sleeve comprising a rectangular box sleeve to allow lateral movement in addition to the longitudinal movement. There are nine standard sizes with design capacities from approximately 7.8 kips to more than 213 kips.

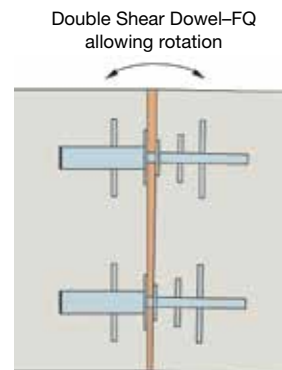

Double Shear Dowel-FQ allowing movement in two directions

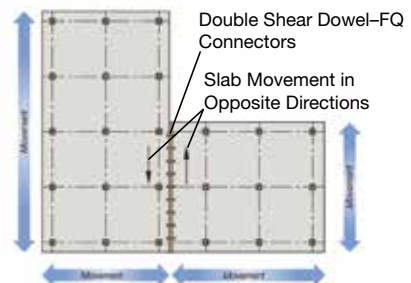

## DOUBLE SHEAR DOWEL

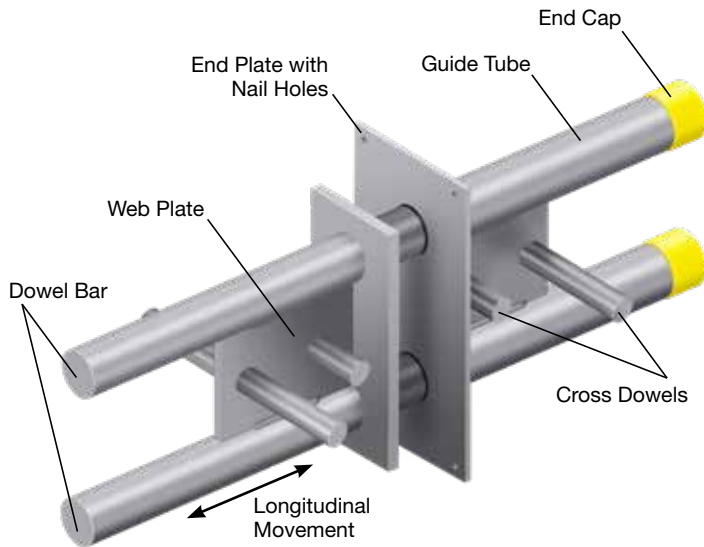

## DOUBLE SHEAR DOWEL-FQ

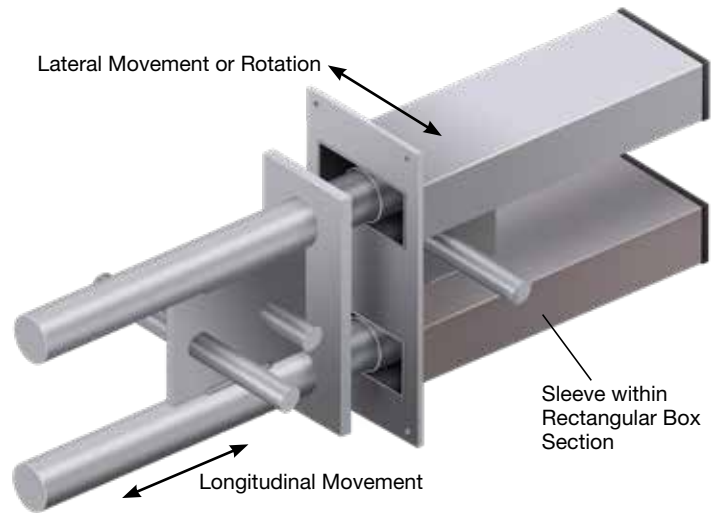

### Conventional Joints - Floor Slab

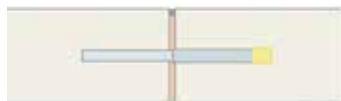

Smooth Dowel

### Floor Slab / Elevated Floor Slab

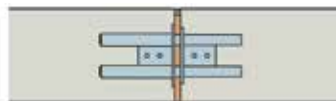

Double Shear Dowel and Double Shear Dowel - FQ

### Wall



Keyed Joint



Double Shear Dowel and Double Shear Dowel - FQ

### Structural Movement Joint

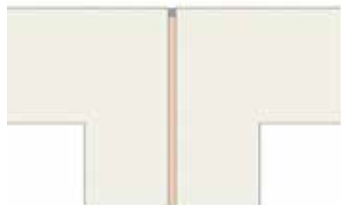

Double Columns

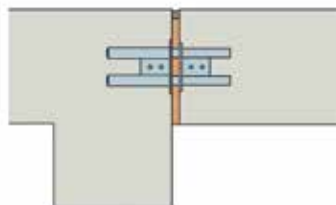

Double Shear Dowel and Double Shear Dowel - FQ

### Floor to Wall Connection



Corbel Support

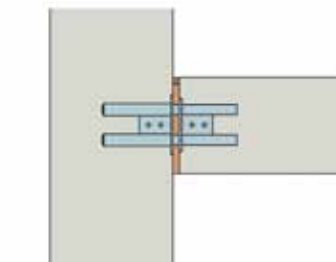

Double Shear Dowel and Double Shear Dowel - FQ

## OUR PROVEN SOLUTION

Accommodating movement during transmission of transverse forces may be accommodated in many ways. Double Shear Dowels provide a proven method to replace dowelled or keyed joints in most cases. The Double Shear Dowel connectors can be used for movement joints in floor slabs, suspended slabs, and keyed joints in walls. They are also ideal for eliminating the need for double columns while opening up a valuable space. They are also an effective solution for costly cast-in-place corbel systems. Corbel support can be eliminated totally while maintaining structural movement. The unique design of the Double Shear Dowel provides significant load improvement over smooth dowels. The example below shows the comparison between one DSD/DSDFQ 130 and six traditional smooth round dowels.

### COMPARISON OF PERFORMANCE with Plain Dowels @ 5,000 psi

15.75" Thick Slab with Joint Width of 0.75"	One MB DSD 130	Six 1.25" Dia Dowel Bars
Dowel Dia inches <sup>2</sup>	2 X 1.375	6 X 1.25
Area of Dowels inches <sup>2</sup>	2.969	7.5
Design Capacity (kip)	55.31	52.14

One Shear Load Connector 130 Design Capacity 45.5 kips

Six Dowel Bars 1.25" Dia Design Capacity 44.4 kips

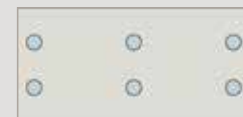
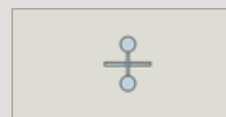

## REINFORCEMENT DETAILS

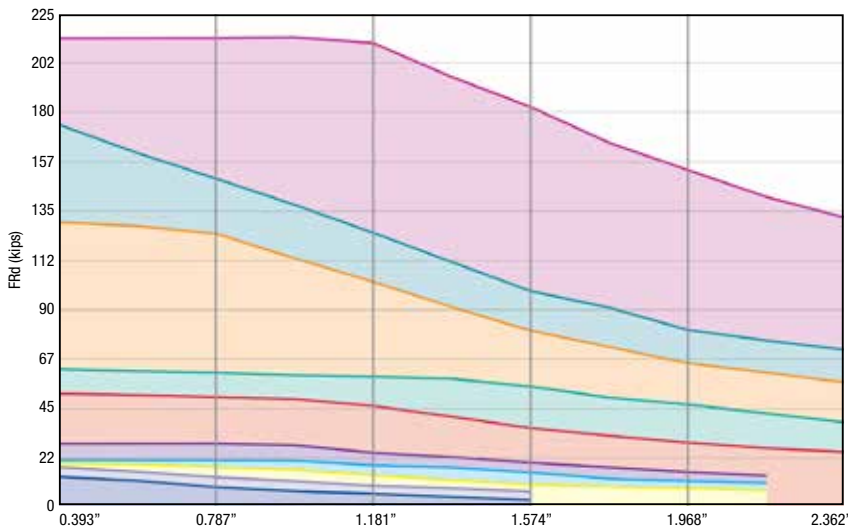

— DSD 450  
— DSD 400  
— DSD 150  
— DSD 130  
— DSD 100  
— DSD 75  
— DSD 65  
— DSD 50  
— DSD 30  
— DSD 25

Burke Double Shear Dowel FRd design capabilities (kips) for various joint widths (mm) at the maximum slab thickness (inch) in 4000 psi concrete

**Based on 3000 concrete, max slab depth & 0.787" joint**  
**Based on 3000 psi, maximum slab depth, .787" joint width**  
**Number of U Bars each side**

DSD/DSDFQ	#3	#4	#5	#6
25	2	-	-	-
30	3	2	-	-
50	3	3	-	-
65	4	3	-	-
75	5	4	-	-
100	-	5	3	-
130	-	-	4	3
150	-	-	6	4
400	-	-	7	5
450	-	-	9	7

## REINFORCEMENT DETAILS

Local reinforcement is required around each connector to guarantee that the forces are transferred between the connectors and the concrete. Correct detailing in accordance with appropriate design codes and the recommendations provided here will ensure Burke Double Shear Dowels attain their full capacity.

The tables show proposals for the type and spacing of the main reinforcement, together with details of reinforcement above and below the connectors.

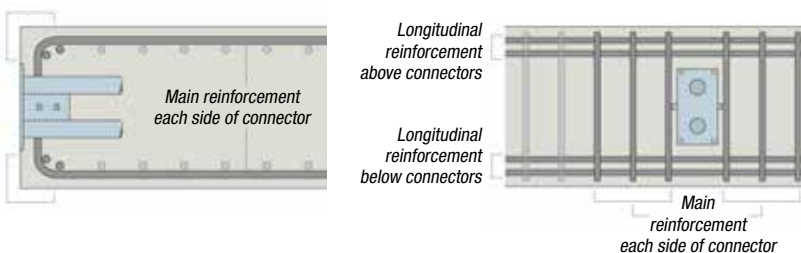

**Number of U Bars Top and Bottom**

DSD/DSDFQ	#3	#4	#5	#6
25	2	-	-	-
30	3	2	-	-
50	3	3	-	-
65	4	3	-	-
75	5	4	-	-
100	-	5	3	-
130	-	-	4	3
150	-	-	6	4
400	-	-	7	5
450	-	-	9	7

**Based on 4000 psi, maximum slab depth, .787" joint width**  
**Number of U Bars each side**

DSD/DSDFQ	#3	#4	#5	#6
25	3	2	-	-
30	-	3	2	-
50	-	3	3	-
65	-	4	3	-
75	-	5	4	3
100	-	-	5	4
130	-	-	-	5
150	-	-	-	-
400	-	-	-	-
450	-	-	-	-

**Number of U Bars Top and Bottom**

DSD/DSDFQ	#3	#4	#5	#6
25	3	2	-	-
30	-	3	2	-
50	-	3	3	-
65	-	4	3	-
75	-	5	4	3
100	-	-	5	4
130	-	-	-	5
150	-	-	-	-
400	-	-	-	-
450	-	-	-	-

## INSTALLATION PROCEDURE

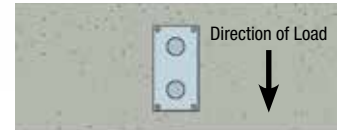

The two-part assembly of all Burke shear connectors removes the need for drilling formwork on site, supporting dowel bars and fitting debonding sleeves and end caps, making the installation process both fast and accurate.



1 Nail the sleeve component to the shuttering ensuring that the sleeve is correctly orientated for the direction of the load. Check that the minimum spacing and edge distances are not exceeded. The label prevents debris from entering into the sleeve aperture and should not be removed at this stage.



2 Fix the local reinforcement in position around the dowel component together with any other reinforcement that is required, ensuring that the correct cover to the reinforcement is maintained. Pour the concrete to complete the installation of the shear connector.



3 When the concrete has achieved sufficient strength, strike the shuttering.



4 Position compressible joint filler of the appropriate width, for applications where movement is expected between the two sections of concrete.



5 Push the dowel component through the joint filler (if applicable) until it is fully located in the sleeve component. It may be necessary to tap the dowel component to overcome the dimple, which pinch holds the dowel in the sleeve and prevents dislocation when the concrete is vibrated.



6 Fix the local reinforcement in position around the sleeve component together with any other reinforcement that is required, ensuring that the correct cover to the reinforcement is maintained.



Notes: (i) Where deep concrete pours are proposed, the installation will require further consideration. More robust fixing of the sleeve and dowel components will be necessary to avoid displacement during placing of the concrete.

## TEMPORARY MOVEMENT SOLUTION: BURKE LOCKABLE DOWEL

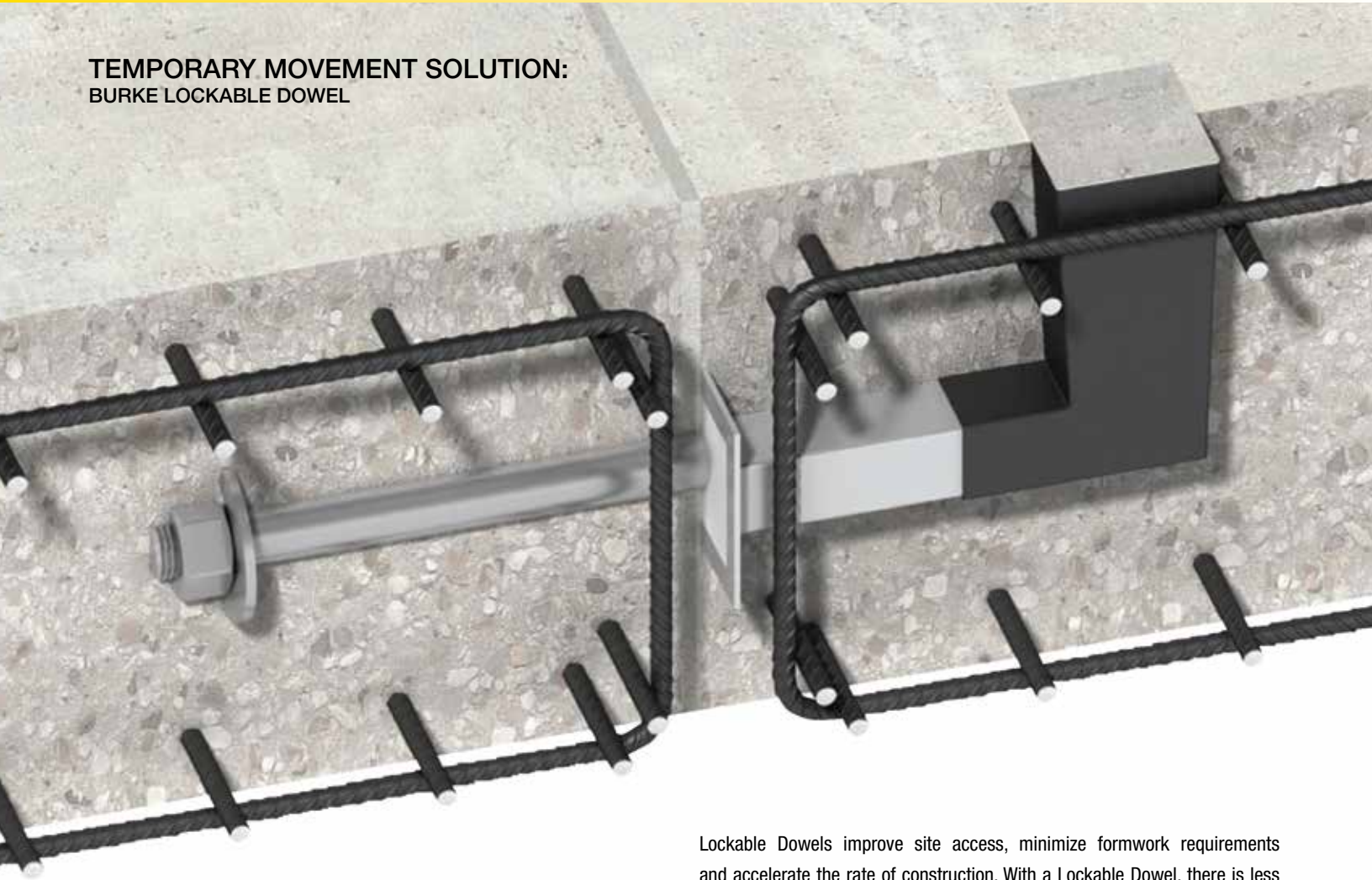

### REVOLUTIONIZING POST-TENSIONED PRECAST CONCRETE

The Burke Lockable Dowel has been designed for use at temporary movement joints, most commonly found in post-tensioned concrete frames.

These dowels allow initial shrinkage of the concrete to take place and are then locked in position with a mechanical plate and a controlled amount of epoxy resin. The locked dowels continue to transfer shear, but prevent further movement taking place.

#### ADVANTAGES

The use of Burke Lockable Dowels can save a significant amount of time and materials over other construction methods. Concrete shrinkage has traditionally been accommodated by leaving gaps in the slab called “pour strips” or “closure strips.” These strips are filled once movement has stabilized, however until they are filled the slabs must be shored, restricting site access and delaying site progress. Gaps in the slab also create a hazard for site workers, use additional formwork and leave the soffit face marked.

Lockable Dowels improve site access, minimize formwork requirements and accelerate the rate of construction. With a Lockable Dowel, there is less requirement for the slabs to be shored or a support corbel to be constructed, as shear load is transferred by the dowel. The time saved by early removal of slab props can be significant.

A Lockable Dowel also provides many advantages over the site-assembled arrangement of carbon steel reinforcing bar, galvanized or plastic ducting, vent tubes and a non-specific grout, which is sometimes used by contractors.

In addition, engineers have found the Burke Lockable Dowel to be the preferred design solution for pin-ended joints. Although it is customary for practical reasons to use U-bars or other rebar continuity systems at these connections, these options do not truly act as hinges and so rotation of the slab under load can induce cracking at the wall-to-slab interface with potential integrity issues.

The Lockable Dowel is closer to a true pin-ended joint and, being manufactured from stainless steel, provides additional corrosion protection over systems using carbon steel reinforcement.

## APPLICATIONS

In most cases, Burke Lockable Dowels can be used to replace pour strips at temporary movement joints in post-tensioned concrete frames. Burke Lockable Dowels and DSD Shear Load Connectors are available for use at slab joints and retaining / core walls.



Traditional Pour Strip

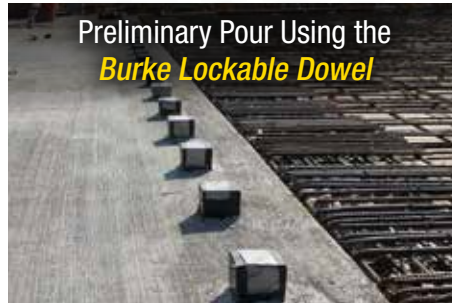

Preliminary Pour Using the **Burke Lockable Dowel**

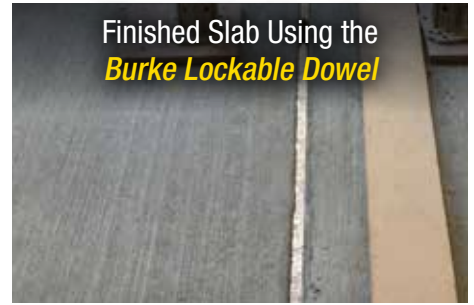

Finished Slab Using the **Burke Lockable Dowel**

### SLAB-TO-SLAB

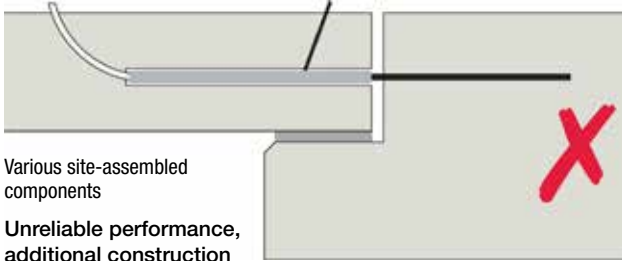

Various site-assembled components  
Unreliable performance, additional construction materials used and support corbel required



Burke Lockable Dowel  
Proven performance  
Minimal material usage



Pour strip in slab

Additional formwork, trip hazard and restricted access  
Slabs shored for several weeks

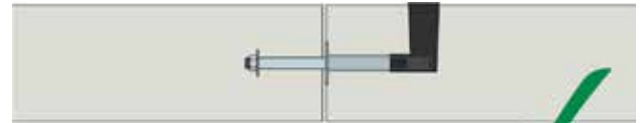

Burke Lockable Dowel  
Proven performance  
Minimal material usage  
Simple installation  
Improved on-site safety

### SLAB-TO-WALL

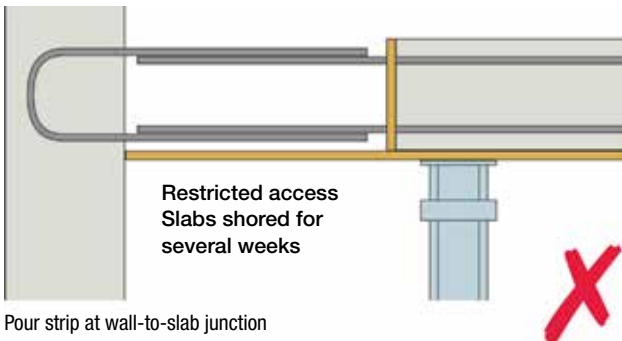

Pour strip at wall-to-slab junction

Restricted access  
Slabs shored for several weeks



Burke Lockable Dowel  
Improved site access  
Reduced shoring time  
Simple installation  
Eliminates framework obstacles

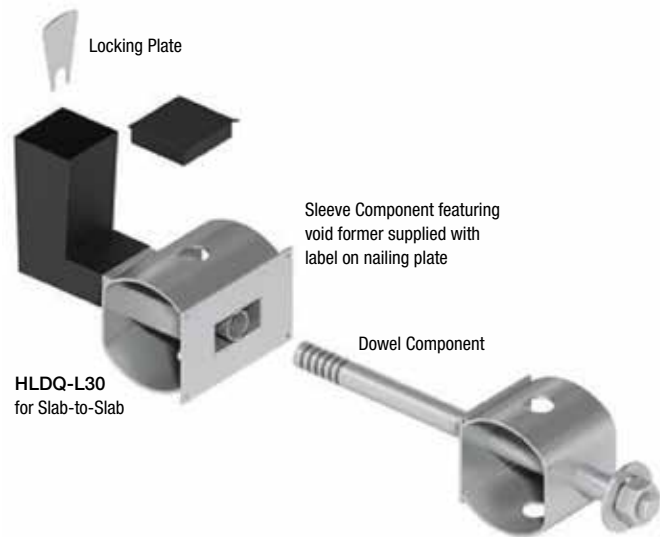
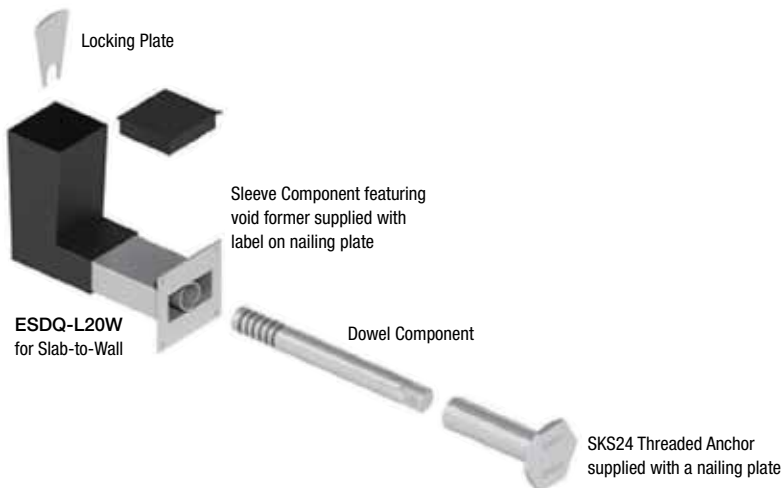
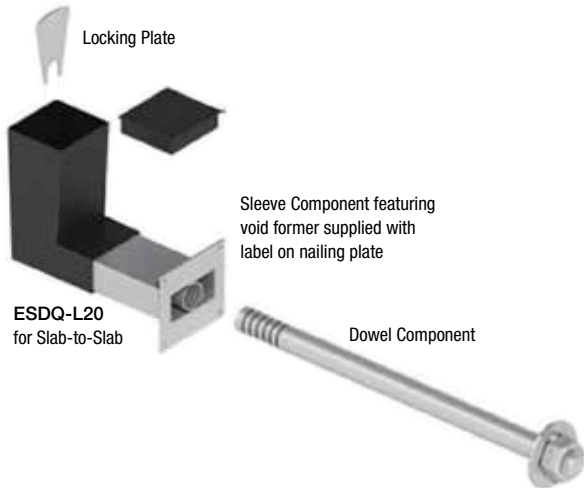

## RANGE OF LOCKABLE DOWELS

A Lockable Dowel allows initial shrinkage of the concrete to take place and then, after a predetermined time period (generally 30 to 90 days), is locked in position with a mechanical plate and a controlled amount of epoxy resin. The range comprises three products; ESDQ-L20, HLDQ-L30 and ESDQ-L20W.

## SLAB-TO-SLAB LOCKABLE DOWELS

### ESDQ-L20

The dowel component is manufactured from 30mm diameter stainless steel; one end is threaded with a fixed nut and washer, and the other features a series of grooves to accept the Locking Plate. The cylindrical sleeve which accepts the dowel component is contained within a box-section to allow lateral, longitudinal and some rotational movement. The epoxy resin is poured into the L-shaped void former. This product has a design capacity of almost two quarts.

## SLAB-TO-WALL LOCKABLE DOWEL

### ESDQ-L20W

The dowel component is manufactured from 30mm diameter stainless steel, but is shorter than the ESDQ-L20 dowel. One end of the dowel is designed to thread into the stainless steel Burke SKS24 Threaded Anchor cast into the face of the concrete and the other end features a series of grooves to accept the Locking Plate. The sleeve component is the same as used in the ESDQ-L20. See pages 6-9 for full technical details.

### HLDQ-L30

The HLDQ-L30 is a high load Lockable Dowel with a design capacity of up to 30.6 kips.

## EPOXY RESIN

Each dowel is locked after a pre-determined time period (generally 3-4 weeks) with a high quality, two-part epoxy resin. The resin is mixed and poured into the L-shaped void former. Each dowel requires 1,500g of resin which can be supplied either in a single can for one application or bulk packaging for locking multiple dowels.



*“The Burke Lockable Dowel is a very clean system compared to pour strips. Pour strips are a nightmare! Pour strips are a mess with all the shoring, safety concerns, cables, cleaning, fill up, and conduit problems. Any extra money spent on the Lockable Dowel is well worth the benefit. The Lockable Dowel saved about 3 weeks with this project. The Lockable Dowel is so clean no one noticed there was a pour strip.*

*If you have encountered pour strips before, the Lockable Dowel is a no brainer.*

*You would be crazy not to use it!”*

Mahmoud Farawi  
Skanska USA  
Raleigh, NC

Two-part Epoxy Resin  
supplied with:

ESDQ-L20  
ESDQ-L20W  
HLDQ-L30

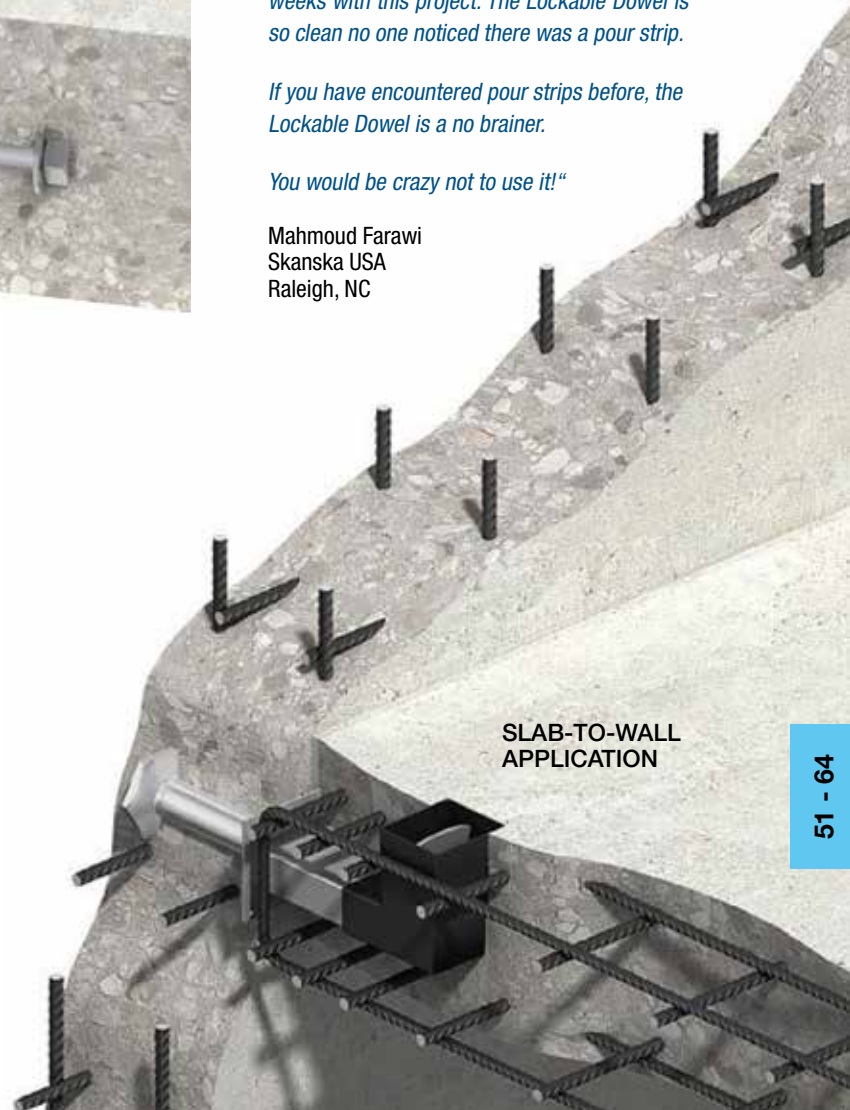

SLAB-TO-WALL  
APPLICATION

## PERFORMANCE DATA

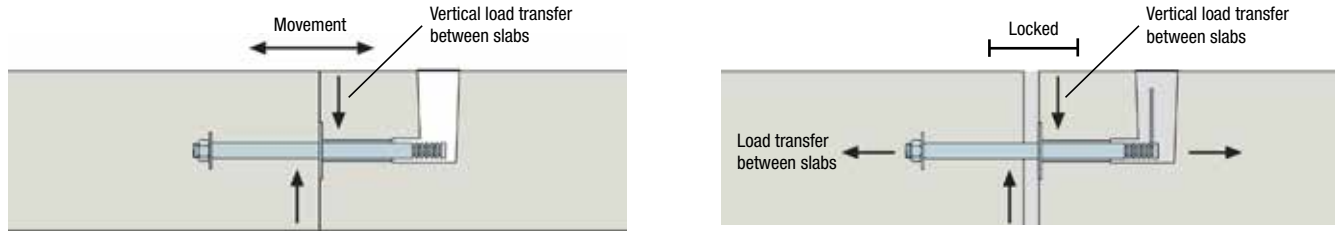

ESDQ-L20 LOCKABLE DOWEL (SLAB-TO-SLAB)									
Slab Thickness	Design Strength Logitudinal Load	Vertical Design Strength (kip) for Various Design Joint Widths in 4000 psi Concrete							
In.	Kip	¼"	½"	¾"	1"	1-¼"	1-½"	2"	
6.25	10.0	2.7	2.7	2.7	2.7	2.7	2.7	2.7	2.7
6.50	10.0	3.4	3.4	3.4	3.4	3.4	3.4	3.4	3.4
7.00	14.6	5.1	5.1	5.1	5.1	5.1	5.1	5.1	5.1
7.50	14.6	5.6	5.6	5.6	5.6	5.6	5.6	5.6	5.6
8.00	18.0	9.0	9.0	9.0	9.0	9.0	9.0	9.0	9.0
8.625	22.5	12.0	12.0	12.0	12.0	12.0	12.0	12.0	10.8
9.00	22.5	13.0	13.0	13.0	12.8	12.2	11.8	10.8	10.8
10.00	22.5	14.0	14.0	14.0	14.0	13.6	13.0	12.4	12.4
11 & Above	22.5	15.7	15.7	14.9	14.2	13.6	13.0	12.5	12.5

ESDQ-L20W LOCKABLE DOWELS (SLAB-TO-WALL)									
Slab Thickness	Design Strength Logitudinal Load	Vertical Design Strength (kip) for Various Design Joint Widths in 4000 psi Concrete							
In.	Kip	¼"	½"	¾"	1"	1-¼"	1-½"	2"	
6.25	10.0	2.7	2.7	2.7	2.7	2.7	2.7	2.7	2.7
6.50	10.0	3.4	3.4	3.4	3.4	3.4	3.4	3.4	3.4
7.00	14.6	5.1	5.1	5.1	5.1	5.1	5.1	5.1	5.1
7.50	14.6	5.6	5.6	5.6	5.6	5.6	5.6	5.6	5.6
8.00	18.0	9.0	9.0	9.0	9.0	9.0	9.0	9.0	9.0
8.625	18.0	12.0	12.0	12.0	12.0	12.0	12.0	12.0	10.8
9.00	18.0	13.0	13.0	13.0	12.8	12.2	11.8	10.8	10.8
10.00	18.0	14.0	14.0	14.0	14.0	13.6	13.0	12.4	12.4
11 & Above	18.0	15.7	15.7	14.9	14.2	13.6	13.0	12.5	12.5

HLDQ-L30 LOCKABLE DOWELS (SLAB-TO-SLAB)									
Slab Thickness	Design Strength Logitudinal Load	Vertical Design Strength (kip) for Various Design Joint Widths in 4000 psi Concrete							
In.	Kip	¼"	½"	¾"	1"	1-¼"	1-½"	2"	
9.50 & Above	22.5	30.6	30.6	30.6	30.6	30.6	30.6	30.6	30.6

All values in the tables above are design load capacities (LRFD) and have to be compared to factored loads.

### ESDQ-L20 EXAMPLE

Slab Thickness = 10"  
 Joint Width = ¾"  
 Concrete Strength = 4,000 psi  
 Actual Load = 6,000 lbf/ft  
 Allowable Vertical Design Load = 14.0 kip (10" slab ¾" joint)  
 Therefore Centers for Vertical Load = 14.0 / 6.0 = 2.33' use 28" centers

Each dowel will in addition provide an allowable tension across the joint of 22.5 kip (for slab to wall this is 18.0 kip), therefore the total allowable tension in the direction of the dowel = 22.5 kip / (28/42) = 9.6 kip/ft (for slab-to-wall 18.0 kip / (28/42) = 7.7 kip/ft).

If this is insufficient, the dowel centers can be reduced to a minimum of 1.5 x slab thickness to increase the allowable tension across the joint, in this example it would increase to 22.5 / (15/42) = 18.0 kip/ft (for slab-to-wall 18.0 kip / (15/42) = 14.4 kip/ft).

## DIMENSIONS

### ESDQ-L20 COMPONENTS

#### DOWEL COMPONENT

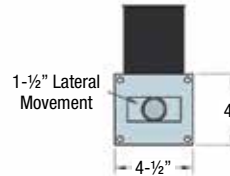
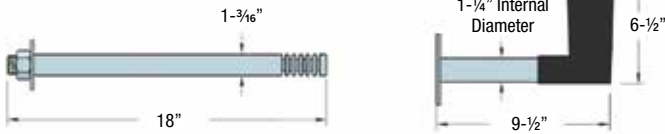

### HLDQ-L30 COMPONENTS

#### DOWEL COMPONENT

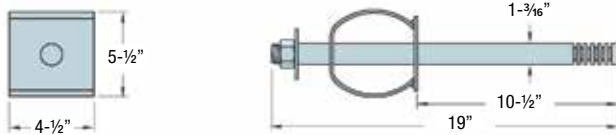

#### SLEEVE COMPONENT



### ESDQ-L20W COMPONENTS

#### SKS24 THREADED ANCHOR

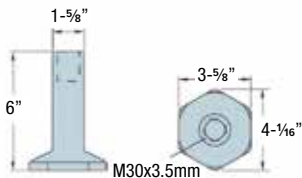

#### DOWEL COMPONENT

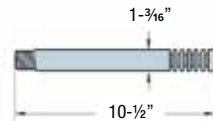

#### SLEEVE COMPONENT

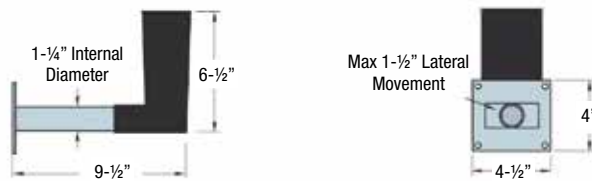

### EDGE DISTANCE AND SPACINGS

For connectors working at or near their maximum capacity, the minimum spacing should be 1.5 times the slab thickness. Where the design load of the connector could be used in a thinner slab, a spacing of 1.5 times the thinner slab thickness can be used. The minimum end distance is always 0.5 times the spacing.

#### ESDQ-L20 EXAMPLE

Slab Thickness = 12"

Joint Width = 1"

Concrete Strength = 4,000 psi

Allowable Load/Connector = 14.2 kip/ft

(based on slabs 10" and above)

Spacing for Max. Load  $12" \times 1.5 = 18"$

End Distance for Max. Load  $18" \times 0.5 = 9"$

Allowable Load/Foot = 14.2 kip/ ( $18/12$ ) = 9.5 kip/ft

As an ESDQ L20 can be used in a 7" slab for a reduced allowable load per connector of up to 9,500 lbf, the spacing can be based on a 7" slab. Therefore:

Reduced Spacing  $7" \times 1.5 = 10-1/2"$

Reduced End Distance  $10-1/2" \times 0.5 = 5-1/4"$

Allowable Load/Foot 9.5 kip/ ( $10-1/2"/12$ ) = 10.8 kip/ft

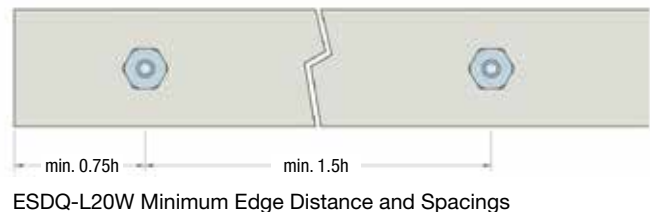
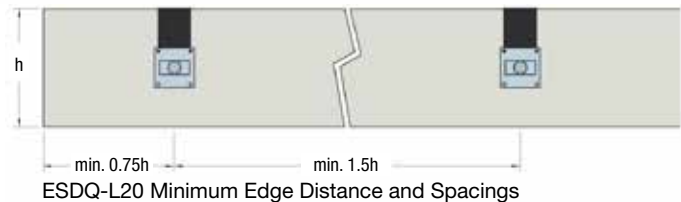

## REINFORCEMENT DETAILS

Local reinforcement is required around each Burke Lockable Dowel to guarantee that the forces are transferred between the connectors and the concrete. Correct detailing in accordance with appropriate design codes and the recommendations provided here will ensure the dowels attain their full capacity.

The tables show the main reinforcement required, together with details of reinforcement above and below the connectors. Although only the sleeve components are illustrated, the same reinforcement is required around the dowel component.

### OPTIONS FOR MAIN REINFORCEMENT

Lockable Dowel Reference	No. of U-bars each Side	
	#4	#5
ESDQ-L20	2	-
HLDQ-L30	4	3

### OPTIONS FOR LONGITUDINAL REINFORCEMENT

Lockable Dowel Reference	No. of Bars Top and Bottom	
	#4	#5
ESDQ-L20	2	-
HLDQ-L30	2	2

ESDQ-L20



HLDQ-L30



SKS24 Threaded Anchor, Part of ESDQ-L20W



ESDQ-L20

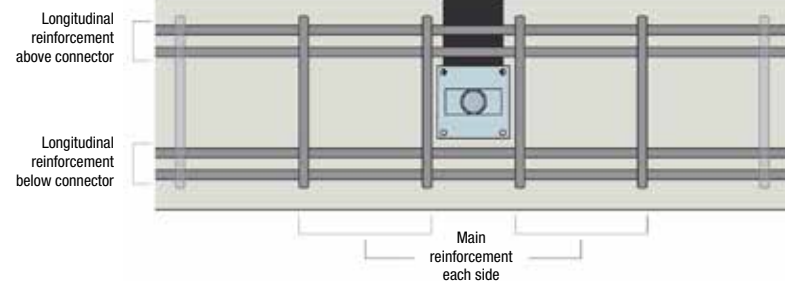

Longitudinal reinforcement above connector

Longitudinal reinforcement below connector

HLDQ-L30

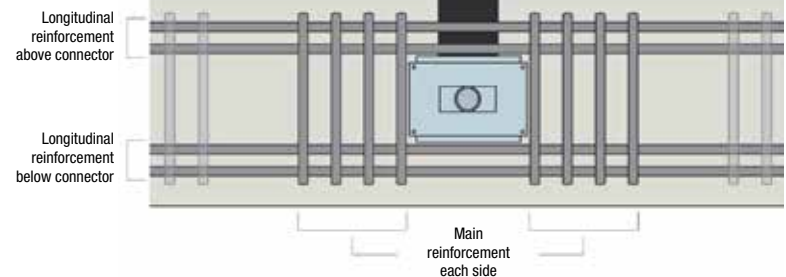

Longitudinal reinforcement above connector

Longitudinal reinforcement below connector

### THREADED ANCHOR

Reinforcement around the Burke Threaded Anchor should be a minimum #4, installed at maximum 8" vertical and horizontal centers.

## INSTALLATION

**SLAB-TO-SLAB:** Although installation is shown for the ESDQ-L20, the procedure is the same for the HLDQ-L30.

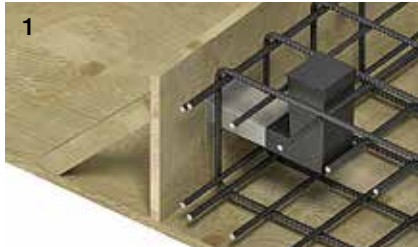

1 Nail the sleeve to the formwork either central in the slab or for slab depths over 12" so the top of the grout box is level with the top of the slab. Do not remove the label over the nailing plate as this prevents ingress of concrete into the sleeve. Fix the local reinforcement.



2 Pour the concrete, and when of sufficient strength, strike the formwork. Puncture the label to reveal the cylindrical sleeve only and insert the dowel until it is completely installed to the back of the grout box.



3 Fix the local reinforcement around the dowel component and pour the concrete.

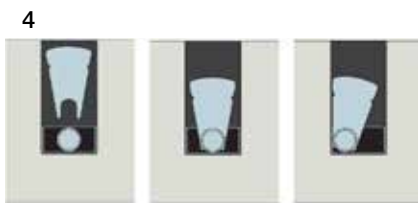

4 After a predetermined time period (generally 60-120 days), when movement between the slabs has stabilized and the joint between the slabs has been filled, the dowel is ready to be locked. Fit the Locking Plate on a groove in the center of the grout box. The fan-shaped Locking Plate allows the dowel to be locked in any position.



5 Mix the two-part epoxy resin and pour into the grout box, ensuring it flows along the stainless steel box section towards the joint.



6 After 24 hours the grout box can be filled with cementitious material, level with the top of the slab, to complete the installation.

The locked dowel continues to transfer vertical load between the slabs, but movement can no longer take place.

## SLAB-TO-WALL



1 Nail the threaded anchor to the formwork so the dowel will be central in the adjoining slab or within 6" of the top of slabs over 12". Fix the local reinforcement and cast the concrete.



2 When concrete reaches sufficient strength, strike the formwork and remove nailing plate. Screw the dowel into the anchor.



3 Puncture the label of the sleeve to reveal the cylindrical sleeve only. Push the sleeve over the dowel until the sleeve front is touching the wall. Tie sleeve to reinforcement and pour concrete.

**Notes:** Where deep concrete pours are proposed, the installation will require further consideration. More robust fixing of the sleeve and dowel components will be necessary, to avoid displacement during casting of the concrete.

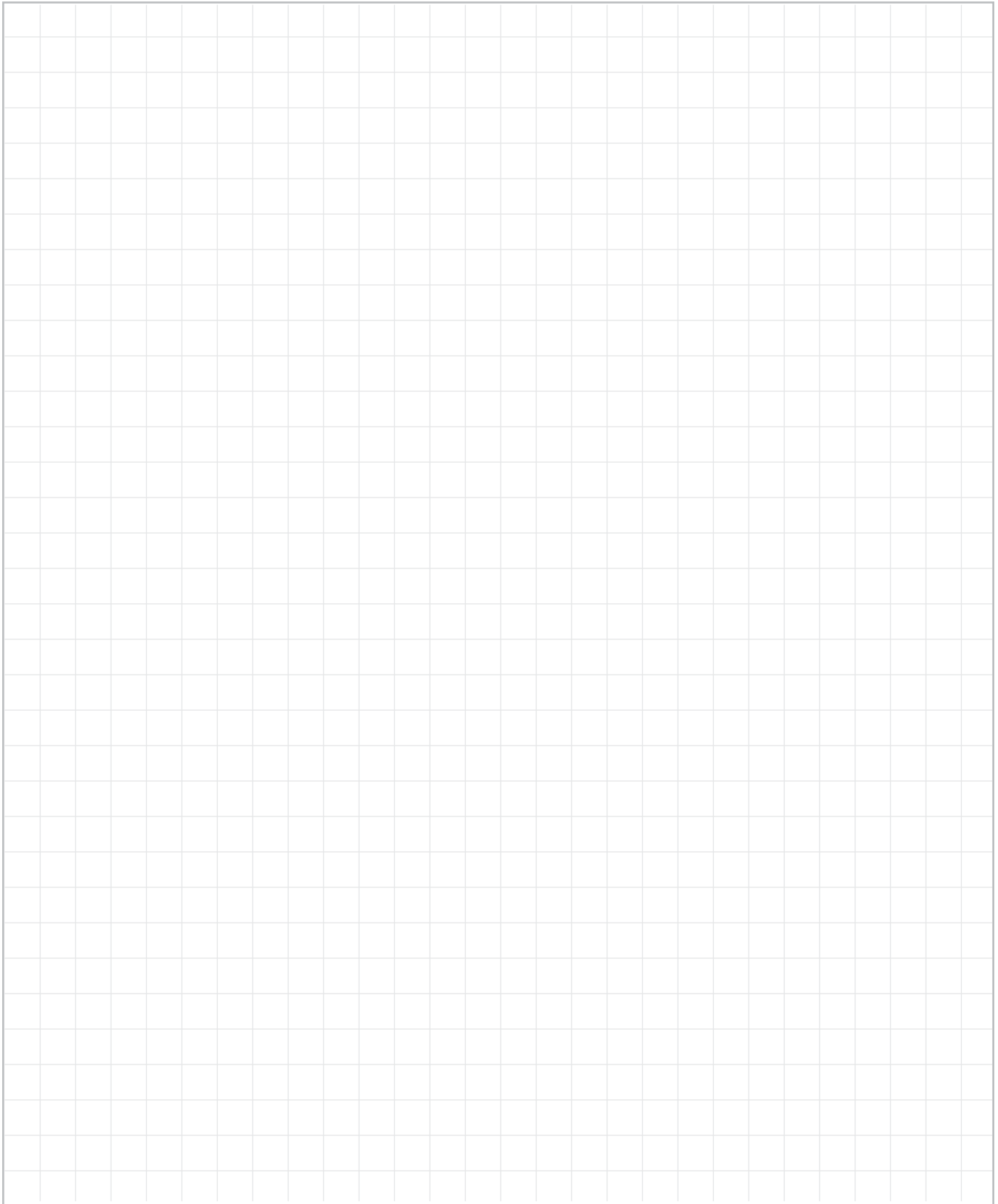

Medium and Heavy Forming Miscellaneous

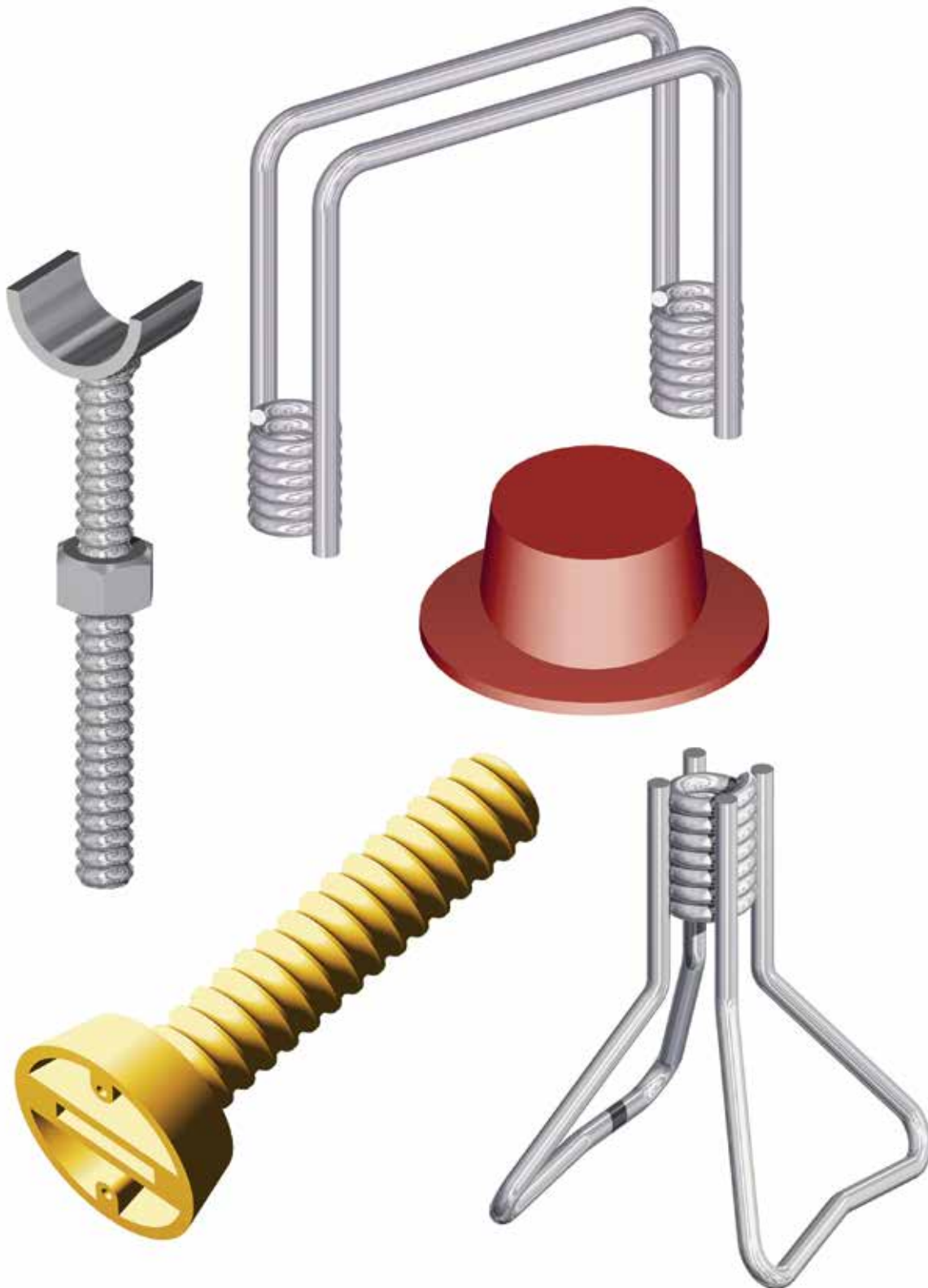

## TIE HOLE PLUGS

Tie Hole Plugs are plastic plugs available in  $\frac{9}{16}$ " and  $\frac{13}{16}$ " diameters used to temporarily fill holes in the formwork plywood.

*To Order, Specify: quantity, type and diameter.*



## CP-2 COIL SETTING PLUG – PLASTIC

The CP-2 Coil Setting Plugs are available in  $\frac{1}{2}$ ",  $\frac{3}{4}$ " and 1" diameters. They are effectively used to set inserts in the form by nailing the plug to the form face and then threading the coil insert onto the plug. The reusable plugs are easily removed from the concrete after the form has been stripped. The Coil Setting Plug can also be used as a temporary cap when another pour will be made at a later time.

CP-2 Coil Setting Plug - Plastic			
Bolt Diameter	D	H	L
in.	in.	in.	in.
$\frac{1}{2}$	$1\frac{3}{8}$	$\frac{1}{2}$	$2\frac{3}{4}$
$\frac{3}{4}$	2	$\frac{3}{4}$	$3\frac{3}{4}$
1	$2\frac{1}{4}$	$\frac{3}{4}$	$5\frac{1}{2}$

Safe working load is based on an approximate 2:1 safety factor.

*To Order, Specify: quantity, type and diameter.*

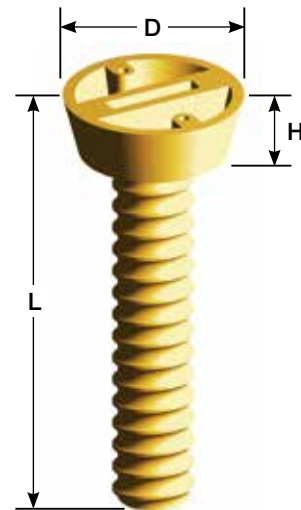

## HF-12 SNAP TIE HANGER - STANDARD

## HF-14 SNAP TIE HANGER - HEAVY

The HF-12 & HF-14 Snap Tie Hangers are manufactured the same as normal snap ties and are then bent to fit specific beam dimensions. Metal washers or plastic spreader cones space the soffit in proper position. The hangers are furnished with a 1/2" breakback to allow the tie to be broken back from the face of the concrete. Snap Tie hangers are available in standard and heavy versions for use with light 2x4 type of forming.

HF-12 & HF-14 SNAP TIE HANGER DATA	
TYPE	SWL in (lbs)
HF-12-Std.	1,500/side
HF-14-Hvy.	2,000/side

Safe working load is based on an approximate 2:1 safety factor.

**To Order, Specify: quantity, type, beam width, beam depth, concrete cover, and lumber and wedge dimension.**

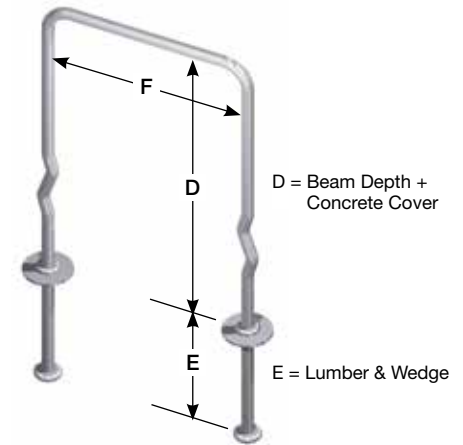

## HF-16 WIRE BEAM SADDLE WITH PLATE HANGER

The HF-16 Wire Beam Saddle Hangers are fixed-length hangers suitable for light slab construction. They are fabricated to specific job requirements and are available in standard and heavy versions for 2x4 or 2x6 joist lumber. These hangers are designed for use with lumber joist material and should not be used to support metal joist applications.

HF-16 WIRE BEAM SADDLE DATA		
TYPE	WIRE	SWL in (lbs)
HF-16-Std.	#7	1,000/side

Not recommended for use on horizontal steel shoring - no warranty or guarantees apply.

Safe working load is based on an approximate 2:1 safety factor.

**To Order, Specify: quantity, type, standard or heavy, beam width, total drop and joist material.**

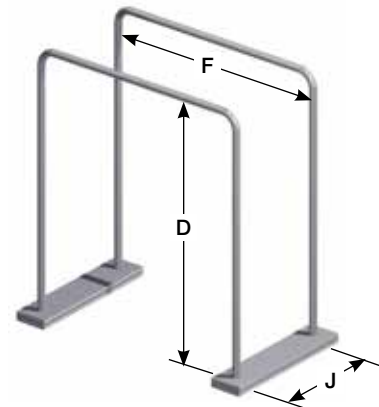

## HF-18 COIL SADDLE HANGER

The HF-18 Coil Saddle Hanger is manufactured the same as a typical Coil Tie and then bent to the dimensions of a specific beam width. Coil Saddle Hangers are available in 3/4" and 1" diameters and in lengths per job requirement. Minimum coil penetration warning applies.

HF-18 COIL SADDLE HANGER DATA		
TYPE	Coil Bolt Dia.	SWL in (lbs)
HF-18	3/4"	5,625/side
HF-18	1"	7,500/side

Safe working load is based on an approximate 2:1 safety factor.

**To Order, Specify: quantity, type, standard or heavy, beam width, total drop and joist material.**

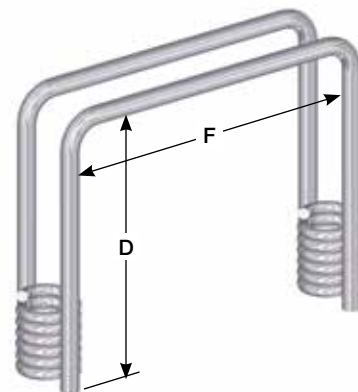

## CX-32 SCREED CHAIR – ADJUSTABLE

### CH-37 PIPE HOLDER

The CX-32 Screed Chair – Adjustable, is available in 1/2" diameter x (2-1/2", 3-1/2", 5-1/2") heights for slabs from 4" up to 11-1/2" and a 3/4" diameter x 5-1/2" height for slabs from 9-1/2" up to 16".

The CH-37 Pipe Holder, is available in 1/2" or 3/4" diameter for use with screed chairs to obtain proper slab heights. To adjust the chair and pipe holder height for grade, hold the pipe holder stationary while turning the chair up or down.

CX-32 SCREED CHAIR & HOLDER DATA					
CX-32 Chair #	Screed Chair Size	CH-37 Pipe #	Pipe Holder Size	Slab Thickness	
				Minimum	Maximum
1	1/2" X 2-1/2"	0	1/2" X 1-1/2"	3-1/2"	4-1/2"
1	1/2" X 2-1/2"	1	1/2" X 3"	4-1/2"	5-1/2"
2	1/2" X 3-1/2"	2	1/2" X 4"	5-1/2"	7-1/2"
3	1/2" X 5-1/2"	3	1/2" X 6"	7-1/2"	11-1/2"
4	3/4" X 5-1/2"	4	3/4" X 8"	9-1/2"	13-1/2"
4	3/4" X 5-1/2"	5	3/4" X 12"	13-1/2"	16-1/2"

All slab heights shown are based on 1" ID pipe (1-1/16" OD)

Warning: Products shown above are not intended to support mechanical screeding machines. For manual screed operations only.

**To Order, Specify: quantity, type, number, diameter, height or length.**

## CX-31 SCREED CHAIR – ADJUSTABLE W/BASE

The CX-31 Screed Chair – Adjustable with Sand Plates, is the same as the CX-32 but with Sand Plates welded to the bottom for use on sand, fill dirt, vapor barrier, or other soft supporting materials. Use with CH-37 Pipe Holder. Table above also applies to the CX-31 Screed Chair.

**To Order, Specify: quantity, type, number, diameter, height or length.**

## CX-33 SCREED CHAIR – METAL DECK

The CX-33 Screed Chair – Metal Deck, is a modified CX-32 flattened to fit low profile and span across steel deck corrugations. Available in both 1/2" and 3/4" diameter.

**To Order, Specify: quantity, type, diameter, height or length .**

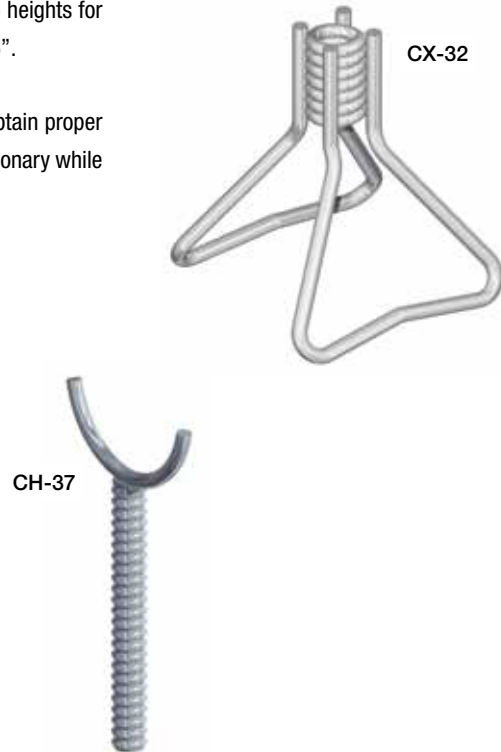

**CX-34 SCREED CHAIR – FILL TYPE**  
**CX-38 SCREED CHAIR – DRIVE TYPE**

The CX-34 Screed Chair – Fill Type, provides four legs for increased stability when used on compacted fill for slab on grade applications. Available in both ½” and ¾” diameter with heights same as CX-32.

The CX-38 Screed Chair – Drive Type, is designed with heavier wire to permit use in more densely compacted sub bases. This chair available in both ½” and ¾” diameter with heights same as the CX-32.

*To Order, Specify: quantity, type, diameter and height.*

**CH-40 SCREED CHAIR – HEAVY DUTY**  
**CH-41 PIPE HOLDER – HEAVY DUTY**  
**CH-42 PIPE HOLDER – HEAVY DUTY WITH SET SCREWS**

The CH-40 Screed Chair – Heavy Duty, is designed as a heavy rigid chair based for use with vibratory screed equipment. This chair is made with four heavy legs equally spaced with cross bracing to prevent leg spreading. The heavy duty base features a single 1” diameter free-fit ferrule (no threads). Available heights are shown in the table below.

The CH-41 Pipe Holder has an open style cradle manufactured from ¼” steel and will accept screed pipe up to 2” O.D. Cradle is welded to a 1” diameter coil rod and includes a 1” diameter coil nut. Height adjustment is made by turning the coil nut which raises or lowers the cradle.

The CH-42 has a closed style cradle and is manufactured from ¼” steel and has two set screws that secures the screed pipe. This cradle accepts screed pipe up to 3” O.D. Cradle is welded to a 1” diameter coil rod and includes a 1” diameter coil nut. Height adjustment is made by turning the coil nut which raises or lowers the cradle.

CH-40, CH-41 & CH-42 HEAVY DUTY SCREED SLAB THICKNESS CHART							
Chair #	Chair Height	Pipe Holder # 4 1”x4-½”		Pipe Holder # 5 1”x6-¾”		Pipe Holder # 6 1”x9-¾”	
		Min.	Max.	Min.	Max.	Min.	Max.
7	3-½”	6-½”	8-½”	-	-	-	-
8	5-½”	8”	10”	9”	12-½”	12”	14-½”
9	8-½”	11”	13”	11-½”	15-½”	12”	18”

Heights based on use of 1-1/2” I.D. pipe (2” O.D.), recommended spacing is 2’0” C/C.  
 Safe working load of 800 lbs is based on an approximate 2:1 safety factor.

*To Order, Specify: quantity, type, diameter, height or length.*

**CS-11 SCREED HOOK**  
**CS-12 SCREED HOOK**

The CS-11 & CS-12 Screed Hooks are available for quick positioning of pipe or rebar for screeding purposes. The hooks can be supported by metal stakes or #5 or #6 rebar driven into the fill. The hooks slide up and down for quick positioning and are securely held in place by the integral set screw. Will support up to #10 bars.

*To Order, Specify: quantity, type, diameter, height or length.*

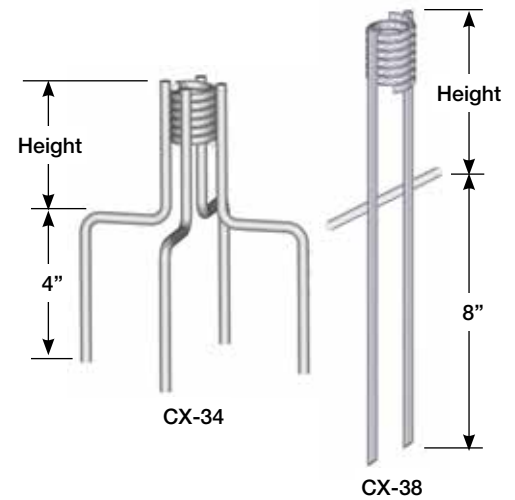

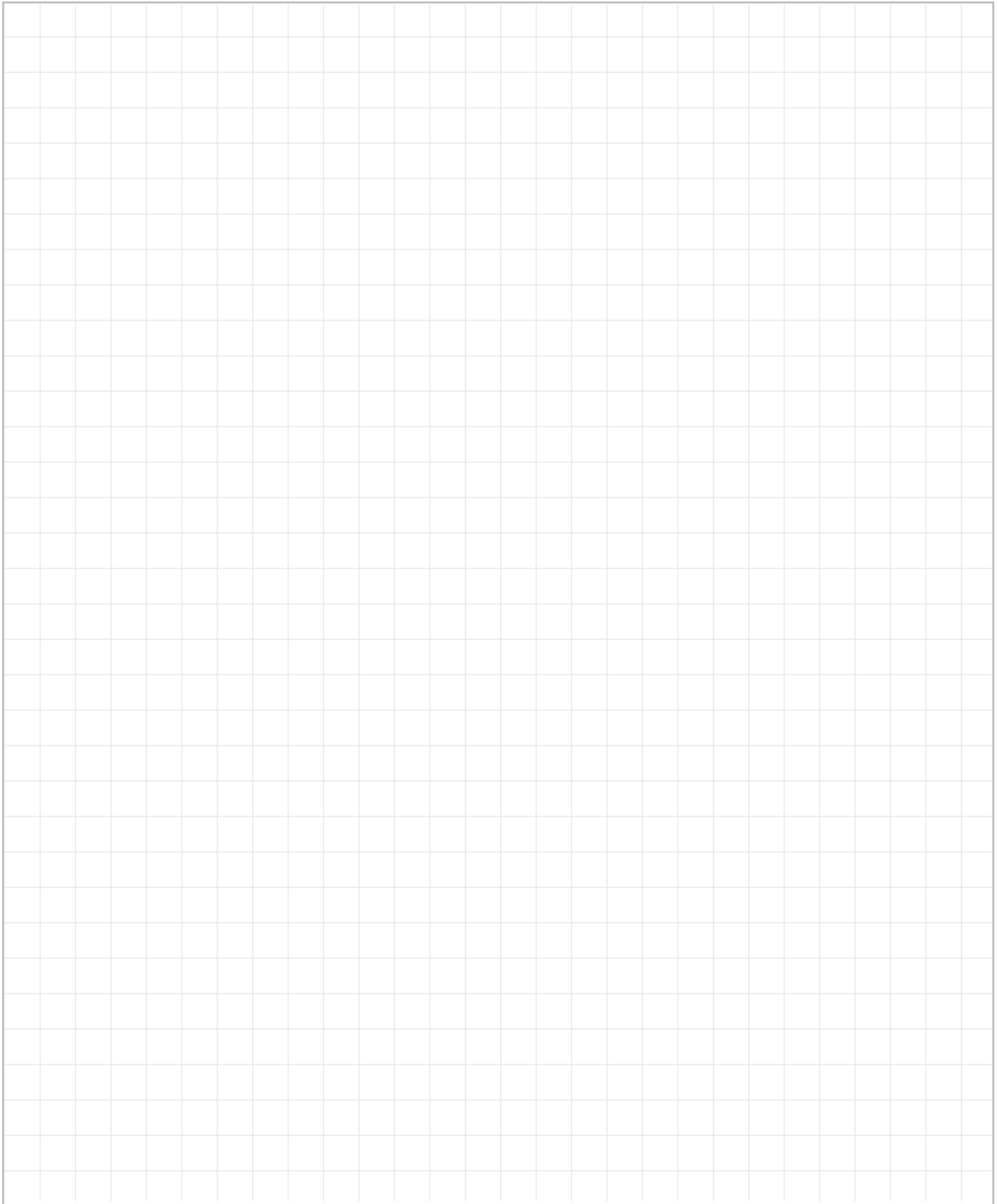

## North American Locations

### California

3611 E La Palma Ave  
Anaheim CA 92806

### Iowa

1000 Technology Drive  
Boone IA 50036

### Texas

7000 Will Rogers Blvd  
Fort Worth TX 76140

### Florida Corporate

6467 S Falkenburg Road  
Riverview FL 33578

### Oregon

155 SE Hazel Dell Way  
Canby OR 97013

### Texas

6500 N Interstate 35  
San Antonio TX 78218

### Georgia

3080 N Lanier Parkway  
Decatur GA 30034

### Pennsylvania

565 Oak Ridge Road  
Hazle Township PA 18202

## Contact Information

### Customer Service

(844) 453-8428 | 844-4-LEVIAT

### Email

[info@leviat.us](mailto:info@leviat.us)

### Engineering Support

(813) 212-5866

### Web

[www.leviat.com](http://www.leviat.com)

## Leviat.com

For information on certified management systems and standards see [www.meadowburke.com](http://www.meadowburke.com) | [www.halfen.com](http://www.halfen.com) | [www.thermomass.com](http://www.thermomass.com)

### Notes regarding this catalogue

© Protected by copyright. The construction applications and details provided in this publication are indicative only. In every case, project working details should be entrusted to appropriately qualified and experienced persons. Whilst every care has been exercised in the preparation of this publication to ensure that any advice, recommendations or information is accurate, no liability or responsibility of any kind is accepted by Leviat for inaccuracies or printing errors. Technical and design changes are reserved. With a policy of continuous product development, Leviat reserves the right to modify product design and specification at any time.

Imagine. Model. Make.