

Road & Bridge





We are one team. **We are Leviat.**

**Leviat is the new name of
CRH's construction accessories
companies worldwide.**

Under the Leviat brand, we have united the expertise, skills and resources of Meadow Burke and its sister companies to create a world leader in fixing, connecting and anchoring technology.

The products you know and trust, including Meadow Burke, will remain an integral part of Leviat's comprehensive brand and product portfolio. As Leviat, we can offer you an extended range of specialist products and services, greater technical expertise, a larger and more agile supply chain and better, faster innovation.

By bringing together CRH's construction accessories family as one global organisation, we are better equipped to meet the needs of our customers, and the demands of construction projects, of any scale, anywhere in the world.

This is an exciting change. Join us on our journey.

Read more about Leviat at Leviat.com



Our product brands include:

MB MeadowBurke®

H
HALFEN

thermomass®



3,000

employees

60

locations

25

countries

4

continents

Imagine. Model. Make.

Leviat.com

General Form Design Information

Safety & Warranty Information	4	Joist Spacing - Double.....	6	Plywood Pressure & Load Chart	8
Lumber Properties	5	Joist Spacing - Single	7		

Standard Bridge Forming

BBS-54 Standard Overhang Bracket	9	Deep Steel Girder up to 3'-0" Overhang	15	BBS-2x4 Guard Rail Receptacle	20
BBS-54 Physical Test Data	10	Deep Steel Girder 3'-0" to 4'-0" Overhang	16	BBS-2x6 Guard Rail Receptacle	20
Screed Wheel Load Per Bracket	11	Concrete Beams up to 2'-0" Overhang	17	BBS Extender for Bridge Overhang Bracket	20
BBS-54 Spacing Tables	12-19	Concrete Beams 2'-0" to 3'-0" Overhang	18	BBS Wall Plate Assembly	21
Steel Girder up to 2'-0" Overhang	12	Deep Concrete Beams 2'-0" to 3'-0" Overhang	19	BBS-47 Burke-Style Bracket	22
Steel Girder 2'-0" to 3'-0" Overhang	13	Overhang	19		
Steel Girder 3'-0" to 4'-0" Overhang	14	BBS-54 Accessories	20-21		

Standard Bridge Hangers

HF-15 Steel Hanger Frame	23	HF-29 Half Hanger	27	HF-39 Broach Hanger 90°/90°	31
HF-17 Steel Hanger Frame	23	HF-33 Side Lock Hanger - 45°	27	HF-40 Adjustable Half Hanger	31
HF-22 Steel Hanger Frame	24	HF-30 / 31 Precast Embed Hanger	28	HF-41 Hook Bolt	31
HF-23 Steel Hanger Frame	24	HF-34 Side Lock Hanger - 90°	29	HF-44 Adjustable Half Hanger - Plate	32
HF-24 Half Hanger	25	HF-35 Side Lock Hanger - 90°	29	HF-64 Hanger For Weld Stud	32
HF-25 Half Hanger (Formed)	25	HF-36 Lock Plate Haunch Hanger	30		
HF-26 High Haunch Steel Hanger Frame	26	HF-37 Clip Hanger	30		
HF-27 High Haunch Steel Hanger Frame	26	HF-38 Broach Hanger 45°/90°	30		

Heavy Bridge Forming

BBA-96 & BBA-96L Overhang Brackets	33-34	BBA Clip Assembly	37	Aluminum Bracket Gang Forming	38-39
Adaptability and Adjustability	35	BBA Joist Beam	37		
Engineering	36	Aluminum Joist Assembly	37		

Heavy Bridge Hangers

HF-61 Super Bar Hanger 45°	41	HF-67 Bulb Tee Bar Hanger	42	HF-76 Haunch Bar Hanger 90°/90°	44
HF-62 Super Bar Hanger 90°	41	HF-73 Adjustable Tandem Bar Hanger	43	HF-77 Haunch Bar Hanger/Lock Plate 45°/90° ...	44
HF-65 Embed Bar Hanger	42	HF-75 Half Haunch Bar Hanger 90°	43		

Miscellaneous Bridge Hardware

CN-29 Coil Wing Nut	45	METAL REINFORCING BAR SUPPORTS		UJC Joist Chair—Upper	53
CW-4 Flat Washer	45	SB Slab Bolster	50	CS Continuous Support (Zig-Zag)	53
CN-5 Coil Nut—Standard	46	SBR Slab Bolster—Upper	50	Wire Girder—Double	53
CN-25 Coil Nut—Heavy	46	BB Beam Bolster	50	SBB Slab Beam Bolster	53
CB-2 Coil Bolt	47	UBB Beam Bolster—Upper	51	X Tuff Slab Bolster	54
CB-4 Adjustable Coil Bolt	47	CHC Continuous High Chair	51	MB Tuff Chair	54
CX-32 Screed Chair—Adjustable	48	UCHC Continuous High Chair—Upper	51	MCB Mesh Chair with Base	54
CH-37 Pipe Holder	48	CHCM Continuous High Chair—Metal Deck	51	PC-2 Snap-On Mesh Chair	54
CX-34 Screed Chair—Fill Type	49	HCMD High Chair—Metal Deck	51	PC-3 Snap-On Mesh Chair with Base	54
CX-38 Screed Chair—Drive Type	49	FC-12 Foundation Chair	52	PC-4 Snap-On Paving Chair with Base	54
CH-40 Screed Chair—Heavy Duty	49	FC-16 Foundation Chair	52	PC-5 Snap-On Bar Chair	54
CH-41 Pipe Holder—Heavy Duty	49	FC-20 Foundation Chair (12", 16", 20)	52		
CH-42 Pipe Holder—Heavy Duty w/Set Screws	49	HC High Chair	52		
CS-11 Screed Hook	49	BC Bar Chair	52		
CS-12 Screed Hook	49	JC Joist Chair	52		

Submittal Forms and Engineering Details

Welding Procedures	55	Engineering Submittal Form	57-61	Index	65
Bridge Hanger Repair Procedures	56	Typical Detail Drawings	62-64		

SAFETY & WARRANTY INFORMATION

Meadow Burke guarantees its products, as shipped from the factory and when the above factors are taken into account. These products are intended for use by qualified and experienced workmen. Even slight misuse, misapplication or lack of supervision and inspection can contribute to serious accidents. Unusual applications beyond the scope of Meadow Burke bulletins, brochures, catalogs or drawings should be carefully field-tested before general product use.

CHANGES IN PRODUCT DESIGN

Meadow Burke reserves the right to change product designs, safe load ratings and product dimensions at any time without prior notice to users. Such changes will be made only for product improvement or additional safety.

WORN WORKING PARTS

It is the user's responsibility to continually inspect working hardware for wear, and to discard the parts when wear is noted. Do not straighten bent bolts, rather discard and replace. Discard any bolts known to have been used at loads of 70% ultimate strength or more. Such bolts may have been stretched sufficiently to become brittle-hard.

DYNAMIC

All rated safe working loads and safety factors shown in this catalog are for "static" loading conditions. If shock, dynamic, or impact forces are anticipated, additional safety factors must be applied.

SHOP OR JOB SITE ARC WELDING

DO NOT WELD TO ANY WIRE PRODUCTS, unless in the opinion of a qualified engineer, such welding is in a non-critical area. Welding to wire products causes embrittlement at the load point and greatly reduces the load carrying capacity. Tack welding of wire products can have the same effect. Since Meadow Burke is not able to control field conditions or field workmanship, Meadow Burke DOES NOT GUARANTEE any of its products which have been altered in any way (including field welding or bending) after leaving the factory.

SAFE WORKING LOAD DIRECTION

All SWL's for the hangers shown in this catalog are axial loads for which the hangers are rated. The hanger SWL is in the direction of the hanger coil rod. Depending on the angle of the rod in a particular bracket configuration, the vertical load which can be supported by the bracket (bracket SWL) may be less than the hanger SWL.

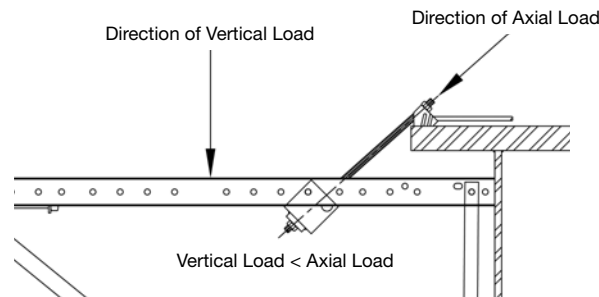

AVAILABLE FINISHES AND COATINGS

PLAIN – Unprotected steel sometimes referred to as black, basic or raw steel. It will corrode or rust when exposed to the elements.

HOT-DIPPED GALVANIZED – Available upon request.

ELECTRO-PLATED – Available upon request.

WARRANTY

Meadow Burke will refund the price of, or replace at its election, any product which it finds to be defective, provided the product has not been misused. Except as stated above, Meadow Burke assumes no liability for delay caused by defects, for loss of use, for any charges or expenses of any nature incurred without its written consent. The foregoing statement covers the full extent of responsibility of Meadow Burke even though they may have been negligent.

The user of Meadow Burke Products must evaluate the product application, determine the appropriate safe working load and control and field conditions to prevent application of loads in excess of the safe load.

LUMBER PROPERTIES

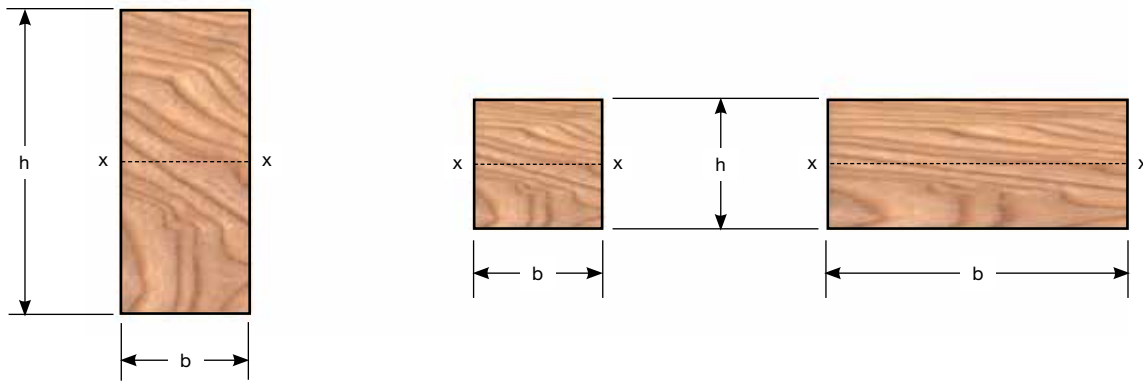

PROPERTIES OF STRUCTURAL LUMBER

Nominal Size (in.) b x h	American Standard Size (in.) b x h S4S* 19% Maximum Moisture	Area of Section A = bh, (sq in.)		Moment of Inertia (in.) $I = \frac{bh^3}{12}$		Section Modulus (in.) $S = \frac{bh^2}{6}$		Board Feet (per lineal ft of piece)	Approx. Weight (lbs per lineal ft),
		Rough	S4S	Rough	S4S	Rough	S4S		
4 x 2	3-1/2 x 1-1/2	5.89	5.25	1.30	0.98	1.60	1.31	2/3	1.5
6 x 2	5-1/2 x 1-1/2	9.14	8.25	2.01	1.55	2.48	2.06	1	2.3
8 x 2	7-1/4 x 1-1/2	11.98	10.87	2.64	2.04	3.25	2.72	1-1/3	3.0
10 x 2	9-1/4 x 1-1/2	15.23	13.87	3.35	2.60	4.13	3.47	1-2/3	3.9
12 x 2	11-1/4 x 1-1/2	18.48	16.87	4.07	3.16	5.01	4.21	2	4.7
2 x 4	1-1/2 x 3-1/2	5.89	5.25	6.45	5.36	3.56	3.06	2/3	1.5
2 x 6	1-1/2 x 5-1/2	9.14	8.25	24.10	20.80	8.57	7.56	1	2.3
2 x 8	1-1/2 x 7-1/4	11.98	10.87	54.32	47.63	14.73	13.14	1-1/3	3.0
2 x 10	1-1/2 x 9-1/4	15.23	13.87	111.58	98.93	23.80	21.39	1-2/3	3.9
2 x 12	1-1/2 x 11-1/4	18.48	16.87	199.31	177.97	35.04	31.64	2	4.7
3 x 4	2-1/2 x 3-1/2	9.52	8.75	10.42	8.93	5.75	5.10	1	2.4
3 x 6	2-1/2 x 5-1/2	14.77	13.75	38.93	34.66	13.84	12.60	1-1/2	3.8
3 x 8	2-1/2 x 7-1/4	19.36	18.12	87.74	79.39	23.80	21.90	2	5.0
3 x 10	2-1/2 x 9-1/4	24.61	23.12	180.24	164.89	38.45	35.65	2-1/2	6.4
3 x 12	2-1/2 x 11-1/4	29.86	28.12	321.96	296.63	56.61	52.73	3	7.8
4 x 4	3-1/2 x 3-1/2	13.14	12.25	14.39	12.50	7.94	7.15	1-1/3	3.4
4 x 6	3-1/2 x 5-1/2	20.39	19.25	53.76	48.53	19.12	17.65	2	5.3
4 x 8	3-1/2 x 7-1/4	26.73	25.38	121.17	111.15	32.86	30.66	2-2/3	7.0
4 x 10	3-1/2 x 9-1/4	33.98	32.38	248.91	230.84	53.10	49.91	3-1/3	9.0

* Rough dry sizes are 1/8" larger, both dimensions.

† Based on a unit weight value of 40 lb. per cu. ft. Actual weights vary depending on species and moisture content.
Data supplied by the National Forest Products Association

JOIST SPACING – DOUBLE

Safe Spacing (ℓ) in Inches of Supports for Double Ledger Continuous Over Three or More Spans
 $\phi_{max} = \ell/360$, but not to exceed $1/4"$

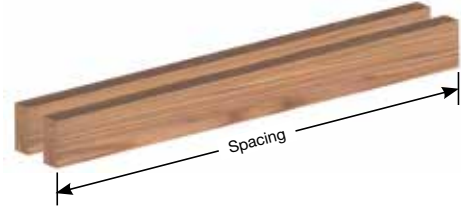

SIMPLE SPAN DOUBLE-PLY LEDGER								
Equivalent Uniform Load (lbs per lineal ft)	Shear Parallel to Grain, $F_v' = 175$ psi, Modulus of Elasticity, $E' = 1600000$ psi							
	Nominal Size of S4S Lumber							
	2 x 4	2 x 6	2 x 8	2 x 10	2 x 12	3 x 6	4 x 4	4 x 8
	Fb (psi) =							
	1500	1250	1200	1050	975	1250	1500	1200
100	73	108	133	160	185	123	95	165
200	58	91	112	135	156	104	77	139
300	51	80	101	122	141	94	67	125
400	46	69	89	113	131	86	61	117
500	43	62	80	103	121	80	57	110
600	39	56	73	94	111	73	54	105
700	36	52	67	87	102	67	51	101
800	34	49	63	82	96	63	49	96
900	32	46	59	77	90	59	47	91
1000	30	43	56	73	86	56	45	86
1200	27	40	51	67	78	51	42	79
1400	25	37	47	62	72	47	39	73
1600	24	34	44	58	68	44	36	68
1800	22	32	42	54	64	42	34	64
2000	21	31	40	51	60	40	33	61
2200	20	29	38	49	58	38	31	58
2400	19	28	36	47	55	36	30	55
2600	18	27	35	45	53	35	28	53
2800	18	26	33	43	51	33	27	51
3000	17	25	32	42	49	32	26	50

1. All values based on 2005 NDS for lumber species with the above properties
2. The following load factors have been considered in the above tables: $C_d = 1.25$, $C_{M,b} = 0.85$ (1.0 for 2 x 10 & 2 x 12), $C_{M,v} = 0.97$, $C_{M,E} = 0.9$
3. $\phi_{max} = \ell/360$, but not to exceed $1/4"$
4. All values based on worst case of deflection, bending or shear
5. All values above the bold line are controlled by deflection. Bending and shear govern below.

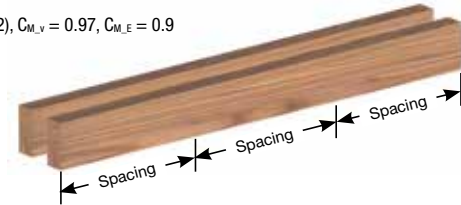

Safe Spacing (ℓ) in Inches of Supports for Double Ledger Continuous Over Three or More Spans
 $\phi_{max} = \ell/360$, but not to exceed $1/4"$

MULTI-SPAN DOUBLE-PLY LEDGER								
Equivalent Uniform Load (lbs per lineal ft)	Shear Parallel to Grain, $F_v' = 175$ psi, Modulus of Elasticity, $E' = 1600000$ psi							
	Nominal Size of S4S Lumber							
	2 x 4	2 x 6	2 x 8	2 x 10	2 x 12	3 x 6	4 x 4	4 x 8
	Fb (psi) =							
	1500	1250	1200	1050	975	1250	1500	1200
100	91	127	156	188	217	144	112	193
200	72	107	131	158	183	121	94	163
300	62	89	115	143	165	110	83	147
400	54	77	100	129	152	100	76	137
500	48	69	89	116	136	89	70	129
600	44	63	81	105	1254	81	66	123
700	40	58	75	98	114	75	62	115
800	38	54	70	91	107	70	58	108
900	36	51	66	86	101	66	55	102
1000	34	49	63	82	96	63	52	96
1200	31	44	57	74	87	57	47	88
1400	28	41	53	69	81	53	44	81
1600	27	38	50	64	76	50	41	76
1800	25	36	47	61	71	47	38	72
2000	24	34	44	58	68	44	36	68
2200	23	33	42	55	64	42	35	65
2400	22	31	40	52	62	40	33	62
2600	20	30	39	50	59	39	32	60
2800	19	29	37	49	57	37	31	57
3000	18	28	36	47	55	36	30	55

1. All values based on 2005 NDS for lumber species with the above properties
2. The following load factors have been considered in the above tables: $C_d = 1.25$, $C_{M,b} = 0.85$ (1.0 for 2 x 10 & 2 x 12), $C_{M,v} = 0.97$, $C_{M,E} = 0.9$
3. Multi-spans continuous over 3 spans or 4 supports
4. $\phi_{max} = \ell/360$, but not to exceed $1/4"$
5. All values based on worst case of deflection, bending or shear
6. All values above the bold line are controlled by deflection. Bending and shear govern below.

JOIST SPACING – SINGLE

Safe Spacing (ℓ) in Inches of Supports for Joists, Studs, etc. Single Span
 $\varnothing_{\max} = \ell/360$, but not to exceed $1/4"$

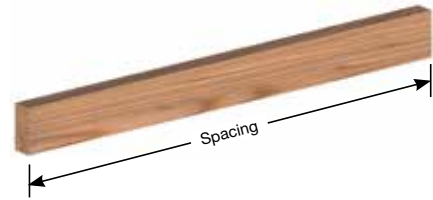

SIMPLE SPAN SINGLE-PLY LEDGER								
Equivalent Uniform Load (lbs per lineal ft)	Shear Parallel to Grain, $F_v' = 175$ psi, Modulus of Elasticity, $E' = 1600000$ psi							
	Nominal Size of S4S Lumber							
	2 x 4	2 x 6	2 x 8	2 x 10	2 x 12	3 x 6	4 x 4	4 x 8
	F _b (psi) =							
	1500	1250	1200	1050	975	1250	1500	1200
100	58	91	112	135	156	104	77	139
200	46	69	89	113	113	86	61	117
300	39	56	73	94	111	73	54	105
400	34	9	63	82	96	63	49	96
500	30	43	56	73	86	56	45	86
600	27	40	51	67	78	51	42	79
700	25	37	47	62	72	47	39	73
800	24	34	44	58	68	44	36	68
900	22	32	42	54	64	42	34	64
1000	21	31	40	51	60	40	33	61
1200	19	28	36	47	55	36	30	55
1400	18	26	33	43	51	33	27	51
1600	17	24	31	41	48	31	26	48
1800	16	23	29	38	45	29	24	45
2000	15	21	28	36	43	28	23	43
2200	14	20	27	34	41	27	22	41
2400	13	20	25	33	39	25	21	39
2600	13	19	24	32	37	24	20	37
2800	12	18	23	31	36	23	19	36
3000	12	17	23	29	35	23	19	35

1. All values based on 2005 NDS for lumber species with the above properties
2. The following load factors have been considered in the above tables: $C_d = 1.25$, $C_{M,b} = 0.85$ (1.0 for 2 x 10 & 2 x 12), $C_{M,v} = 0.97$, $C_{M,E} = 0.9$
3. $\varnothing_{\max} = \ell/360$, but not to exceed $1/4"$
4. All values based on worst case of deflection, bending or shear
5. All values above the bold line are controlled by deflection. Bending and shear govern below.

Safe Spacing (ℓ) in Inches of Supports for Joists, Studs, etc. Continuous Over Three or More Spans

$\varnothing_{\max} = \ell/360$, but not to exceed $1/4"$

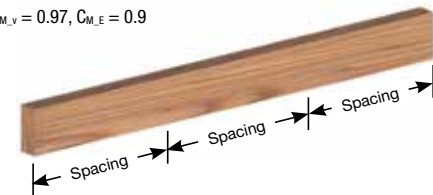

MULTI-SPAN SINGLE-PLY LEDGER								
Equivalent Uniform Load (lbs per lineal ft)	Shear Parallel to Grain, $F_v' = 175$ psi, Modulus of Elasticity, $E' = 1600000$ psi							
	Nominal Size of S4S Lumber							
	2 x 4	2 x 6	2 x 8	2 x 10	2 x 12	3 x 6	4 x 4	4 x 8
	F _b (psi) =							
	1500	1250	1200	1050	975	1250	1500	1200
100	72	107	131	158	183	121	94	163
200	54	77	100	129	152	100	76	137
300	44	63	81	105	124	81	66	123
400	38	54	70	91	107	70	58	108
500	34	49	63	82	96	63	52	96
600	31	44	57	74	87	57	47	88
700	28	41	53	69	81	53	44	81
800	27	38	50	64	76	50	41	76
900	25	36	47	61	71	47	38	72
1000	24	34	44	58	68	44	36	68
1200	22	31	40	52	62	40	33	62
1400	19	29	37	49	57	37	31	57
1600	17	27	35	45	53	35	29	54
1800	15	24	32	42	50	33	27	51
2000	14	23	30	39	48	31	26	48
2200	13	21	28	36	44	30	24	46
2400	12	20	26	34	42	28	23	44
2600	12	18	24	32	39	27	22	42
2800	11	18	23	30	34	26	22	40
3000	10	17	22	29	35	24	20	39

1. All values based on 2005 NDS for lumber species with the above properties
2. The following load factors have been considered in the above tables: $C_d = 1.25$, $C_{M,b} = 0.85$ (1.0 for 2 x 10 & 2 x 12), $C_{M,v} = 0.97$, $C_{M,E} = 0.9$
3. Multi-spans continuous over 3 spans or 4 supports
4. $\varnothing_{\max} = \ell/360$, but not to exceed $1/4"$
5. All values based on worst case of deflection, bending or shear
6. All values above the bold line are controlled by deflection. Bending and shear govern below.

PLYWOOD PRESSURE AND LOAD CHART

Form Loading in Pounds/Sq. Foot for Incremental Slab Thickness*

FORM LOADING DATA								
Concrete Weight (lbs per sq ft)	Slab Thickness							
	2 in.	4 in.	6 in.	8 in.	10 in.	12 in.	14 in.	16 in.
100	67	84	100	117	134	150	167	184
115	70	89	108	127	146	165	185	204
125	71	92	113	134	155	175	196	217
135	73	95	118	140	163	185	208	230
150	75	100	125	150	175	200	225	250
160	77	104	130	157	184	210	237	264

*Values above include 50 psf live load for construction loads. Formwork dead load is not included.

Safe Spacing (ℓ) in Inches of Supports for Plywood Sheathing
 Continuous Over Four or More Supports
 $\phi_{max} = \ell/360$, but not to exceed $1/16"$

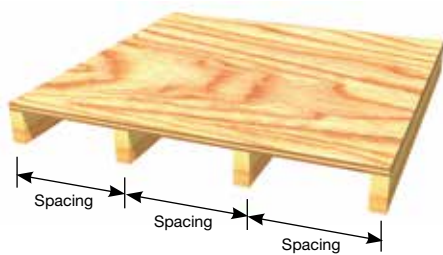

Sanded thickness, panel grain parallel to span.

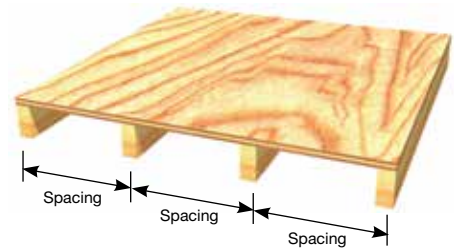

Sanded thickness, panel grain perpendicular to span.

Pressure or Load (lbs per sq ft)	TABLE BASED ON APA RATED PLYWOOD CLASS 1							
	F _s = 72 psi		F _b = 1930 psi		E _c = 1500000 psi		E = 1650000 psi	
	Sanded Thickness, Face Grain Parallel to Span				Sanded Thickness, Face Grain Perpendicular to Span			
	1/2 in.	5/8 in.	3/4 in.	1 in.	1/2 in.	5/8 in.	3/4 in.	1 in.
75	21	24	26	31	14	16	21	28
100	19	22	24	29	13	14	19	26
125	18	21	23	27	12	13	19	24
150	17	20	22	26	11	12	17	23
175	15	19	21	25	10	11	15	22
200	15	18	20	24	10	11	15	21
300	13	15	18	21	8	9	12	19
400	12	13	15	20	7	8	11	17
500	11	12	14	18	7	7	10	14
600	10	11	13	16	6	7	9	13
700	9	10	12	15	5	6	8	12
800	8	10	11	14	4	5	7	11
900	8	9	10	13	4	4	6	11
1000	7	8	10	13	3	4	5	10

BBS-54 / BBS-54L

The BBS-54 and BBS-54L Standard Steel Bridge Overhang Bracket is a classic design for the bridge industry. This state-of-the-art standard Bridge Overhang Bracket is designed for use on steel and concrete girders. Easy and quick presetting on the ground is only one of the features.

Meadow Burke also provides a longer deeper version of the BBS-54, the BBS-54L. The increased vertical and diagonal dimension allows for better load transfer on deep structural beams. This allows the transferred load to be closer to the bottom flange.

To Order:
Specify quantity, type and name.

Example:
350 pcs., BBS-54 Bridge Overhang Bracket.

BBS-27 BRIDGE OVERHANG BRACKET

The BBS-27 Steel Bridge Overhang Bracket is now available. Like the BBS-54, this bracket is perfectly designed to accommodate beams as shallow as 30". This small bracket is designed for even the biggest jobs. The BBS-27 minimizes material cost and installation time. The 27" Top Chord is ideal for small overhangs.

To Order:
Specify quantity, type and name.

Example:
350 pcs., BBS-27 Bridge Overhang Bracket.

BBS-C CONVERSION KIT

The Meadow-Burke Bridge Overhang Bracket conversion Kit consists of a longer vertical bottom leg and diagonal bottom leg only. The conversion kit will allow you to extend your existing standard BBS-54 Bridge Overhang Bracket to 50" and 70" long (deep) bracket.

To Order:
Specify quantity, type and name.

Example:
350 pcs., BBS-C Conversion Kit.



WARNING:

- Do not exceed safe work load of this product.
- Brackets should be adjusted properly during the normal "dry run" operation.
- Do not attempt an upward adjustment during the concrete pouring operation.
- Do not lower bracket adjustment during the concrete pour.

BBS-27, BBS-54 & BBS-54L BRIDGE OVERHANG BRACKET

SPECIFICATIONS	BBS-27	BBS-54	BBS-54L
Top Chord Length	27"	54"	54"
Min/Max Vertical	17" - 28"	28" - 48"	47" - 67"
Min/Max Diagonal	24" - 37"	45" - 67"	62" - 83"
Top Chord Slopes w/ Bridge Deck Slope	No	No	No
Total Weight	28 lbs.	49 lbs.	54 lbs.
Yield Strength	50,000 psi	50,000 psi	50,000 psi
Maximum Vertical Load	4,500 lbs.	4,500 lbs.	4,500 lbs.
Maximum Diagonal Load	3,750 lbs.	3,750 lbs.	3,750 lbs.

1. Working Loads are based on a 2:1 safety factor against failure.
2. Contact Meadow Burke Engineering Department for design assistance.

BBS-54 / BBS-54L

When supported by a bridge hanger, the Meadow Burke Overhang Bracket becomes a statically indeterminate structure. Subsequently, extensive physical testing is required to obtain performance data. Law Engineering of Atlanta, GA has performed and certified testing as illustrated and described below.

Three equal hydraulic rams, positioned as shown, applied equal "L" loads (pounds) to the horizontal beam while measurements were taken of hanger load, horizontal beam stress, tip deflection, diagonal leg load and vertical leg load. This loading induced a moment load about the supported end of the bracket equal to 8.25 "L" (foot-pounds).

All tests were run within the expected hanger safe working load range to a maximum of 6,000 pounds, but not beyond the known yield strengths of the three structural members of the bridge overhang bracket.

There are 5 potential "H" hanger locations and 5 nominal "V" positions. Of these 25 cases, 19 were performed. In all cases every parameter measured produced excellent straight line correlations. This permitted the development of empirical equations suitable for design, which related the applied load to the capacity of the bridge overhang bracket. Some general observations of the test results are as follows:

Some general observations of the test results are as follows:

- The relationship between the applied moment load and the induced hanger load increased as the "H" hanger position moved from 17-1/8" to 7-1/8", but was constant for any "V" dimension tested at any individual "H" position.
- The relationships between the applied moment load and the induced values for hanger load, horizontal beam stress, tip deflection and leg loads all varied as functions of both the "H" dimension and the "V" dimension.

Statistically, all of the parameters were evaluated and correlated. Two "standard deviations" were unfavorably added to or subtracted from the recorded data. This was done to assure that all other bridge overhang brackets manufactured to the same specifications would perform within the ranges determined. The empirical equations which have been derived defined the performance of each of the measured parameters for all "H" positions and for all "V" dimensions.

SPACING TABLES

The spacing tables on the following pages indicate the maximum overhang bracket spacings for various slab thicknesses and screed loads based upon the capacity of the bracket. Note that the lumber formwork must be checked for the selected bracket spacing. It is also important to keep in mind that the tables are based upon the screed load per bracket, not the load on a single screed wheel. When the spacing of the screed wheels is less than the selected bracket spacing, the screed wheel load must be increased to account for the fact that a single bracket will carry the load of more than one screed wheel. This requires some trial and error, but in most cases multiplying the screed wheel load by a properly selected spacing factor will give good results with one iteration.

Using the tables involves a few straight forward steps. First determine the overhang width and type of beam or girder, then select the table that matches that condition. Next, determine the slab thickness of the overhang, the vertical "V" dimension of the bracket, the safe working load (SWL) of the hanger, and the screed wheel load per bracket. A bracket spacing can be determined by entering the table with these four values. If the spacing of the screed wheels is less than the selected bracket spacing, the screed wheel load must be increased as described on the following page. Normally, the larger the "V" dimension, the wider the bracket spacing can be. It is typically practical to select a hanger that gives an overhang bracket spacing of 24" to 48" when possible. The spacings shown in the tables are intended to be used as a general guide. Contact Meadow Burke Engineering for recommended spacings when conditions differ from the tables provided (use form on page 65).

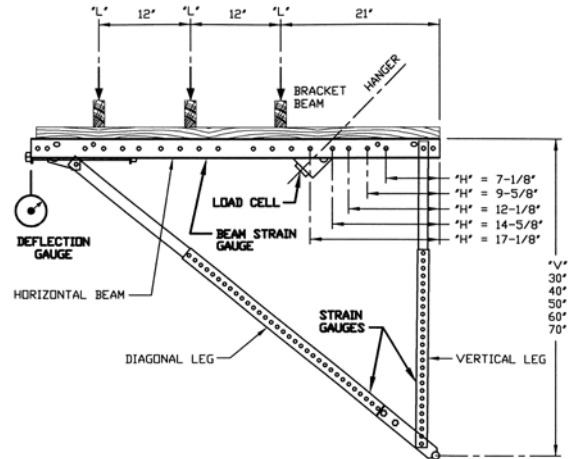

SCREED WHEEL LOAD PER BRACKET

Determining the actual screed wheel load per bracket is important. If the spacing selected using the load of one screed wheel is greater than the screed wheel spacing, the screed wheel load must be increased to account for the fact that a single bracket will carry the load of more than one screed wheel. The two types of bridge deck finishing machines normally used are the 4 wheel and the 8 wheel. This represents the total number of wheels. The wheels on one screed running rail are one-half the total number, as shown below.

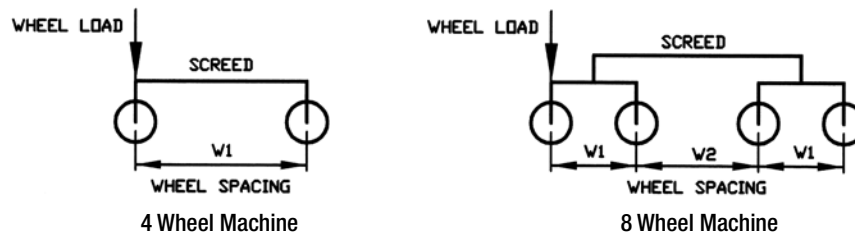

When selecting a hanger spacing using the unfactored screed wheel load, and the ratio S / W of the selected bracket spacing “S” to the screed wheel spacing “W” is:

- Equal to or less than 1.0, than use the bracket spacing selected;
- Greater than 1.0 and up to 1.5, multiply the screed wheel load by a factor of 1.25 and re-enter the tables;
- Greater than 1.5 and up to 2.5, multiply the screed wheel load by a factor of 1.50 and re-enter the tables;
- Greater than 2.5, multiply the screed wheel load by a factor of 1.75 and re-enter the tables.

EXAMPLE USING THE SPACING TABLES

To get a better feel for using the spacing tables, use the following example:

- Type II concrete beam
- 3'-0" slab overhang
- 8" slab thickness
- Bracket “V” dimension of approximately 30"
- Hanger with a 3,000 pound safe working load
- Screed machine with a total operating weight of 7,250 pounds
- 4 wheels each side
- Wheel spacings of 2'-0", 3'-9" and 2'-0"

The spacing table for concrete beams with over 2'-0" to 3'-0" overhangs can be used.

The screed wheel load needs to be determined. The manufacturer of the bridge deck finishing machine can provide the total operating weight of the screed machine, as well as the maximum screed wheel load. The weights of parts of the screed machine, such as the screed augers and operators station, are not equally balanced between the screed running rails. Because of this, the total operating weight divided by total number of screed wheels is less than the maximum screed wheel load. This difference is a maximum factor between 1.33 and 1.45 in most cases. For this example, the maximum screed wheel load has not been provided, so it can be estimated as $1.45 \times 7,250 / 8 = 1,314$ pounds. Round this value up to 1,500 pounds for use in the spacing tables.

Entering the spacing table with an 8" slab, a “V” of 30" and a screed load of 1,500 pounds, a spacing of 4'-9" is indicated for a hanger with a 3,000 pound safe working load. The ratio of S / W is $4.75 / 2 = 2.375$, so we need to multiply the screed wheel load by a factor of 1.5 to account for the fact that the selected bracket spacing is greater than the screed wheel spacing. We re-enter the table with an estimate of $1.5 \times 1,314 = 1,971$ pounds, which can be rounded up to 2,000 pounds. This indicates a spacing of 3'-3". We can check the actual screed wheel factor, which is $1 + (S - W) / S$ or $1 + (3.25 - 2) / 3.25 = 1.38$ versus the estimated 1.5, so using a 3'-3" spacing is a good guide value.

Contact Meadow Burke Engineering for recommended spacings when conditions differ from the tables provided (use form on page 65).

BBS-54 BRIDGE OVERHANG BRACKET

1' 0" < OVERHANG ≤ 2' 0" STEEL BEAM H = 14-5/8"

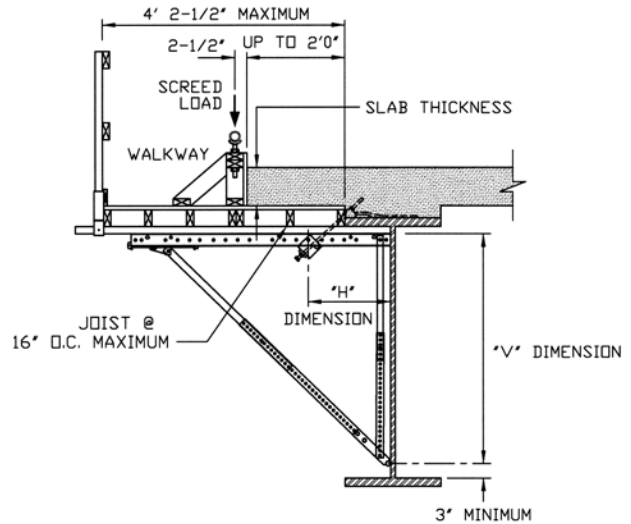

BBS-54 BRIDGE OVERHANG BRACKET

Slab Thickness (in.)	Bracket "V" Dimension (in.)	Screed Load Per Bracket (pounds)							Hanger SWL (pounds)
		0	1000	1250	1500	1750	2000	2250	
		Bracket Spacing							
6	30	5' - 6" 8' - 0"	3' - 0" 8' - 0"	2' - 9" 8' - 0"	2' - 0" 7' - 6"	1' - 3" 7' - 0"	- 6' - 6"	- 6' - 0"	3000 6000
	40	5' - 6" 8' - 0"	3' - 0" 8' - 0"	2' - 9" 8' - 0"	2' - 0" 7' - 6"	1' - 3" 7' - 0"	- 6' - 6"	- 6' - 0"	3000 6000
	50	5' - 6" 8' - 0"	3' - 0" 8' - 0"	2' - 9" 8' - 0"	2' - 0" 7' - 6"	1' - 3" 7' - 0"	- 6' - 6"	- 6' - 0"	3000 6000
8	30	5' - 0" 8' - 0"	2' - 9" 8' - 0"	2' - 6" 7' - 3"	1' - 9" 6' - 9"	- 6' - 6"	- 6' - 0"	- 5' - 6"	3000 6000
	40	5' - 0" 8' - 0"	2' - 9" 8' - 0"	2' - 6" 7' - 3"	1' - 9" 6' - 9"	- 6' - 6"	- 6' - 0"	- 5' - 6"	3000 6000
	50	5' - 0" 8' - 0"	2' - 9" 8' - 0"	2' - 6" 7' - 3"	1' - 9" 6' - 9"	- 6' - 6"	- 6' - 0"	- 5' - 6"	3000 6000
10	30	4' - 6" 8' - 0"	2' - 6" 7' - 6"	2' - 3" 7' - 0"	1' - 6" 6' - 6"	- 6' - 0"	- 5' - 6"	- 5' - 0"	3000 6000
	40	4' - 6" 8' - 0"	2' - 6" 7' - 6"	2' - 3" 7' - 0"	1' - 6" 6' - 6"	- 6' - 0"	- 5' - 6"	- 5' - 0"	3000 6000
	50	4' - 6" 8' - 0"	2' - 6" 7' - 6"	2' - 3" 7' - 0"	1' - 6" 6' - 6"	- 6' - 0"	- 5' - 6"	- 5' - 0"	3000 6000
12	30	4' - 0" 8' - 0"	2' - 3" 7' - 0"	1' - 9" 6' - 6"	- 6' - 0"	- 5' - 6"	- 5' - 0"	- 4' - 6"	3000 6000
	40	4' - 0" 8' - 0"	2' - 3" 7' - 0"	1' - 9" 6' - 6"	- 6' - 0"	- 5' - 6"	- 5' - 0"	- 4' - 6"	3000 6000
	50	4' - 0" 8' - 0"	2' - 3" 7' - 0"	1' - 9" 6' - 6"	- 6' - 0"	- 5' - 6"	- 5' - 0"	- 4' - 6"	3000 6000

- NOTE:**
- Design Load Calculations for the above bracket spacings are based on a dead load of 160 pcf for concrete and formwork, a live load of 50 psf for workers, moveable equipment and materials, and an additional 75 plf vertical load applied to the outside edge of the deck overhang when no screed is present. A 60 psf LL/DL is also applied to the walkway area.
 - A 200 lbs point load was considered in the above tables for the guardrail system.
 - Above spacing's only apply to bracket, lumber was not considered part of the design.

BBS-54 BRIDGE OVERHANG BRACKET

2' 0" < OVERHANG ≤ 3' 0" STEEL BEAM H = 14-5/8"

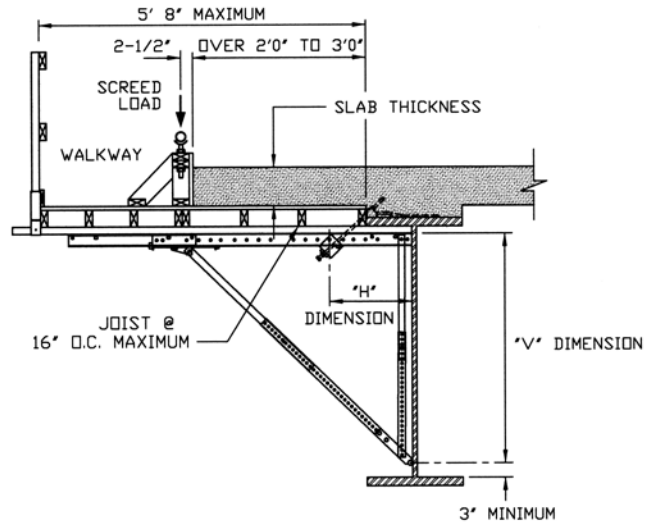
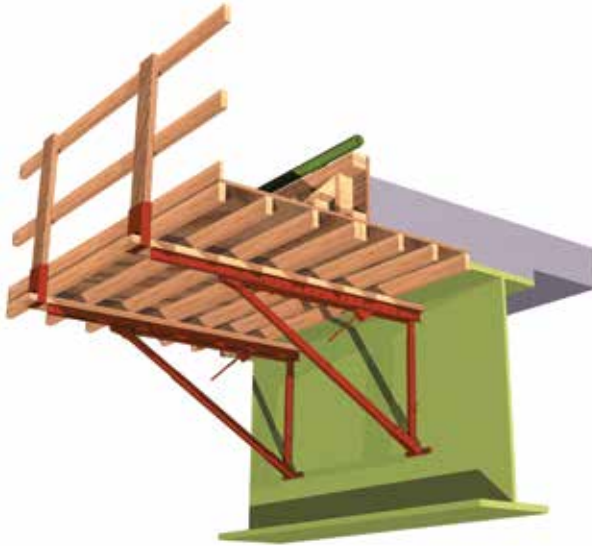

BBS-54 BRIDGE OVERHANG BRACKET

Slab Thickness (in.)	Bracket "V" Dimension (in.)	Screed Load Per Bracket (pounds)							Hanger SWL (pounds)
		0	1000	1250	1500	1750	2000	2250	
		Bracket Spacing							
6	30	4' - 0" 8' - 0"	2' - 0" 6' - 0"	1' - 6" 5' - 6"	- 5' - 0"	- 4' - 6"	- 4' - 3"	- 3' - 9"	3000 6000
	40	4' - 0" 8' - 0"	2' - 0" 6' - 0"	1' - 6" 5' - 6"	1' - 0" 5' - 0"	- 4' - 6"	- 4' - 3"	- 3' - 9"	3000 6000
	50	4' - 0" 8' - 0"	2' - 0" 6' - 0"	1' - 6" 5' - 6"	1' - 0" 5' - 0"	- 4' - 6"	- 4' - 3"	- 3' - 9"	3000 6000
8	30	3' - 6" 7' - 0"	1' - 9" 5' - 3"	- 5' - 0"	- 4' - 6"	- 4' - 0"	- 3' - 9"	- 3' - 3"	3000 6000
	40	3' - 6" 7' - 0"	1' - 9" 5' - 3"	1' - 3" 5' - 0"	- 4' - 6"	- 4' - 0"	- 3' - 9"	- 3' - 3"	3000 6000
	50	3' - 6" 7' - 0"	1' - 9" 5' - 3"	1' - 3" 5' - 0"	1' - 0" 4' - 6"	- 4' - 0"	- 3' - 9"	- 3' - 3"	3000 6000
10	30	3' - 0" 6' - 3"	1' - 6" 4' - 9"	- 4' - 6"	- 4' - 0"	- 3' - 9"	- 3' - 6"	- 3' - 0"	3000 6000
	40	3' - 0" 6' - 3"	1' - 6" 4' - 9"	- 4' - 6"	- 4' - 0"	- 3' - 9"	- 3' - 6"	- 3' - 0"	3000 6000
	50	3' - 0" 6' - 3"	1' - 6" 4' - 9"	- 4' - 6"	- 4' - 0"	- 3' - 9"	- 3' - 6"	- 3' - 0"	3000 6000
12	30	2' - 9" 5' - 9"	1' - 6" 4' - 3"	- 4' - 0"	- 3' - 9"	- 3' - 3"	- 3' - 0"	- 2' - 6"	3000 6000
	40	2' - 9" 5' - 9"	1' - 6" 4' - 3"	- 4' - 0"	- 3' - 9"	- 3' - 3"	- 3' - 0"	- 2' - 6"	3000 6000
	50	2' - 9" 5' - 9"	1' - 6" 4' - 3"	- 4' - 0"	- 3' - 9"	- 3' - 3"	- 3' - 0"	- 2' - 6"	3000 6000

- NOTE:**
- Design Load Calculations for the above bracket spacings are based on a dead load of 160 pcf for concrete and formwork, a live load of 50 psf for workers, moveable equipment and materials, and an additional 75 plf vertical load applied to the outside edge of the deck overhang when no screed is present. A 60 psf LL/DL is also applied to the walkway area.
 - A 200 lbs point load was considered in the above tables for the guardrail system.
 - Above spacing's only apply to bracket, lumber was not considered part of the design.

BBS-54 BRIDGE OVERHANG BRACKET

3' 0" < OVERHANG ≤ 4' 0" STEEL BEAM H = 14-5/8"

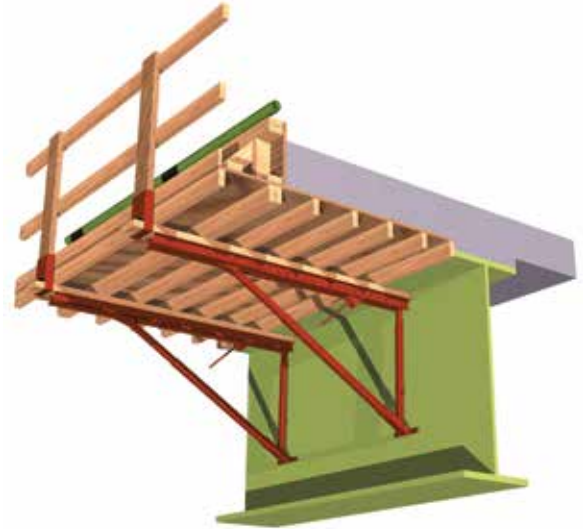
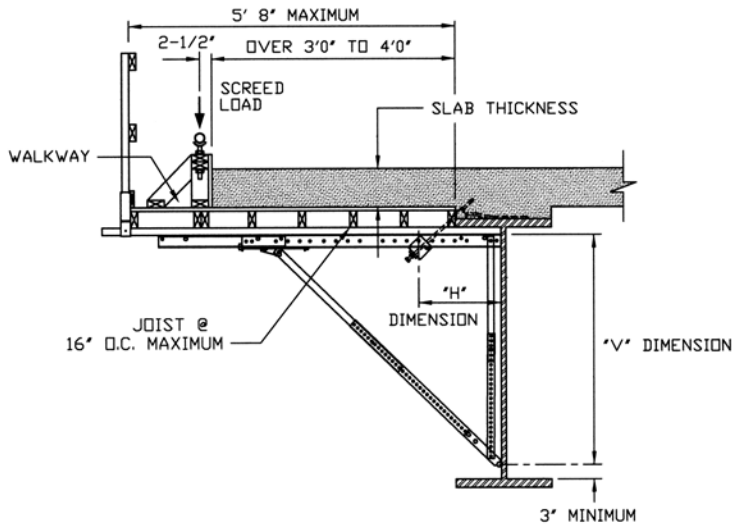

BBS-54 BRIDGE OVERHANG BRACKET									
Slab Thickness (in.)	Bracket "V" Dimension (in.)	Screed Load Per Bracket (pounds)							Hanger SWL (pounds)
		0	1000	1250	1500	1750	2000	2250	
		Bracket Spacing							
6	30	3' - 6"	2' - 0"	-	-	-	-	-	3000 6000
	40	7' - 0"	4' - 9"	4' - 3"	3' - 6"	2' - 9"	2' - 0"	1' - 6"	3000 6000
	50	7' - 0"	5' - 6"	5' - 0"	4' - 3"	3' - 9"	3' - 0"	2' - 3"	3000 6000
8	30	3' - 0"	1' - 6"	-	-	-	-	-	3000 6000
	40	6' - 0"	4' - 6"	4' - 0"	3' - 3"	2' - 6"	1' - 9"	-	3000 6000
	50	6' - 0"	4' - 9"	4' - 3"	3' - 6"	3' - 0"	2' - 3"	-	3000 6000
10	30	3' - 0"	1' - 6"	-	-	-	-	-	3000 6000
	40	6' - 3"	4' - 9"	4' - 3"	4' - 3"	3' - 9"	3' - 0"	-	3000 6000
	50	2' - 6"	-	-	-	-	-	-	3000 6000
12	30	2' - 6"	4' - 0"	3' - 6"	3' - 0"	2' - 3"	1' - 6"	-	3000 6000
	40	2' - 6"	-	-	-	-	-	-	3000 6000
	50	5' - 3"	4' - 0"	3' - 6"	3' - 0"	2' - 3"	1' - 6"	-	3000 6000
12	30	2' - 6"	-	-	-	-	-	-	3000 6000
	40	5' - 3"	4' - 6"	4' - 0"	3' - 3"	2' - 6"	1' - 9"	-	3000 6000
	50	2' - 3"	-	-	-	-	-	-	3000 6000
12	30	4' - 9"	3' - 6"	3' - 3"	2' - 9"	2' - 0"	1' - 3"	-	3000 6000
	40	2' - 3"	-	-	-	-	-	-	3000 6000
	50	4' - 9"	3' - 6"	3' - 3"	2' - 9"	2' - 0"	1' - 3"	-	3000 6000
12	30	2' - 3"	-	-	-	-	-	-	3000 6000
	40	5' - 0"	3' - 9"	3' - 6"	3' - 0"	2' - 3"	1' - 6"	-	3000 6000
	50	2' - 3"	-	-	-	-	-	-	3000 6000

- NOTE:**
- Design Load Calculations for the above bracket spacings are based on a dead load of 160 pcf for concrete and formwork, a live load of 50 psf for workers, moveable equipment and materials, and an additional 75 plf vertical load applied to the outside edge of the deck overhang when no screed is present. A 60 psf LL/DL is also applied to the walkway area.
 - A 200 lbs point load was considered in the above tables for the guardrail system.
 - Above spacing's only apply to bracket, lumber was not considered part of the design.

BBS-54L BRIDGE OVERHANG BRACKET

FOR USE ON DEEP STEEL GIRDERS WITH UP TO 3'-0" OVERHANG

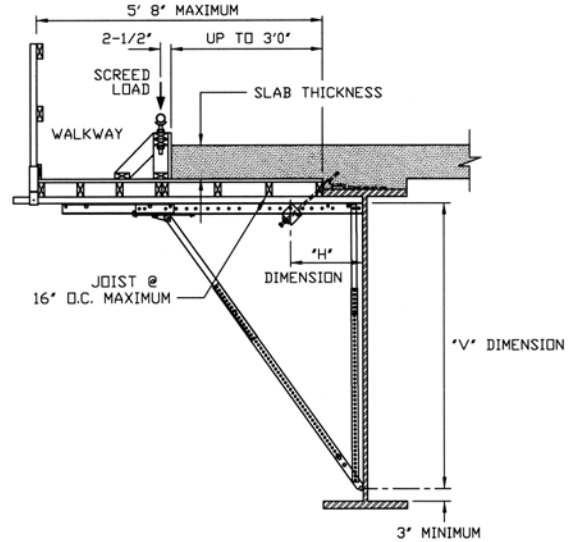

9 - 22

BBS-54L BRIDGE OVERHANG BRACKET									
Slab Thickness (in.)	Bracket "V" Dimension (in.)	Screed Load Per Bracket (pounds)							Hanger SWL (pounds)
		0	1000	1250	1500	1750	2000	2250	
		Bracket Spacing							
12	50	5' - 3"	3' - 6"	3' - 0"	2' - 6"	2' - 0"	1' - 6"	1' - 0"	3000
		5' - 9"	4' - 9"	4' - 3"	4' - 0"	3' - 9"	3' - 6"	3' - 3"	6000
	60	5' - 3"	3' - 6"	3' - 0"	2' - 6"	2' - 0"	1' - 6"	1' - 0"	3000
		5' - 9"	4' - 9"	4' - 3"	4' - 0"	3' - 9"	3' - 6"	3' - 3"	6000
	70	5' - 3"	3' - 6"	3' - 0"	2' - 6"	2' - 0"	1' - 6"	1' - 0"	3000
		5' - 9"	4' - 9"	4' - 3"	4' - 0"	3' - 9"	3' - 6"	3' - 3"	6000
10	50	5' - 9"	3' - 9"	3' - 3"	2' - 9"	2' - 3"	1' - 9"	1' - 3"	3000
		6' - 6"	5' - 3"	4' - 9"	4' - 6"	4' - 3"	3' - 9"	3' - 6"	6000
	60	5' - 9"	3' - 9"	3' - 3"	2' - 9"	2' - 3"	1' - 9"	1' - 3"	3000
		6' - 6"	5' - 3"	4' - 9"	4' - 6"	4' - 3"	3' - 9"	3' - 6"	6000
	70	5' - 9"	3' - 9"	3' - 3"	2' - 9"	2' - 3"	1' - 9"	1' - 3"	3000
		6' - 6"	5' - 3"	4' - 9"	4' - 6"	4' - 3"	3' - 9"	3' - 6"	6000
8	50	6' - 0"	4' - 0"	3' - 6"	2' - 9"	2' - 3"	1' - 9"	1' - 3"	3000
		7' - 3"	5' - 9"	5' - 3"	5' - 0"	4' - 6"	4' - 3"	4' - 0"	6000
	60	6' - 0"	4' - 0"	3' - 6"	2' - 9"	2' - 3"	1' - 9"	1' - 3"	3000
		7' - 3"	5' - 9"	5' - 3"	5' - 0"	4' - 6"	4' - 3"	4' - 0"	6000
	70	6' - 0"	4' - 0"	3' - 6"	2' - 9"	2' - 3"	1' - 9"	1' - 3"	3000
		7' - 3"	5' - 9"	5' - 3"	5' - 0"	4' - 6"	4' - 3"	4' - 0"	6000
6	50	6' - 6"	4' - 3"	3' - 9"	3' - 0"	2' - 6"	2' - 0"	1' - 3"	3000
		8' - 0"	6' - 6"	6' - 0"	5' - 6"	5' - 3"	4' - 9"	4' - 6"	6000
	60	6' - 6"	4' - 3"	3' - 9"	3' - 0"	2' - 6"	2' - 0"	1' - 3"	3000
		8' - 0"	6' - 6"	6' - 0"	5' - 6"	5' - 3"	4' - 9"	4' - 6"	6000
	70	6' - 6"	4' - 3"	3' - 9"	3' - 0"	2' - 6"	2' - 0"	1' - 3"	3000
		8' - 0"	6' - 6"	6' - 0"	5' - 6"	5' - 3"	4' - 9"	4' - 6"	6000

NOTE: Design includes 50 PSF live load on the walkway area, 150 PCF concrete weight and 75 PSF live load on the concrete area and 10 PSF formwork load on the formwork area. The spacings shown above are based on bracket capacities utilizing a bracket "H" dimension of 14-5/8". The lumber formwork must be checked for the selected spacing.

WARNING: The spacings shown are intended to be used as a general guide. The Screed Load Per Bracket value must be the screed wheel per bracket, which is greater than the weight of a single screed wheel when the bracket spacing exceeds the screed wheel spacing. Refer to the section "Screed Wheel Load Per Bracket" immediately preceding these tablets. Contact Meadow Burke Engineering for recommended spacing when conditions differ from above.

BBS-54L BRIDGE OVERHANG BRACKET

FOR USE ON DEEP STEEL GIRDERS WITH OVER 3'-0" TO 4'-0" OVERHANG

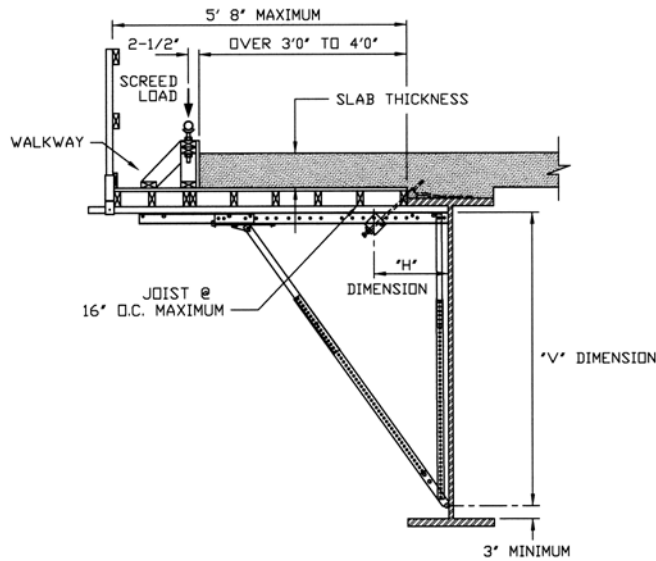

BBS-54L BRIDGE OVERHANG BRACKET									
Slab Thickness (in.)	Bracket "V" Dimension (in.)	Screed Load Per Bracket (pounds)							Hanger SWL (pounds)
		0	1000	1250	1500	1750	2000	2250	
Bracket Spacing									
12	50	4' - 0"	2' - 0"	1' - 6"	1' - 3"	-----	-----	-----	3000
		4' - 9"	3' - 9"	3' - 6"	3' - 3"	3' - 0"	2' - 6"	2' - 3"	6000
	60	4' - 0"	2' - 0"	1' - 6"	1' - 3"	-----	-----	-----	3000
		4' - 9"	3' - 9"	3' - 6"	3' - 3"	3' - 0"	2' - 9"	2' - 6"	6000
	70	4' - 0"	2' - 0"	1' - 6"	1' - 3"	-----	-----	-----	3000
		4' - 9"	3' - 9"	3' - 6"	3' - 3"	3' - 0"	2' - 9"	2' - 6"	6000
10	50	4' - 3"	2' - 3"	1' - 9"	1' - 3"	-----	-----	-----	3000
		5' - 3"	4' - 3"	4' - 0"	3' - 9"	3' - 3"	2' - 9"	2' - 3"	6000
	60	4' - 3"	2' - 3"	1' - 9"	1' - 3"	-----	-----	-----	3000
		5' - 3"	4' - 3"	4' - 0"	3' - 9"	3' - 6"	3' - 3"	3' - 0"	6000
	70	4' - 3"	2' - 3"	1' - 9"	1' - 3"	-----	-----	-----	3000
		5' - 3"	4' - 3"	4' - 0"	3' - 9"	3' - 6"	3' - 3"	3' - 0"	6000
8	50	4' - 9"	2' - 6"	2' - 0"	1' - 6"	1' - 0"	-----	-----	3000
		6' - 0"	4' - 9"	4' - 6"	4' - 3"	3' - 9"	3' - 3"	2' - 6"	6000
	60	4' - 9"	2' - 6"	2' - 0"	1' - 6"	1' - 0"	-----	-----	3000
		6' - 0"	4' - 9"	4' - 6"	4' - 3"	4' - 0"	3' - 6"	3' - 3"	6000
	70	4' - 9"	2' - 6"	2' - 0"	1' - 6"	1' - 0"	-----	-----	3000
		6' - 0"	4' - 9"	4' - 6"	4' - 3"	4' - 0"	3' - 6"	3' - 3"	6000
6	50	5' - 3"	2' - 9"	2' - 3"	1' - 6"	1' - 0"	-----	-----	3000
		7' - 0"	5' - 6"	5' - 3"	4' - 9"	4' - 3"	3' - 6"	3' - 0"	6000
	60	5' - 3"	2' - 9"	2' - 3"	1' - 6"	1' - 0"	-----	-----	3000
		7' - 0"	5' - 6"	5' - 3"	4' - 9"	4' - 6"	4' - 0"	3' - 9"	6000
	70	5' - 3"	2' - 9"	2' - 3"	1' - 6"	1' - 0"	-----	-----	3000
		7' - 0"	5' - 6"	5' - 3"	4' - 9"	4' - 6"	4' - 0"	3' - 9"	6000

NOTE: Design includes 50 PSF live load on the walkway area, 150 PCF concrete weight and 75 PSF live load on the concrete area and 10 PSF formwork load on the formwork area. The spacings shown above are based on bracket capacities utilizing a bracket "H" dimension of 14-5/8". The lumber formwork must be checked for the selected spacing.

WARNING: The spacings shown are intended to be used as a general guide. The Screed Load Per Bracket value must be the screed wheel per bracket, which is greater than the weight of a single screed wheel when the bracket spacing exceeds the screed wheel spacing. Refer to the section "Screed Wheel Load Per Bracket" immediately preceding these tablets. Contact Meadow Burke Engineering for recommended spacing when conditions differ from above.

BBS-54 BRIDGE OVERHANG BRACKET

1' 0" < OVERHANG ≤ 2' 0" CONCRETE BEAM H = 7 ¾"

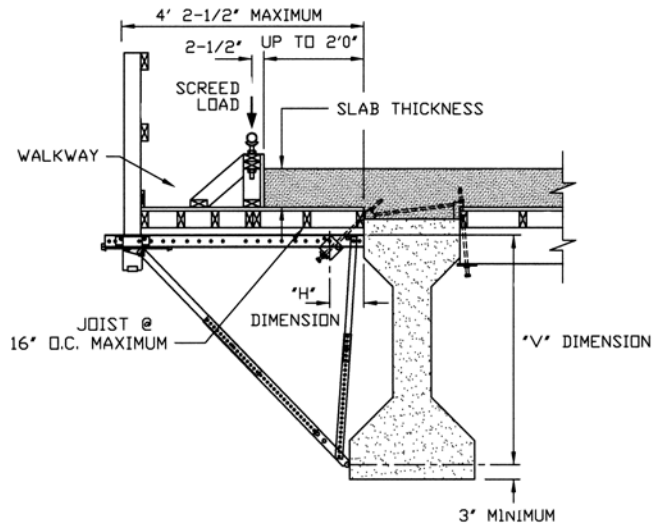

9 - 22

BBS-54 BRIDGE OVERHANG BRACKET									
Slab Thickness (in.)	Bracket "V" Dimension (in.)	Screed Load Per Bracket (pounds)							Hanger SWL (pounds)
		0	1000	1250	1500	1750	2000	2250	
		Bracket Spacing							
6	30	4' - 6" 8' - 0"	3' - 0" 7' - 6"	2' - 6" 7' - 0"	2' - 0" 6' - 6"	- 6' - 0"	- 5' - 3"	- 4' - 9"	3000 6000
	40	4' - 6" 8' - 0"	3' - 0" 7' - 6"	2' - 6" 7' - 0"	2' - 0" 6' - 6"	- 6' - 0"	- 5' - 3"	- 4' - 9"	3000 6000
	50	4' - 6" 8' - 0"	3' - 0" 7' - 6"	2' - 6" 7' - 0"	2' - 0" 6' - 6"	- 6' - 0"	- 5' - 3"	- 4' - 9"	3000 6000
8	30	4' - 0" 8' - 0"	2' - 6" 7' - 0"	2' - 0" 6' - 6"	- 6' - 0"	- 5' - 6"	- 4' - 9"	- 4' - 3"	3000 6000
	40	4' - 0" 8' - 0"	2' - 6" 7' - 0"	2' - 0" 6' - 6"	- 6' - 0"	- 5' - 6"	- 4' - 9"	- 4' - 3"	3000 6000
	50	4' - 0" 8' - 0"	2' - 6" 7' - 0"	2' - 0" 6' - 6"	- 6' - 0"	- 5' - 6"	- 4' - 9"	- 4' - 3"	3000 6000
10	30	3' - 6" 7' - 9"	2' - 0" 6' - 6"	- 6' - 0"	- 5' - 6"	- 4' - 9"	- 4' - 3"	- 3' - 9"	3000 6000
	40	3' - 6" 7' - 9"	2' - 0" 6' - 6"	- 6' - 0"	- 5' - 6"	- 4' - 9"	- 4' - 3"	- 3' - 9"	3000 6000
	50	3' - 6" 7' - 9"	2' - 0" 6' - 6"	- 6' - 0"	- 5' - 6"	- 4' - 9"	- 4' - 3"	- 3' - 9"	3000 6000
12	30	3' - 0" 7' - 0"	- 6' - 0"	- 5' - 6"	- 5' - 0"	- 4' - 3"	- 3' - 9"	- 3' - 3"	3000 6000
	40	3' - 0" 7' - 0"	- 6' - 0"	- 5' - 6"	- 5' - 0"	- 4' - 3"	- 3' - 9"	- 3' - 3"	3000 6000
	50	3' - 0" 7' - 0"	- 6' - 0"	- 5' - 6"	- 5' - 0"	- 4' - 3"	- 3' - 9"	- 3' - 3"	3000 6000

NOTE: 1. Design Load Calculations for the above bracket spacings are based on a dead load of 160 pcf for concrete and formwork, a live load of 50 psf for workers, moveable equipment and materials, and an additional 75 plf vertical load applied to the outside edge of the deck overhang when no screed is present. A 60 psf LL/DL is also applied to the walkway area.
 2. A 200 lbs point load was considered in the above tables for the guardrail system.
 3. Above spacing's only apply to bracket, lumber was not considered part of the design.

BBS-54 BRIDGE OVERHANG BRACKET

2' 0" < OVERHANG ≤ 3' 0" CONCRETE BEAM H = 7-¾"

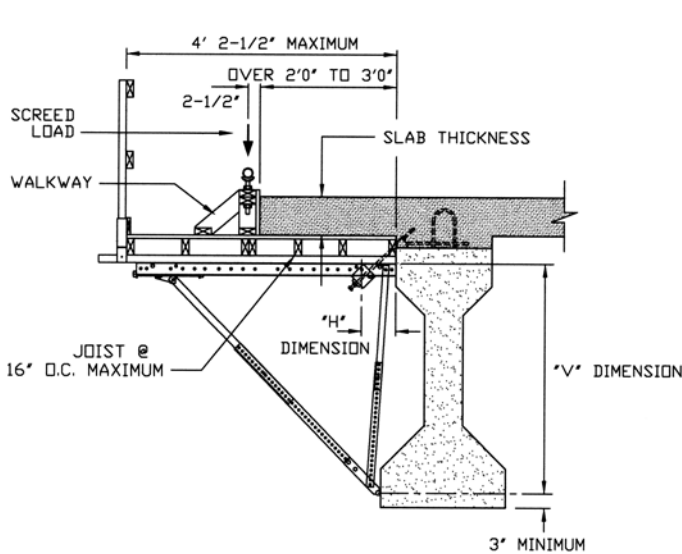

BBS-54 BRIDGE OVERHANG BRACKET									
Slab Thickness (in.)	Bracket "V" Dimension (in.)	Screed Load Per Bracket (pounds)							Hanger SWL (pounds)
		0	1000	1250	1500	1750	2000	2250	
		Bracket Spacing							
6	30	2' - 9" 6' - 0"	- 6' - 0"	- 3' - 9"	- 3' - 3"	- 2' - 6"	- 2' - 0"	- -	3000 6000
	40	3' - 3" 6' - 9"	3' - 3" 6' - 9"	- 4' - 6"	- 4' - 0"	- 3' - 6"	- 3' - 0"	- 2' - 0"	3000 6000
	50	3' - 9" 7' - 6"	3' - 9" 7' - 6"	- 5' - 6"	- 5' - 0"	- 4' - 6"	- 4' - 0"	- 3' - 6"	3000 6000
8	30	2' - 6" 5' - 3"	- 5' - 3"	- 3' - 3"	- 2' - 6"	- 2' - 0"	- -	- -	3000 6000
	40	2' - 6" 6' - 3"	- 6' - 3"	- 4' - 0"	- 3' - 6"	- 3' - 0"	- 2' - 6"	- 2' - 0"	3000 6000
	50	3' - 3" 6' - 9"	- 6' - 9"	- 4' - 9"	- 4' - 3"	- 3' - 9"	- 3' - 3"	- 2' - 9"	3000 6000
10	30	2' - 0" 4' - 6"	- 4' - 6"	- 2' - 6"	- 2' - 0"	- -	- -	- -	3000 6000
	40	2' - 3" 4' - 6"	- 4' - 6"	- 3' - 3"	- 2' - 9"	- 2' - 3"	- -	- -	3000 6000
	50	2' - 9" 6' - 0"	- 6' - 0"	- 4' - 0"	- 3' - 6"	- 3' - 0"	- 2' - 6"	- 2' - 0"	3000 6000
12	30	- 3' - 9"	- 3' - 9"	- -	- -	- -	- -	- -	3000 6000
	40	- 4' - 6"	- 4' - 6"	- 2' - 6"	- -	- -	- -	- -	3000 6000
	50	2' - 6" 5' - 3"	- 5' - 3"	- 3' - 3"	- 2' - 9"	- 2' - 0"	- 2' - 0"	- -	3000 6000

- NOTE:**
- Design Load Calculations for the above bracket spacings are based on a dead load of 160 pcf for concrete and formwork, a live load of 50 psf for workers, moveable equipment and materials, and an additional 75 plf vertical load applied to the outside edge of the deck overhang when no screed is present. A 60 psf LL/DL is also applied to the walkway area.
 - A 200 lbs point load was considered in the above tables for the guardrail system.
 - Above spacing's only apply to bracket, lumber was not considered part of the design.

BBS-54L BRIDGE OVERHANG BRACKET

2'-0" < OVERHANG ≤ 3'-0" CONCRETE BEAM H = 7-3/4"

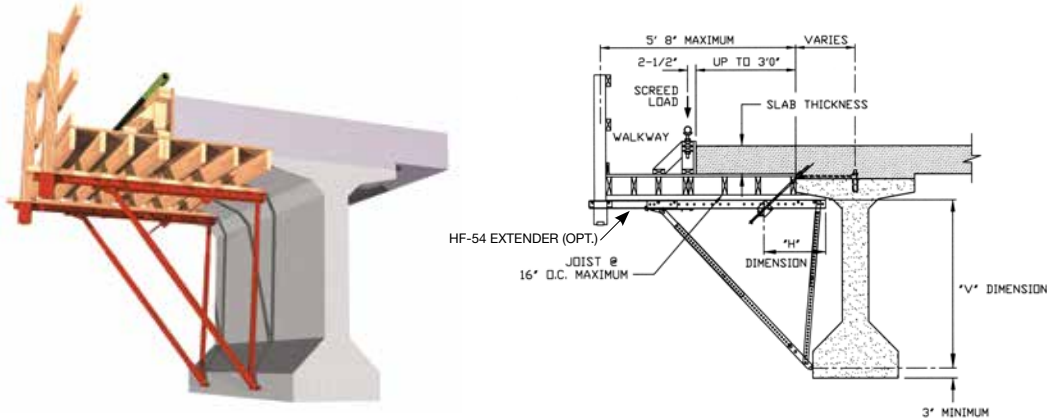

BBS-54L BRIDGE OVERHANG BRACKET									
Slab Thickness (in.)	Bracket "V" Dimension (in.)	Screed Load Per Bracket (pounds)							Hanger SWL (pounds)
		0	1000	1250	1500	1750	2000	2250	
		Bracket Spacing							
6	50	3'-9"	2'-3"	-	-	-	-	-	3000
		7'-6"	6'-0"	5'-6"	5'-0"	4'-6"	4'-0"	3'-6"	6000
	60	3'-9"	2'-3"	-	-	-	-	-	3000
		7'-6"	6'-0"	5'-6"	5'-0"	4'-6"	4'-0"	3'-6"	6000
	70	3'-9"	2'-3"	-	-	-	-	-	3000
		7'-6"	6'-0"	5'-6"	5'-0"	4'-6"	4'-0"	3'-6"	6000
8	50	3'-3"	2'-0"	-	-	-	-	-	3000
		6'-9"	5'-3"	4'-9"	4'-3"	3'-9"	3'-3"	2'-9"	6000
	60	3'-3"	2'-0"	-	-	-	-	-	3000
		6'-9"	5'-3"	4'-9"	4'-3"	3'-9"	3'-3"	2'-9"	6000
	70	3'-3"	2'-0"	-	-	-	-	-	3000
		6'-9"	5'-3"	4'-9"	4'-3"	3'-9"	3'-3"	2'-9"	6000
10	50	2'-9"	-	-	-	-	-	-	3000
		6'-0"	4'-6"	4'-0"	3'-6"	3'-0"	2'-6"	2'-0"	6000
	60	2'-9"	-	-	-	-	-	-	3000
		6'-0"	4'-6"	4'-0"	3'-6"	3'-0"	2'-6"	2'-0"	6000
	70	2'-9"	-	-	-	-	-	-	3000
		6'-0"	4'-6"	4'-0"	3'-6"	3'-0"	2'-6"	2'-0"	6000
12	50	2'-6"	-	-	-	-	-	-	3000
		5'-3"	3'-9"	3'-3"	2'-9"	2'-0"	-	-	6000
	60	2'-6"	-	-	-	-	-	-	3000
		5'-3"	3'-9"	3'-3"	2'-9"	2'-0"	-	-	6000
	70	2'-6"	-	-	-	-	-	-	3000
		5'-3"	3'-9"	3'-3"	2'-9"	2'-0"	-	-	6000

- NOTE:**
- Design Load Calculations for the above bracket spacings are based on a dead load of 160 pcf for concrete and formwork, a live load of 50 psf for workers, moveable equipment and materials, and an additional 75 pcf vertical load applied to the outside edge of the deck overhang when no screed is present. A 60 psf LL/DL is also applied to the walkway area.
 - A 200 lbs point load was considered in the above tables for the guardrail system.
 - Above spacing's only apply to bracket, lumber was not considered part of the design.

BBS-2X4 GUARDRAIL RECEPTACLE

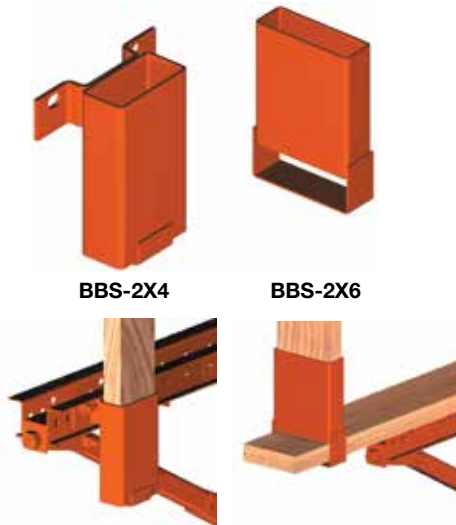

The guardrail receptacles are available to provide a guardrail post on the bridge overhang bracket, with or without an extender. Each receptacle accepts a standard 2x4 or 2x6 post and has a built-in bottom support-stop for the post. Guardrails should always be present on elevated bridge projects to comply with safety requirements.

- The BBS-2x4 receptacles can be firmly bolted to the top channel of the bridge overhang bracket with bolt holes provided in the B.O.B. Mounting hardware provided with each BBS-2x4 guard rail receptacle includes two (2) bolts and two (2) nuts.
- The BBS-2x6 receptacle slides onto the end of the flat 2x6 top runner, which is nailed to the B.O.B. channel, and is nailed on each side of the 2x6.

BBS-EXTENDER

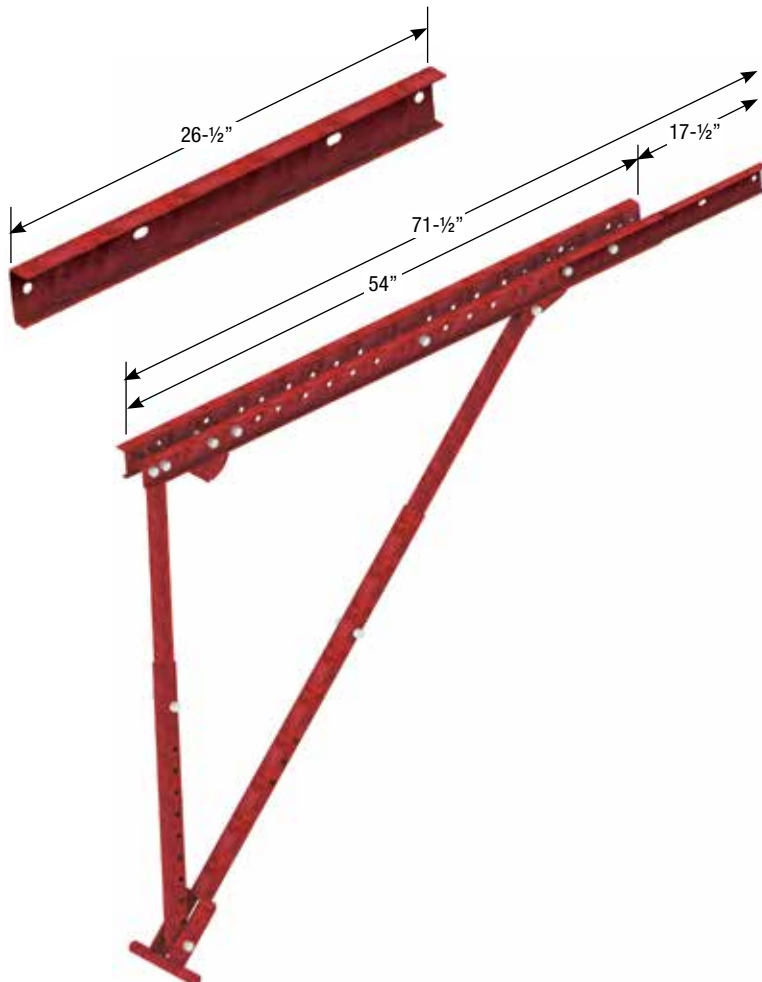

The Meadow Burke BBS-Extender is a single channel 26-1/2" long that can be bolted to the end of the BBS-54, BBS-54L & BBS-27 Bridge Overhang Brackets. The Extender allows for 17-1/2" of additional length frequently necessary to accommodate a walkway outside the screed rail. If the screed rail is near the outboard end of the horizontal member, then Meadow-Burke recommends using two (double) Extenders, side by side, and bolted to each side of the standard horizontal member. Bolts, nuts, washers and spacers are necessary to properly install double BBS-Extenders.

WARNING:

- Bridge Overhang Bracket with BBS-Extender(s) must be securely blocked to prevent outward and downward rotation of the bracket when used with a concrete beam.
- Brackets should be adjusted properly during the normal "dry run" operation.
- Do not attempt an upward adjustment during the concrete pouring operation.
- Do not lower bracket adjustment during the concrete pour.

To Order:

Specify quantity, item number and name.

Example:

350 pcs., 2x4 Extender.

BBS-WALL PLATE ASSEMBLY

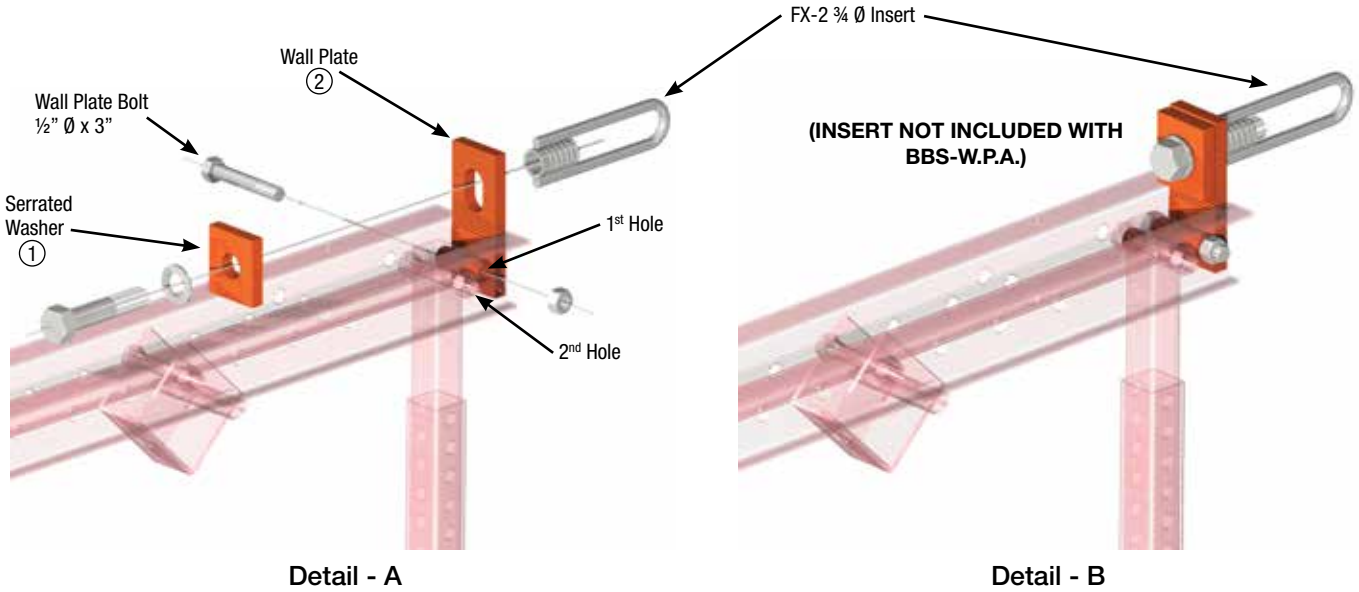

The Meadow Burke BBS-Wall Plate Assembly is for use when the BBS-54 or BBS-27 Overhang Bracket must be attached to a vertical concrete section. The BBS-Wall Plate Assembly has two pieces, item ①+② and will bolt into a cast insert or drill-in anchor which will allow the overhang bracket to be secured to the vertical wall. Simply place the Wall Plate Bolt through the first hole in the Overhang Bracket and through the welded pipe in the wall plate assembly. The Vertical Leg Bolt is then in the second hole. Use a minimum 3/4 inch diameter X 6 inch cast insert as an anchor.

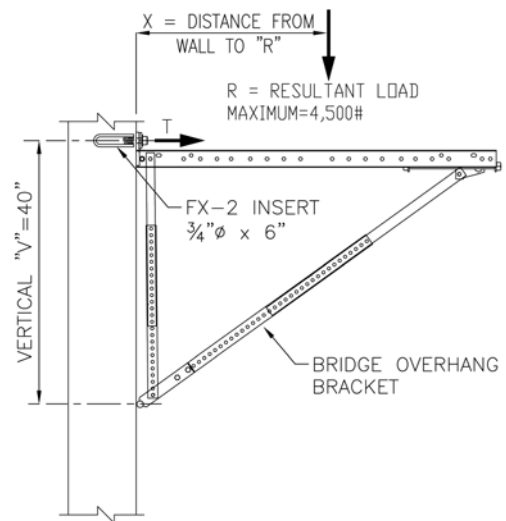
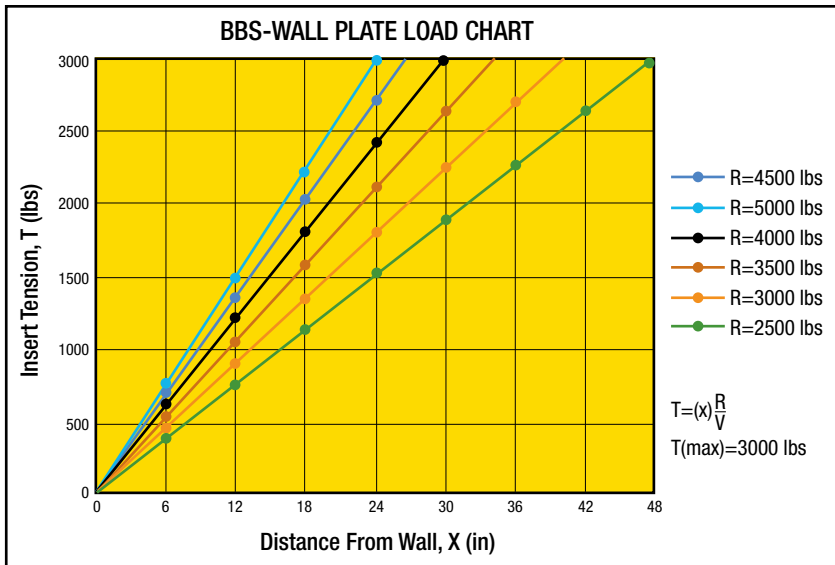

NOTE: Wall Plate Tension Load Chart for Meadow Burke BBS-Wall Mount Assembly is for a BBS-54 Bracket V-dimension of 40".

For V-dimension of 30" increase the Insert Tension-Value by 30%.

For V-dimension of 50" decrease the Insert Tension-Value by 20%.

To Order:
Specify quantity and name.

Example:
200pcs., BBS-Wall Plate assembly.

BBS-47 BURKE-STYLE BRACKET

The Meadow Burke BBS-47 is designed to be attached through the web of a steel beam with a 3/4" grade 5 bolt or a concrete beam with a 3/4" cast in place insert. Combined loading should always be calculated on the bolt and insert when used. The cradle assembly is designed to adjust vertically, while accepting up to 4' nominal sized lumber. The BBS-47 is light easy to assemble and light weight.

BBS-47 BURKE-STYLE BRACKET	
SPECIFICATIONS	BBS-47
Top Chord Length	47"
Maximum Vertical	25"
Top Chord Slopes with Bridge Deck Slope	No
Total Weight	59 lbs.
Maximum Vertical Load	4500 lbs.
Maximum Load Outer Jack	1500 lbs.
Maximum Load Inner Jack	3000 lbs.

Working loads are based on a 2:1 safety factor against failure.

WARNING:

- Do not exceed safe work load of this product.
- Brackets should be adjusted properly during the normal "dry run" operation.
- Do not attempt an upward adjustment during the concrete pouring operation.
- Do not lower bracket adjustment during the concrete pour.

To Order:

Specify quantity, type, name

Example:

350 pcs., BBS-47 Bridge Bracket.

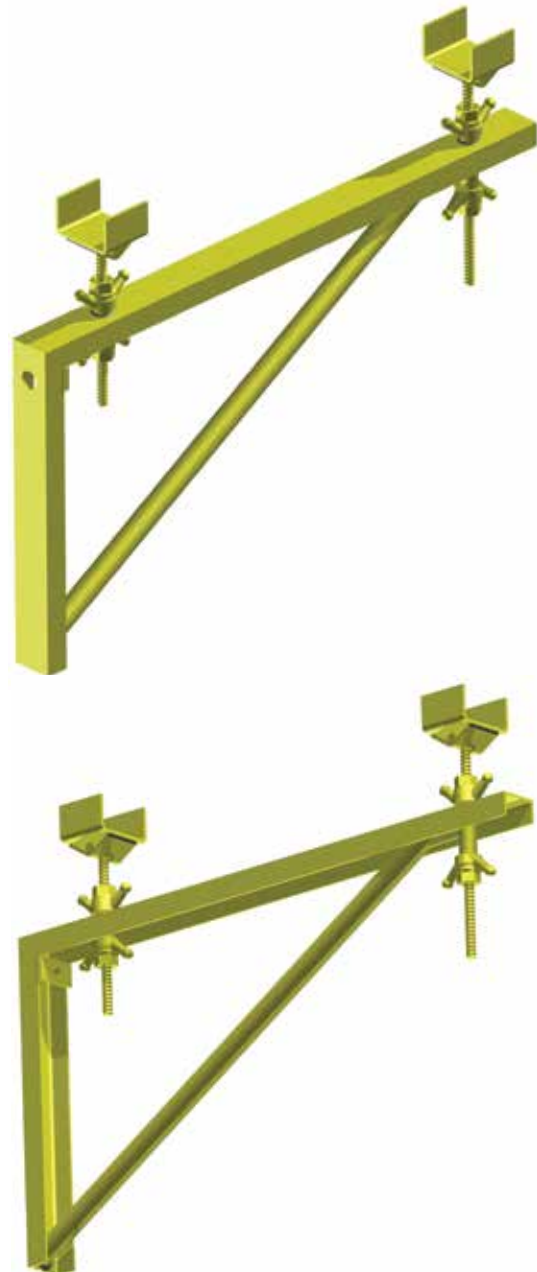

HF-15 STEEL HANGER FRAME

The HF-15 Hanger Frame is intended for use to support interior formwork. End sections allow for 1/2" coil bolts to be positioned at 15 degree angles away from the beam sides allowing the ledger support member to be away from the beam side. Hanger is adjustable from the topside of the formwork.

HF-15 STEEL HANGER FRAME (15°/15°)			
Type	Wire Ø	SWL/Side	Includes
HF-15 (STD)	0.375"	4500 lbs	(2) CN-5 1/2"
HF-15 (HD)	0.440"	6000 lbs	(2) CN-5 1/2"

Working loads are based on a 2:1 safety factor against failure.



To Order:
Specify quantity, type, measured beam width.

Example:
400 pcs., HF-15 (STD.), 12" beam width.

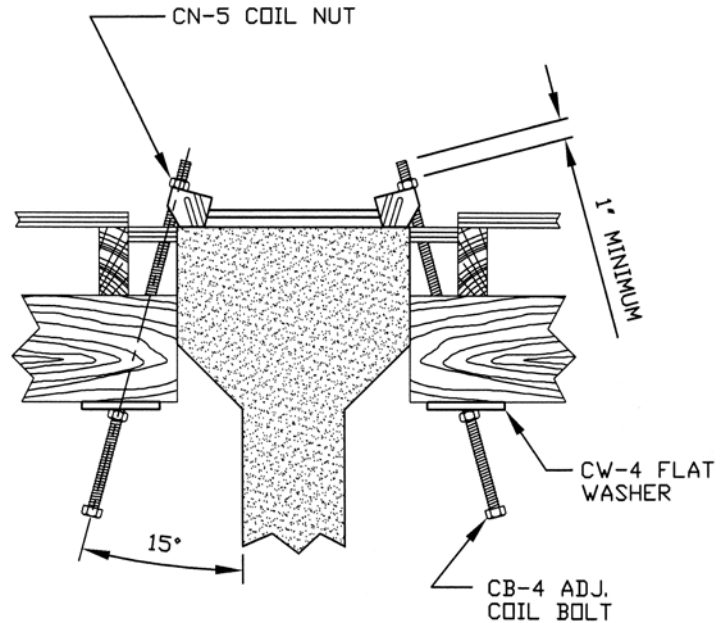

WARNING:

- Do not exceed safe work load of this product.
- Hangers must have bearing under each hanger end section.
- Contractor must carefully determine actual beam width before ordering hangers.
- Interior hangers must be equally loaded on both sides.

HF-17 STEEL HANGER FRAME

The HF-17 Hanger Frame allows for 1/2" coil bolts to be positioned at 15 degree and 45 degree angles away from the beam sides allowing the ledger support member to be away from the beam side. Hanger is adjustable from the topside of the formwork.

HF-17 STEEL HANGER FRAME (45°/15°)			
Type	Wire Ø	SWL/Side	Includes
HF-17 (STD)	0.375"	4500 lbs	(2) CN-5 1/2"
HF-17 (HD)	0.440"	6000 lbs	(2) CN-5 1/2"

Safety Factor approximately 2:1



To Order:
Specify quantity, type, measured beam width.

Example:
400 pcs., HF-17 (STD.), 12" beam width.

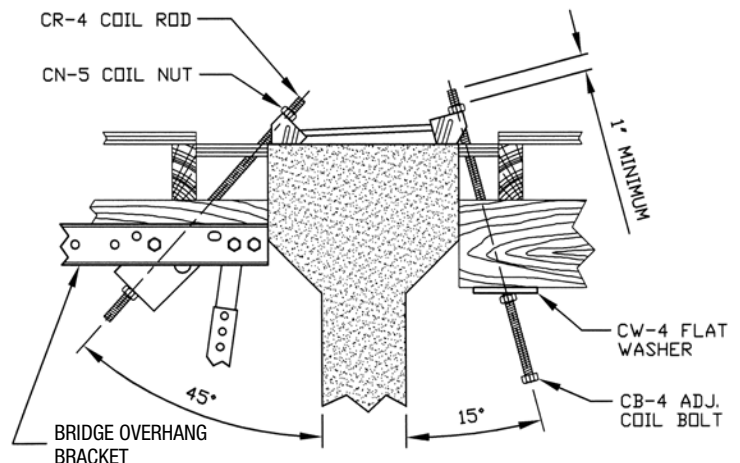

WARNING:

- Do not exceed safe work load of this product.
- Hangers must have bearing under each hanger end section.
- **Only use when screed machine runs on bridge girder and concrete is only load on overhang bracket and hanger.**
- If screed is on the overhang, contact Meadow Burke Engineering for special hanger with lockplate.

HF-22 STEEL HANGER FRAME

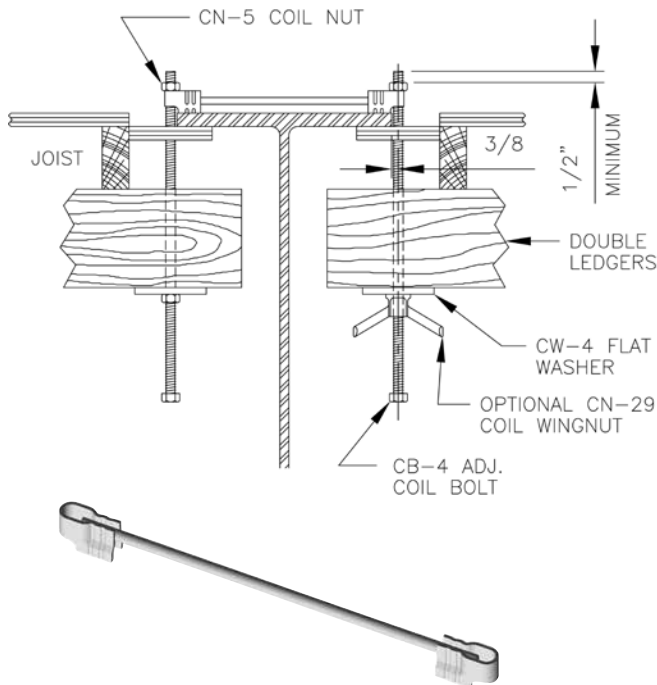

The HF-22 Interior Free Fit Hanger Frame is intended for steel or concrete beams and is typical of interior span forming. The 90/90 Free Fit Hanger is adjustable from the top side of the formwork, the HF-22 Hanger is desirable when no haunch condition exists.

HF-22 STEEL HANGER FRAME (90°/90°)			
Type	Angle	SWL/Side	Wire Ø
HF-22 (STD)	90°-90°	3500 lbs	0.375"
HF-22 (HD)	90°-90°	5000 lbs	0.440"

Safety Factor approximately 2:1

WARNING:

- Do not exceed safe work load of this product.
- Hangers must have bearing under each hanger end section.
- Contractor must carefully determine actual beam width before ordering hangers.
- Interior hangers must be equally loaded on both sides.

To Order:

Specify quantity, type and name, measured beam width.

Example:

350 pcs., HF-22 (STD) Steel Hanger Frame,
14-1/4" beam width.

HF-23 STEEL HANGER FRAME

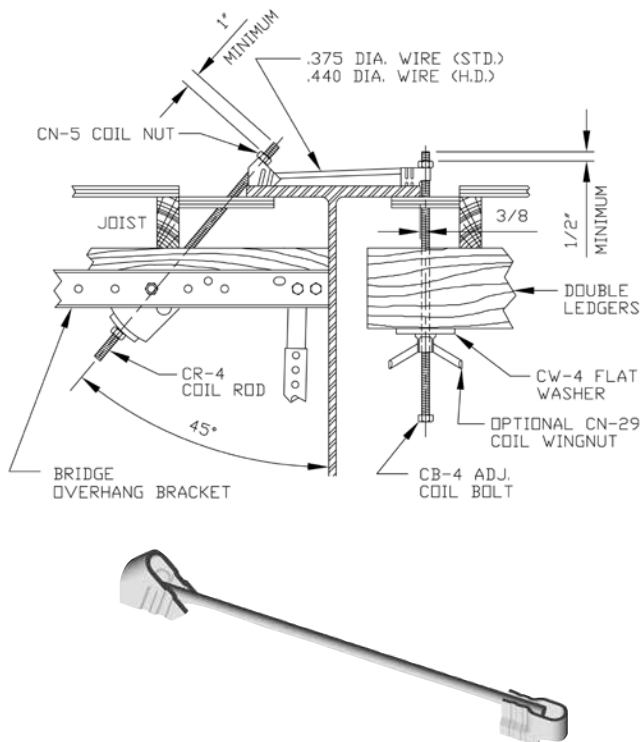

The HF-23 Exterior 45°/90° Frame is intended for steel or concrete beams and is typical of exterior overhang forming. The 45°/90° Free Fit Hanger is adjustable from the top side of the formwork and uses 1/2" coil rod or coil bolts as the 45° end section supports the overhang bracket. Bolt centerline must be within 3/8" of beam edge. The HF-23 Hanger is desirable when no haunch condition exists on the interior side.

HF-23 STEEL HANGER FRAME (45°/90°)			
Type	Angle	SWL/Side	Wire Ø
HF-23 (STD)	45°-90°	3500 lbs	0.375"
HF-23 (HD)	45°-90°	5000 lbs	0.440"

Safety Factor approximately 2:1

WARNING:

- Do not exceed safe work load of this product.
- Hangers must have bearing under each hanger end section.
- Contractor must carefully determine actual beam width before ordering hangers.
- **Only use when screed machine runs on bridge girder and concrete is only load on overhang bracket and hanger.**

To Order:

Specify quantity, type and name, measured beam width.

Example:

350 pcs., HF-23 (STD) Steel Hanger Frame,
14-1/4" beam width.

HF-24 HALF HANGER (STRAIGHT)

The HF-24 Half Hanger for concrete beams is furnished with a straight strut tail for welding to the beam stirrups. Either 45°, 90° or 15° hanger ends may be ordered with the straight tail. Other tail lengths are available.



To Order:

Specify quantity, type, name, angle and dimension "C."

Example: 350 pcs., HF-24 STD Half Hanger, 45°, C=9".

HF-24 HALF HANGER (STRAIGHT)					
Type	Angle	SWL	Wire Ø	"C"	Includes
HF-24 (STD)	15°	3500 lbs	0.375"	9"	(1) CN-5 ½"
HF-24 (STD)	45°	3500 lbs	0.375"	9"	(1) CN-5 ½"
HF-24 (STD)	90°	3500 lbs	0.375"	9"	(1) CN-5 ½"
HF-24 (HD)	15°	6000 lbs	0.440"	9"	(1) CN-5 ½"
HF-24 (HD)	45°	6000 lbs	0.440"	9"	(1) CN-5 ½"
HF-24 (HD)	90°	6000 lbs	0.440"	9"	(1) CN-5 ½"
HF-24 (HD)	90° SL	6000 lbs	0.440"	9"	(1) CN-5 ½"

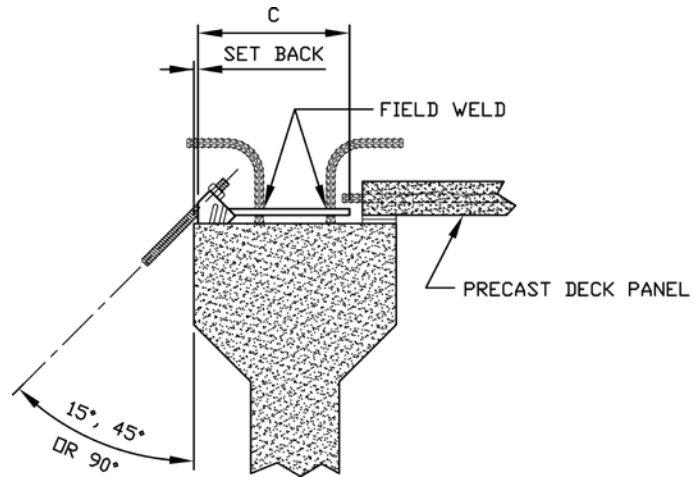

NOTE: Hanger must be installed with proper setback (distance from edge of beam to hanger end). Setbacks are as follows: ¼" for 45°, ⅛" for 15° and ⅙" for 90° hanger ends.

Caution: SWL is based on minimum concrete flange thickness of 5" and 5000 psi concrete strength.

WARNING:

- Do not exceed safe work load of this product.
- Hangers must have bearing under hanger end section.
- Only use certified welder.
- Improperly welded hangers in field may result in premature failure.
- Field tests are recommended to verify weld performance and actual safe workloads.
- See welding information on Page 59.

HF-25 HALF HANGER (FORMED)

The HF-25 Half hanger for concrete or steel beams is furnished with a formed strut tail. Either 45°, 90° or 15° hanger ends may be ordered with the formed tail.

HF-25 HALF HANGER (FORMED)				
Type	Angle	SWL	Wire Ø	Includes
HF-25 (STD)	15°	3500 lbs	0.375"	(1) CN-5 ½"
HF-25 (STD)	45°	3500 lbs	0.375"	(1) CN-5 ½"
HF-25 (STD)	90°	3500 lbs	0.375"	(1) CN-5 ½"
HF-25 (HD)	15°	6000 lbs	0.440"	(1) CN-5 ½"
HF-25 (HD)	45°	6000 lbs	0.440"	(1) CN-5 ½"
HF-25 (HD)	90°	6000 lbs	0.440"	(1) CN-5 ½"
HF-25	1" HH-90°	2375 lbs	0.375"	(1) CN-5 ½"
HF-25	1-½" HH-90°	2000 lbs	0.375"	(1) CN-5 ½"



To Order:

Specify quantity, type, name, angle, haunch height (if required) and dimension "C".

Example: 350 pcs., HF-25 (STD.) Half Hanger, 45°, C=12".

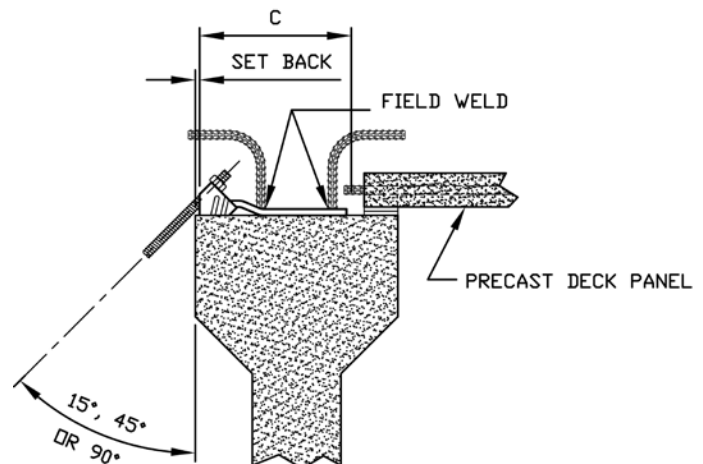

NOTE: Hanger must be installed with proper setback (distance from edge of beam to hanger end). Setbacks are as follows: ¼" for 45°, ⅛" for 15° and ⅙" for 90° hanger ends.

Caution: SWL is based on minimum concrete flange thickness of 5" and 5000 psi concrete strength.

WARNING:

- Do not exceed safe work load of this product.
- Hangers must have bearing under hanger end section.
- Only use certified welder.
- Improperly welded hangers in field may result in premature failure.
- Field tests are recommended to verify weld performance and actual safe workloads.
- See welding information on Page 59.

HF-26 HIGH HAUNCH STEEL HANGER FRAME

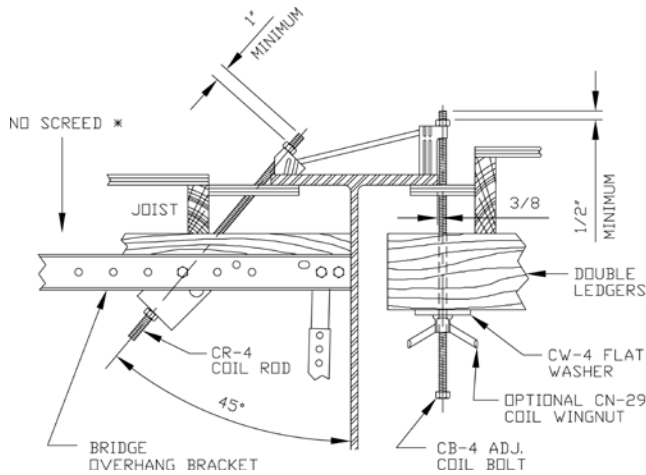

WARNING:

- Do not exceed safe work load of this product.
- Hangers must have bearing under each hanger end section.
- Contractor must carefully determine actual beam width before ordering hangers.
- **Only use when screed machine runs on bridge girder and concrete is only load on overhang bracket and hanger.**
- If screed is present, use HF-36

The HF-26 Hanger Frame is intended for use on steel or concrete beams. The 45°/90° High Haunch Free Fit Hanger is adjustable from the top side of the form, using ½" coil rod or coil bolts. Centerline of 90° bolt must be within ⅜" of beam edge. Height of haunch is available for 1", 1-½" and 2-½" haunch conditions. Specify when ordering. Hangers are to be used only with full bearing under end sections.

HF-26 HIGH HAUNCH STEEL HANGER FRAME (45°/90°)				
Type	Haunch Ht	SWL/90° SIDE	SWL/45° SIDE	Includes
HF-26	1"	2375 lbs	2375 lbs	(2) CN-5 ½"
HF-26	1-½"	2000 lbs	2000 lbs	(2) CN-5 ½"
HF-26	2-½"	1800 lbs	1800 lbs	(2) CN-5 ½"

Safety Factor approximately 2:1



To Order: Specify quantity, type and name, measured beam width, haunch.

Example: 350 pcs., HF-26 High Haunch Steel Hanger, 14-¼" beam width, 1-½" haunch.

HF-27 HIGH HAUNCH STEEL HANGER FRAME

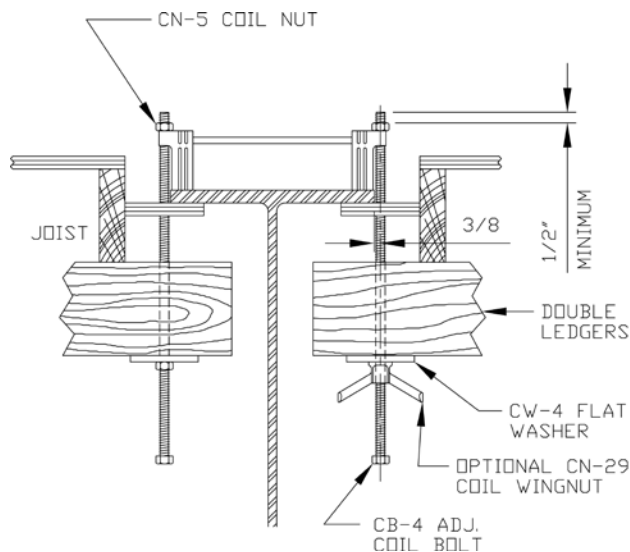

WARNING:

- Do not exceed safe work load of this product.
- Hangers must have bearing under each hanger end section.
- Contractor must carefully determine actual beam width before ordering hangers.
- Interior hangers must be equally loaded on both sides.

The HF-27 Hanger Frame is intended for use on steel or concrete beams. The 90°/90° High Haunch Free Fit Hanger is adjustable from the top side of the form, using ½" coil rod or coil bolts. Centerline of bolts must be within ⅜" of beam edge. Height of haunch is available for 1", 1-½" and 2-½" haunch conditions. Specify when ordering. Hangers are to be used only with full bearing under end sections. The contractor must carefully determine the actual beam width before ordering hangers

HF-27 HIGH HAUNCH STEEL HANGER FRAME (90°/90°)			
Type	Haunch Ht	SWL/SIDE	Includes
HF-27	1"	2375 lbs	(2) CN-5 ½"
HF-27	1-½"	2000 lbs	(2) CN-5 ½"
HF-27	2-½"	1800 lbs	(2) CN-5 ½"

Safety Factor approximately 2:1



To Order: Specify quantity, type and name, measured beam width, haunch.

Example: 350 pcs., HF-27 High Haunch Steel Hanger, 14-¼" beam width, 1-½" haunch.

HF-29 HALF HANGER

The HF-29 Hook Half Hanger is designed for use on concrete or steel beams, and can be fabricated with the crosswire welded in place or loose for welding in the field. Furnished with a pre-formed loop to fit around second stirrup. Careful consideration to length must be made to insure 45° end is at proper position. Available in 15°, 45° or 90° hangers.

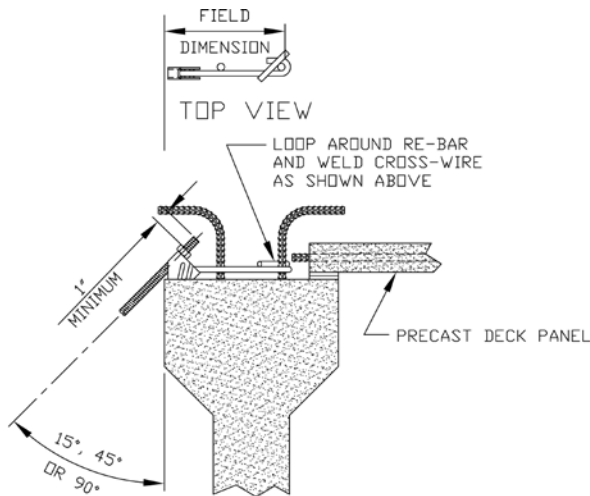

HF-29 HALF HANGER - SLIP ON			
Type	Angle	SWL	Includes
HF-29	15°	3000 lbs	(1) CN-5 ½"
HF-29	45°	3000 lbs	(1) CN-5 ½"
HF-29	90°	3000 lbs	(1) CN-5 ½"

Safety Factor approximately 2:1

WARNING:

- Do not exceed safe work load of this product.
- Hangers must have full bearing under each hanger end section.
- Crosswire must be welded to both wire struts, see Field Welding notes on page 47.
- Field tests are recommended to verify performance and actual safe work load.

To Order: Specify quantity, type and name, angle, distance from edge of beam to back of stirrup, stirrup diameter.

Example: 350 pcs., HF-29 Hook Half Hanger, 45°, 8" from edge of beam to back of stirrup, ¾" stirrup diameter.

HF-33 SIDE LOCK HANGER - 45°

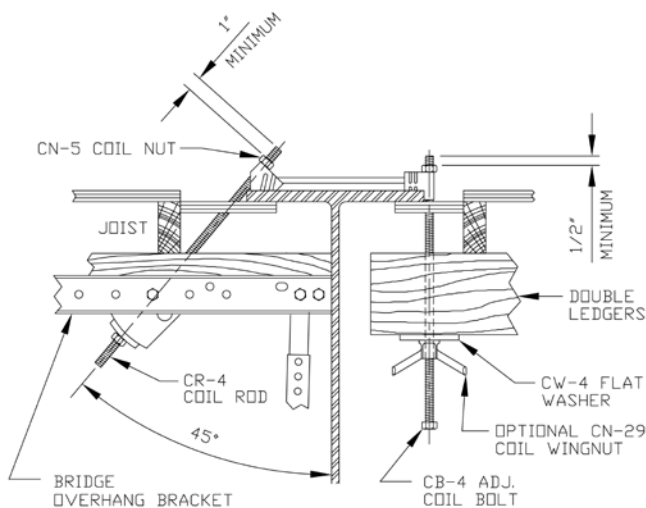

The HF-33 Side Lock Hanger is specifically intended for use on outside beams when a mechanical screed machine is to be supported by the bridge overhang. The 45°/90° heavy duty free fit end clip is adjustable from the top side of the form, using ½" coil rod or coil bolts. This hanger is suitable for either steel or concrete beams. The 90° side lock feature prevents the hanger (when under a load), from sliding towards the 45° edge.

HF-33 SIDE LOCK HANGER (45°/90°)			
Type	SWL	Includes	Wire Ø
HF-33 (STD)	4500 lbs	(2) CN-5 ½"	0.375
HF-33 (HD)	6000 lbs	(2) CN-5 ½"	0.440



WARNING:

- Do not exceed safe work load of this product.
- Hangers must have bearing under each hanger end section.
- Contractor must carefully determine actual beam width before ordering hangers.

To Order: Specify quantity, type and name, measured beam width.

Example: 50 pcs., HF-33 (STD) Side Lock Hanger, 14-¼" beam width.

HF-30/31 PRECAST EMBED HANGER (STD)

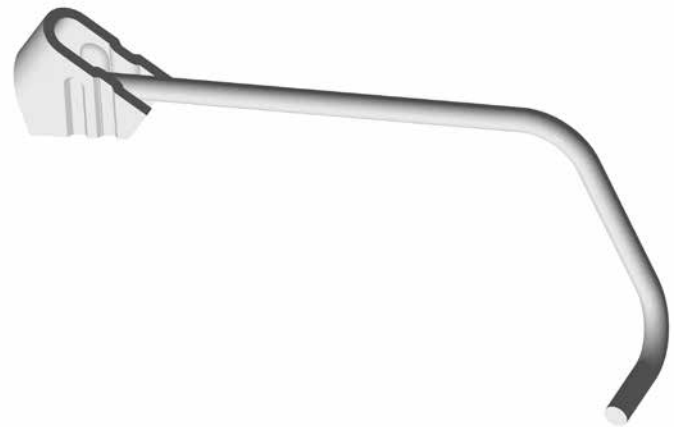
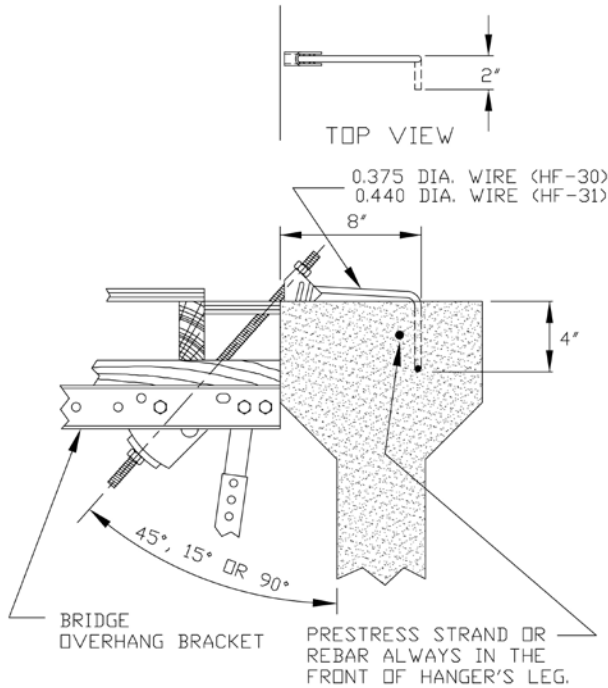

The Meadow Burke HF-30 and 31 Precast Embed Hangers are designed for use in concrete beams only. Hangers are installed in the wet concrete during casting of the precast beams. Care must be exercised to prevent hanger “sinking into the concrete” and to provide a 1/4 inch setback from the sideform. Load calculations must be made to ascertain that any predetermined hanger spacing is compatible with actual job loading conditions. There is no front leg on the HF-30 and 31. See page 61 for Meadow-Burke Engineering Submittal Forms to determine hanger and B.O.B. spacing and loads.

To Order:
Specify quantity, type, name, angle, and size.

Example:
350 pcs., HF-30 Steel Hanger Frame,
45°, 8-4-2. (Other sizes available)

PRECAST EMBED HANGERS				
Type	Angle	Number of Legs	I-BEAM SWL OR SIMILAR SWL (lbs)	Bulb Tee* 3.5"-5" SWL (lbs)
HF-30	45°	1	5000	5000
HF-30	90°	1	3000	3000
HF-31	45°	1	6000	6000
HF-31	90°	1	4000	4000

Safety Factor approximately 2:1 *Flange width = 52" max ** HF-67 see page 46.

CAUTION:

* Bulb Tee Special Notes:

- Do not use above hangers when Bulb Tee flange is less than 3.5 inches.

WARNING:

- Do not exceed safe work load of this product.
- Hangers must have full bearing under each hanger end section.
- Do not allow hangers to sink into beam during casting operation.
- Actual safe work load depends on field conditions.
- Field tests are recommended to verify performance and actual safe work load.
- Available with plate under hanger end for wet setting applications.

HF-34 SIDE LOCK HANGER - 90°

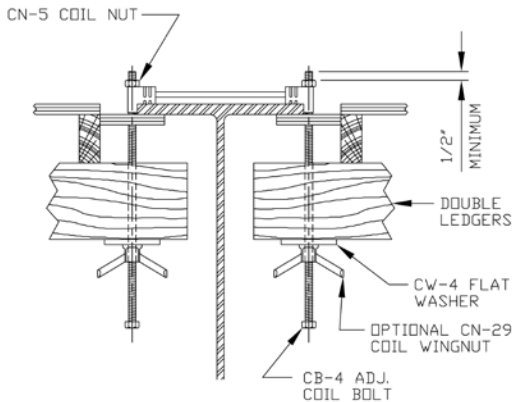

WARNING:

- Do not exceed safe work load of this product.
- Hangers must have bearing under each hanger end section.
- Contractor must carefully determine actual beam width before ordering hangers.

The HF-34 Side Lock Hanger is made with two 90° end sections, one at each end, and is designed to accept a 1/2" diameter coil rod. This hanger is designed primarily for interior beams and can be installed on steel or concrete beams. The coil rod extending upward through the 90° ends is adjustable from the top side allowing for variable elevations of the form work. **When ordering, must submit actual measured beam dimensions.**

HF-34 SIDE LOCK HANGER (90°/90°)			
Type	SWL	Includes	Wire Ø
HF-34 (STD)	4500 lbs	(2) CN-5 1/2"	0.375
HF-34 (HD)	6000 lbs	(2) CN-5 1/2"	0.440

Safety Factor approximately 2:1



To Order: Specify quantity, type and name, measured beam width.

Example: 50 pcs., HF-33 (STD) Side Lock Hanger, 14-1/4" beam width.

HF-35 SIDE LOCK HOOK HANGER

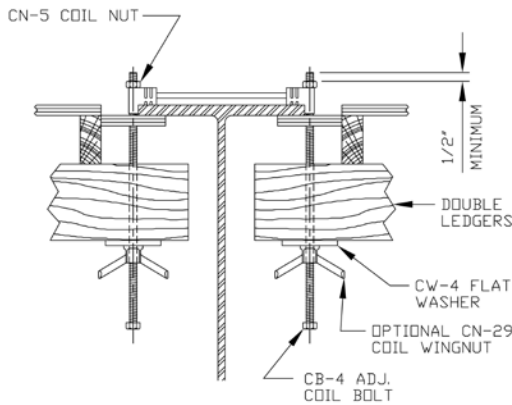

The HF-35 Hook Hanger is available with a 15°, 45° or 90° end section designed to accept a 1/2 inch diameter coil rod. The opposite end wraps around the flange of a steel beam with a "hook" which secures the hanger to the beam. This hook is manufactured with a tolerance of approx. 1/8" greater than the measured flange thickness to assure a proper fit. The hook has a heavy 90° end section welded to the hook, providing additional strength. When ordering, customer must submit actual dimensions of the flange. If the flange is bigger than 14"x 3" use the HF-37 hanger. **When ordering, must submit actual measured beam dimensions.**

To Order: Specify quantity, type and name, angle, measured beam width, flange thickness.

Example: 500 pcs., HF-35 Hook Hanger, 45°, 12" beam with, 1-1/4" flange thickness.

Type	SWL
1.0"	5500 lbs
1.5"	4900 lbs
2.0"	4250 lbs
2.5"	3600 lbs
3.0"	2950 lbs

HF-36 LOCK PLATE HAUNCH HANGER

The HF-36 Lock Plate Hanger is specifically recommended when interior haunch conditions are combined with the need to support mechanical screed loads on the bridge overhang bracket. The 90°/45° free fit end clips are welded to a ¼" thick steel plate which is clipped over the flange for strength. The plate size must be such that the end clips are positioned over the top of the flange. This Hanger is suitable for either steel or concrete beams.

HF-36 LOCK PLATE HAUNCH HANGER (45°/90°)				
Type	Haunch Ht	SWL/90° Side	SWL/45° Side	Includes
HF-36	1"	2800 lbs	4000 lbs	(2) CN-5 ½"
HF-36	1-½"	2800 lbs	4000 lbs	(2) CN-5 ½"
HF-36	2-½"	2800 lbs	4000 lbs	(2) CN-5 ½"

Safety Factor approximately 2:1

WARNING:

- Do not exceed safe work load of this product.
- Hangers must have bearing under each hanger end section.
- Contractor must carefully determine actual beam width before ordering hangers.

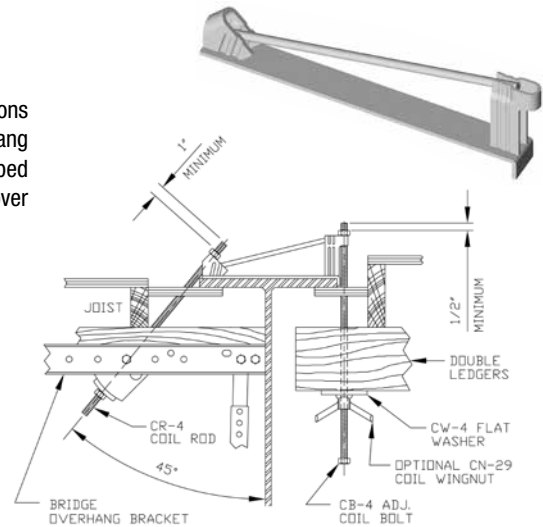

HF-37 CLIP HANGER

The HF-37 Clip Hanger is made with 0.44" Ø wire, and is available with 45° or 90° end section and is designed to accept a ½ inch dia. coil rod. The hook clip on the opposite end is sized and made to fit a steel beam. The end clip is sized to fit over the flange and provides lateral restraint due to only one side being loaded. When ordering, must submit actual measured dimensions of the flange. Order Special HF-37 when flange thickness is greater than 1.9"

HF-37 CLIP HANGER				
Type	Angle	SWL	Includes	Additional Notes
HF-37*	45°	6000 lbs	(1) CN-5 ½"	Use CN-25 or (2) CN-5 to reach 7000 lbs SWL
HF-37	90°	5000 lbs	(1) CN-5 ½"	

Safety Factor approximately 2:1

WARNING:

- Do not exceed safe work load of this product.
- Hangers must have full bearing under each hanger end section.
- Hook-clip must fit over flange edge.
- If loose, hook-clip may be shimmed to make snug.
- If hook-clip will not fit over flange, do not use.
- Max flange size is 7" x 22" long.

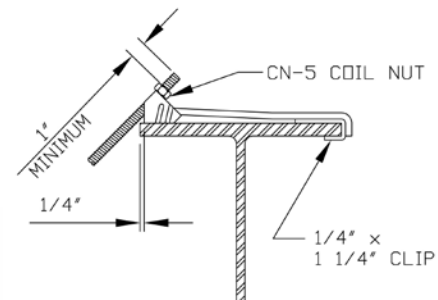

To Order Products On This Page: Specify quantity, type and name, angle, measured beam width, flange thickness.

Example: 500 pcs., HF-37 Hook Hanger, 45°, 16" beam width, 1-¼" flange thickness.

HF-38, 45°/90° BROACH HANGER

The HF-38, 45/90 Broach Hanger is made with .440 diameter wire and has a standard 45° end piece welded on one end. This hanger provides a 1 in. breakback on the 90° side and will accept a ½ in. coil rod on the 45° side. The 90° rod is threaded a minimum 9 inches.

Caution: The 90° side may require blocking to prevent lateral movement due to the 45° load. Both sides of hanger should be loaded at same time to prevent unbalanced loading.

HF-38 BROACH HANGER		
Type	SWL	Nut Ø
HF-38	4500 lbs	½"

Nut Sold Separately.
Available in 45°/15°

Safety Factor approximately 2:1

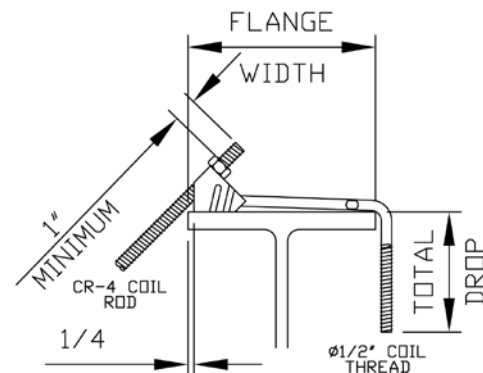
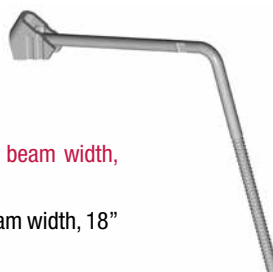

To Order: Specify quantity, item number and name, measured beam width, total drop, and thread length.

Example: 350 pcs. HF-38, 45° Broach Hanger, 15" measured beam width, 18" total drop, 7" thread length.

HF-39, 90°/90° BROACH HANGER

The HF-39, 90/90, Broach Hanger is made with .440 diameter wire and fabricated to job specifications. The actual width is made ½ in. longer than the measured beam width to accommodate the bends in the wire hanger. The rod ends are threaded with ½ coil thread. The HF-39 has an anti-turn wire welded in the center of the hanger. It also provides a standard 1 in. breakback. Also available as a 15° / 15° hanger.

Caution: Hangers must be equally loaded on both sides. Nuts Sold Separately

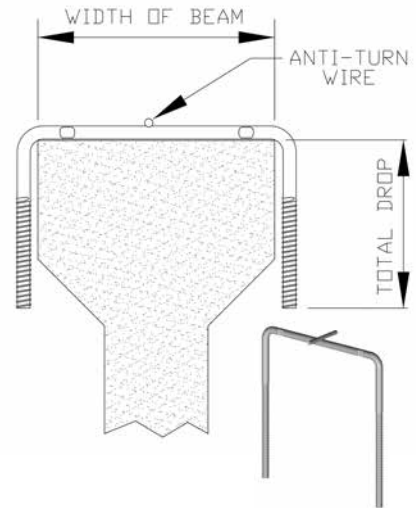

HF-39 BROACH HANGER		
Type	SWL	Nut Ø
HF-39	4500 lbs	½"

Safety Factor approximately 2:1

To Order: Specify quantity, item number and name, measured beam width, total drop, and thread length.

Example: 350 pcs. HF-39, 90° Broach Hanger, 12" measured beam width, 20" total drop, 9" thread length

HF-40 ADJUSTABLE HALF HANGER

The HF-40 Adjustable Half Hanger is intended for either steel or concrete beams when welding to the stirrups or to top of steel beam flange is not permitted. If hanger with one clip is ordered, then 3 coil nuts ½" diameter are supplied and if two clips are ordered then 5 coil nuts, ½" diameter are supplied. Available with 15°, 45° or 90° hanger ends. Standard length is 8 inches, other lengths available. Rebar or welded stud diameter options: ½", 5/8", ¾", 7/8", and 1". Must secure or tighten each clip prior to application of load.

HF-40 ADJUSTABLE HALF HANGER				
Type	Angle	SWL 1 Clip	SWL 2 Clip	Includes
HF-40	15°	1100 lbs	3000 lbs	3) CN-5 ½" and (1) U-Clip
HF-40	45°	1100 lbs	3000 lbs	
HF-40	90°	2800 lbs	3000 lbs	

Safety Factor approximately 2:1

WARNING:

- Do not exceed safe work load of this product.
- Hangers must have full bearing under each hanger end section.
- Contractor must determine actual stirrup diameter and stirrup locations before ordering.
- Coil nuts must collapse the clip tightly around the stirrups on concrete beams or welded shear studs on the steel beams.
- Less than a tight connection will result in premature failure.
- Field tests are recommended to verify performance and actual safe work load.
- Notes:

One Clip option comes with three nuts, two of which are used in product assembly.
Two Clip option comes with five nuts, four of which are used in product assembly.

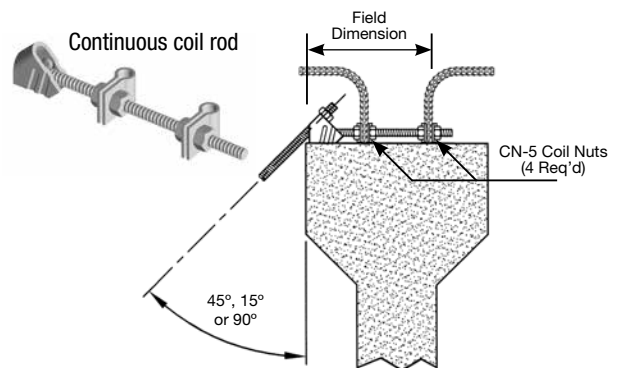

To Order: Specify quantity, type and angle, number of clips, stud Ø, field dimension

Example: 350 pcs., HF-40 Adjustable Half Hanger, 45°, 2-clips, stud Ø=½" length, 9"

HF-41 HOOK BOLT

The HF-41 Hook Bolt can be used in conjunction with the HF-33 Side Lock Hanger as a substitute for the HF-35 Hook Hanger.

Note: The SWL is dependent upon application. The thicker the flange the lower the SWL.

To Order: Specify quantity, type and thread length, number of clips, stud Ø.

Example: 350 pcs., HF-41 Adjustable Half Hanger, 45°, 2-clips, stud Ø=½" length

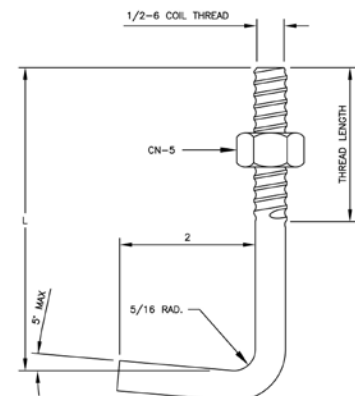

HF-44 ADJUSTABLE HALF HANGER-PLATE

Meadow Burke's new HF-44 Adjustable Half Hanger-Plate is a hanger designed for use with concrete beams where precast hangers have not been installed during the precast operation, where precast hangers were installed at incorrect spacing or where retro procedures are not desirable. The plate hole is approximately 1/4" larger than the rebar. Horizontal adjustment of up to 1/2" may be made in either direction. Just position the plate hole over the shear bar and with shear bar through the plate hole, slide hanger to base of shear bar and then adjust hanger length to 1/4" setback from edge of beam.

Note: In all applications the shear bars or stirrups must be perpendicular with top of beam surface, not bent or sloped in the direction of the hanger. If necessary, bend bars to perpendicular or slight reverse direction from hanger.

HF-44 ADJUSTABLE HALF HANGER (45°)					
Type	Shear Bar Size	"A" Ø (IN)	"B" Length (in)	"D" Width (in)	SWL
HF-44	#4	.5625	3.5625	2.0	4000
HF-44	#5	.6875	3.6875	2.0	4500
HF-44	#6	.8125	3.8125	2.0	5000
HF-44	#7	.9375	3.9375	2.0	5500
HF-44	#8	1.0625	4.0625	2.25	6000
HF-44	#9	1.1875	4.1875	2.25	6000
HF-44	#10	1.3125	4.3125	2.25	6000

Caution: SWL is based on minimum concrete flange thickness of 3.5".

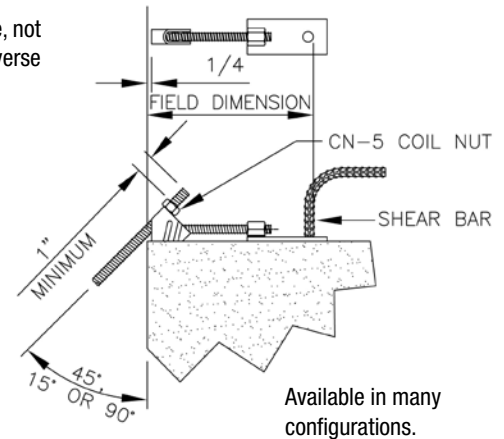
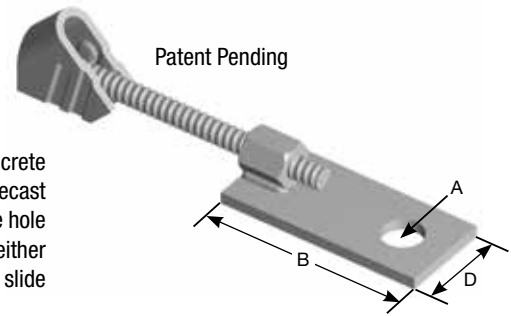

To Order: Specify quantity, type and name, distance from edge of beam to back of stirrup, and diameter of stirrup.

Example: 350 pcs., HF-44 Adjustable Half Hanger-Plate, 7-1/4" to back of stirrup, 5/8" Ø stirrup.

HF-64 HANGER FOR WELDED STUD

The HF-64 Hanger is useful when one side of the beam is not accessible, such as bridge widening projects. A 3/4 inch diameter threaded stud may be welded to the top flange (similar to other shear studs), and the HF-64 hanger with a special 90° end fits over the threaded stud and is secured with a 3/4 inch UNC nut. Actual safe working load is mainly dependent on the weld of the stud to the flange. Care must be taken to assure a proper weld in the field.

The HF-64 Hanger may also be used on a concrete beam by drilling a hole in the top flange of the beam and epoxy grouting. See page 60.

HF-64 HANGER FOR WELDED STUD (45°)				
Type	SWL/Side	Bolt Diameter		Includes
		90° Side	45° Side	
HF-64	6000 lbs	3/4"	1/2"	(1) CN-5 1/2" (1) 3/4" UNC Nut

Safety Factor approximately 2:1

WARNING:

- Do not exceed safe work load of this product.
- Hangers must have full bearing under each hanger end section.
- Welding hangers in the field improperly may result in premature failure.
- Field tests are recommended to verify performance and actual safe work load.

To Order: Specify quantity, type and name, Field Dimension.

Example: 350 pcs., HF-64 Hanger for welded stud, Field Dimension=9".

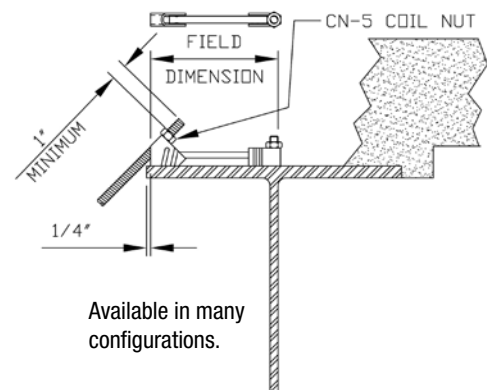

BBA-96 & BA-96L

ALUMINUM BRIDGE OVERHANG BRACKETS

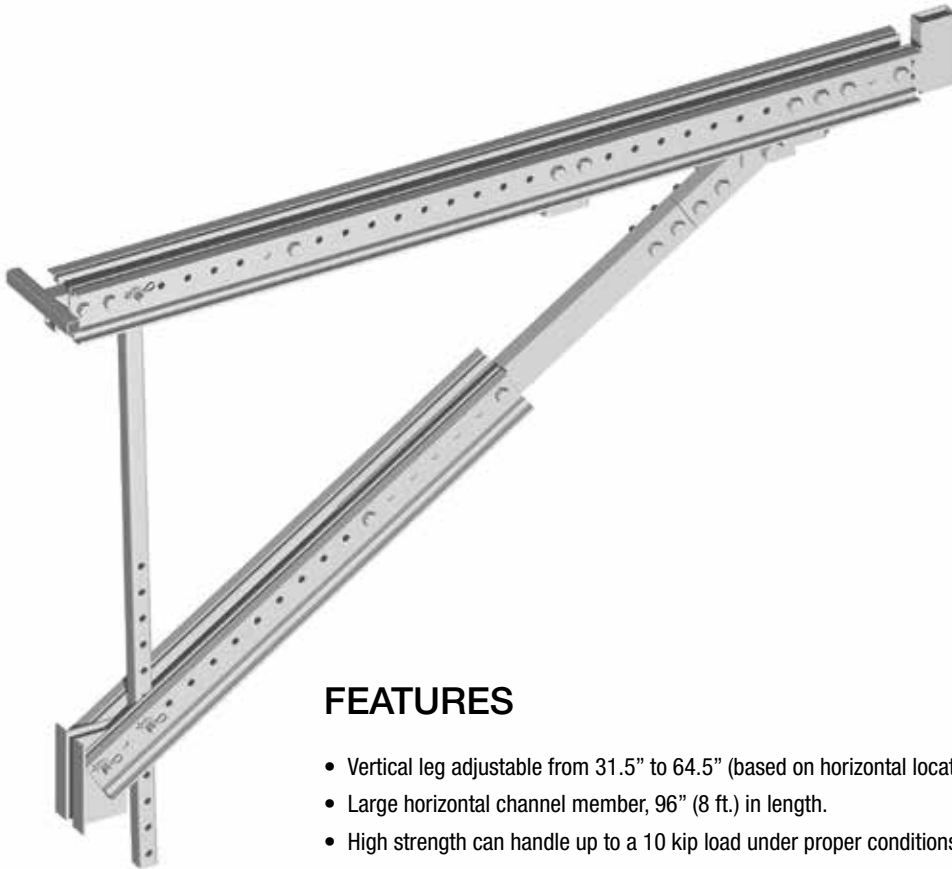

FEATURES

- Vertical leg adjustable from 31.5" to 64.5" (based on horizontal location on diagonal member).
- Large horizontal channel member, 96" (8 ft.) in length.
- High strength can handle up to a 10 kip load under proper conditions.
- Lightweight construction for easier handling, less equipment demand and less labor to reduce costs on the jobsite.
- Due to the rotational adjustability of the bracket, raised falsework is no longer necessary for inclined slab overhang. (Reduction of falsework of almost 100%)
- Quick and easy minor adjustment from the bridge deck to save as much time as possible.
- Diagonal member of bracket is adjustable in length (66.5" to 99.5" or 55" to 67"), height and distance for an effective transfer of the resulting forces, mainly due to the screed load.
- Higher degree of safety due to adjustable guardrail for sloped or super elevated decks.
- Bracket is shipped partially assembled. Easy to assemble to specific conditions.
- No need for additional 2x6 on top chord of Bracket.
- Gang forming of multiple Brackets with aluminum joist beams of up to 24 feet option available.
- Diagonal Load = Maximum 9 kip

BBA-96 & BBA-96L ALUMINUM BRACKET ASSEMBLY

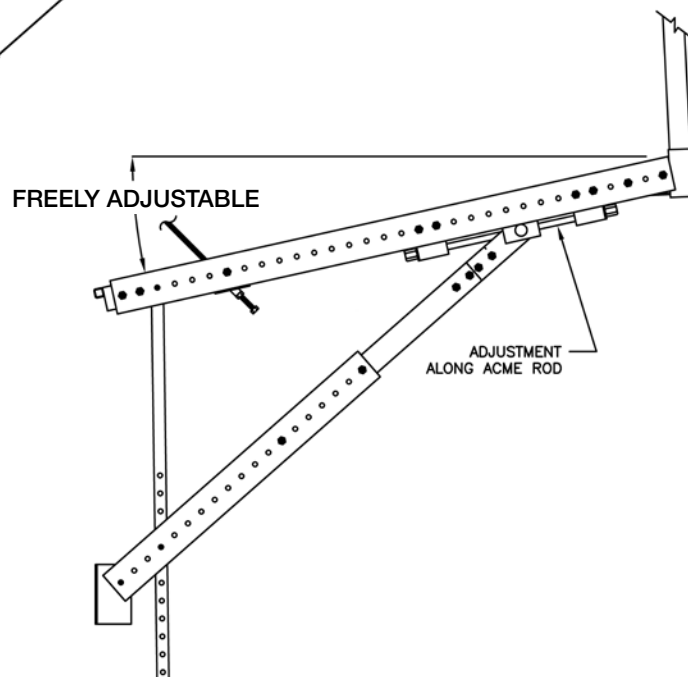
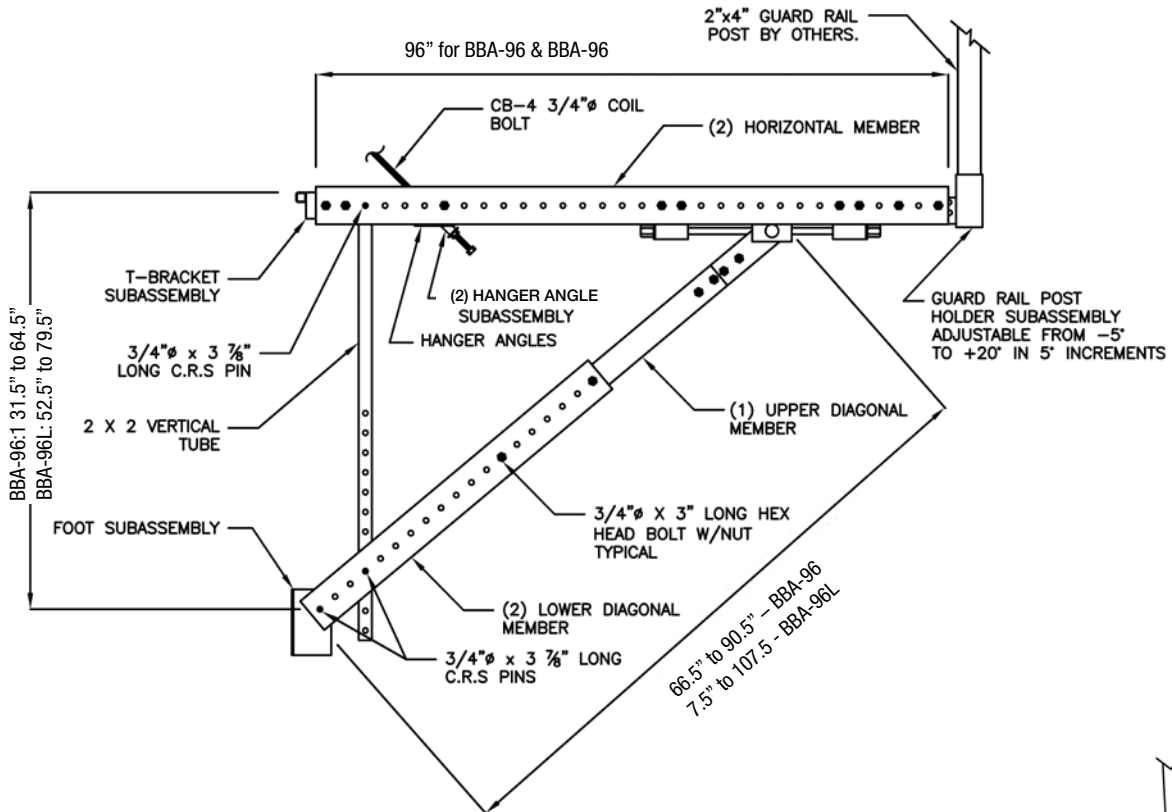

To Order:
Specify quantity, type and name.

Example:
350 pcs., BBA-96 Aluminum Bridge Overhang Bracket.

- WARNING:**
- Brackets should be adjusted properly during the normal "dry run" operation.
 - Do not attempt an upward adjustment during the concrete pouring operation.
 - Do not lower bracket adjustment during the concrete pour.

ADAPTABILITY

- The BBA-96 & BBA-96L aluminum brackets are designed for use on steel and concrete beams.



ADJUSTABILITY

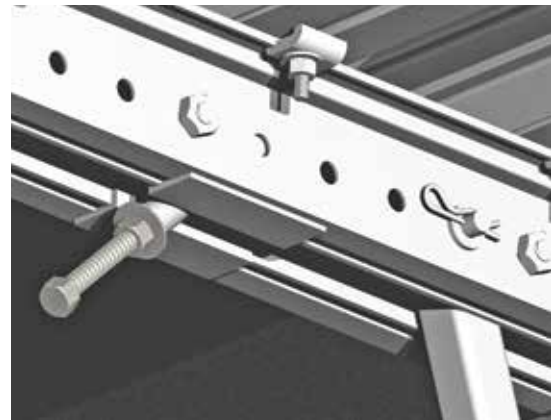
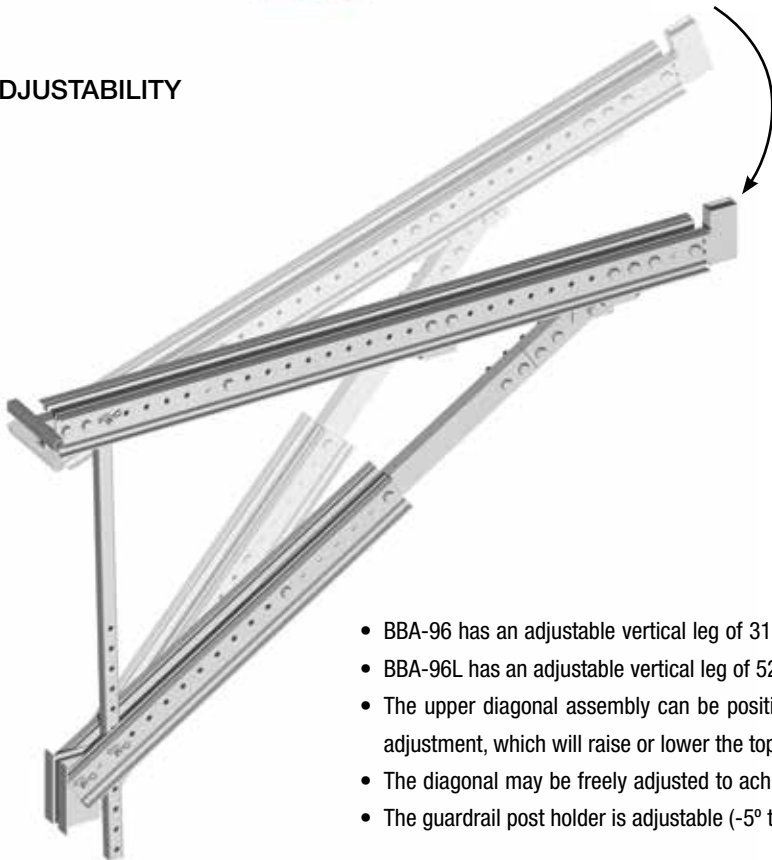

- BBA-96 has an adjustable vertical leg of 31 ½" to 64 ½" (based on the horizontal location of the diagonal member).
- BBA-96L has an adjustable vertical leg of 52 ½" to 79 ½" (based on the horizontal location of the diagonal member).
- The upper diagonal assembly can be positioned at 3" increments and when bolted in place, has a 15" horizontal adjustment, which will raise or lower the top chord (horizontal member) accordingly.
- The diagonal may be freely adjusted to achieve a vertical rotation of the top chord with as much as 2000 lbs. load.
- The guardrail post holder is adjustable (-5° to 20° in 5° increments)

ENGINEERING:

Meadow Burke has tested the BBA-96 for deflection at specific loads and configurations. The resultant force of all the combined loads (screed, concrete, form, walkway and live load) is generally located approximately 4 to 8 inches inside the location of the screed load. Meadow Burke Engineering located the single test load at 6 inches as an approximate average. The location of the applied load to the Bracket is also the point of measured deflection. Testing with this loading condition, results in a more accurate approximation, of actual loading than any previous testing by any other manufacturer.

Following are three typical configurations with accompanying test curve data.

Description:

MB BBA-96 Aluminum 96 in. B.O.B. (load placed at 73.5" from inboard end of Bracket; deflection measured at end of bracket, V-dimension=56") Diagonal member @ 79.5" from inboard end of Bracket.

Failure: No Failure.
Pre-loaded to approx. 6K and then released. 1" deflection (buckling) of the diagonal.

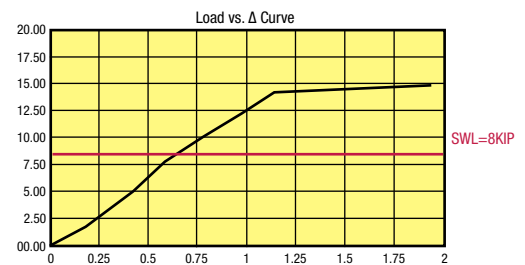
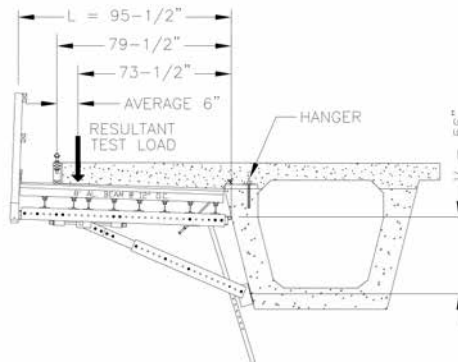

Description:

MB BBA-96 Aluminum 96 in. B.O.B. elevated at 22 Degree (load placed at 61.5" from inboard end; deflection measured at end of bracket and at Resultant Load).

Failure: No Failure.
Pre-loaded to approx. 6K and then released. 1/2" deflection (buckling) of the diagonal.

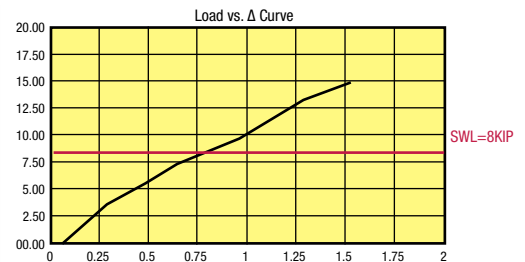
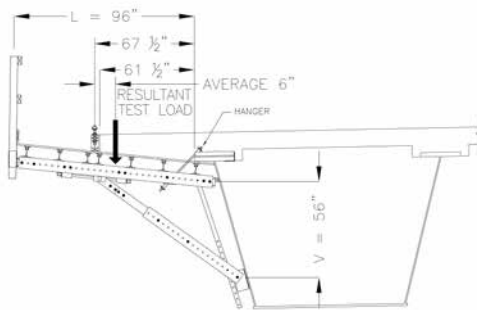

Description:

MB BBA-96 Aluminum 96 in. B.O.B. (load placed at 52.75" from inboard end; deflection measured at end of bracket, V-dimension= 67") Diagonal member @ 59" from inboard end of Bracket.

Failure: No Failure.
Pre-loaded to approx. 6K and then released. 1/8" deflection (buckling) of the diagonal.

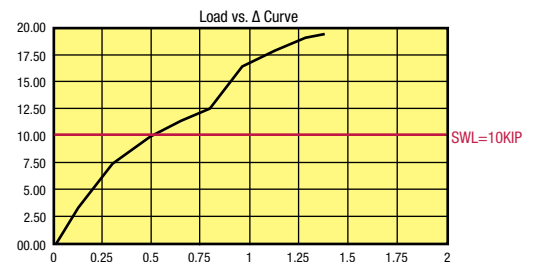
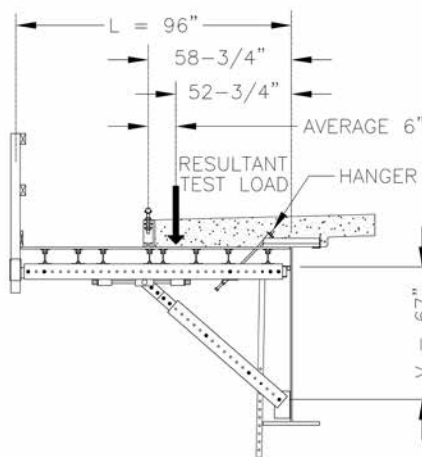

BBA-ALUMINUM CLIP ASSEMBLY

BBA-ALUMINUM JOIST BEAM

In addition to the Aluminum Brackets, Meadow Burke also provides a 5.50 inch high Aluminum Joist to reduce the overall weight of the assembled overhang system. As a result of the joist material being aluminum, instead of wood, the joist spacing will be greater and installation costs lower. It is available in 18, 21, and 24 foot lengths.

HF-91 clamps are available which secure the HF-92 joist beam to the Aluminum Brackets. The HF-92 joist beam has a nailer insert so the installation of the plywood is as fast as usual.



BBA - WALL MOUNT ASSEMBLY

Meadow Burke's BBA-Wall Mount Assembly used when the Aluminum Bridge Overhang Brackets must be attached to a vertical concrete or steel section. The WMA comes with two parts; the rigid mount and the washer. The WMA replaces the T-Bracket assembly at the end of the Aluminum Bracket's top chord. The T-Bracket's bolts are used to attach the WMA to the Aluminum Bracket. Then WMA attaches to the vertical concrete or steel section via a slotted hole that accepts a 1" diameter bolt or post installed anchor. The SWL for the WMA is 10,000Lbs in Tension and 10,000 in Shear with a 2:1 factor of safety.

ALUMINUM JOISTS ASSEMBLY

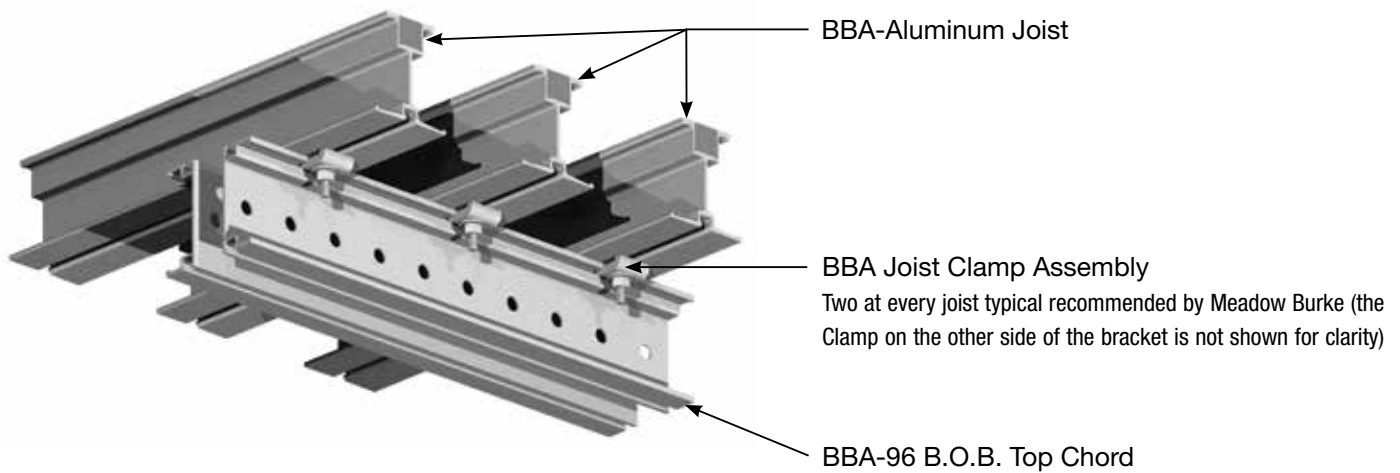

33 - 40

ALUMINUM BRACKET GANG FORMING

When a crane is available at the jobsite, and reducing labor is an objective, "gang" forming may be the answer. Gang forming occurs when a group of brackets are properly spaced and secured to joists and plywood in a rigid unit. This assembly is to be set in place and later removed from the bridge as a single "ganged" unit.

On a straight bridge the "gang" can be up to 24 ft. long. On bridges that have a curve or a radius, the "gang" will be shorter to accommodate this condition. To determine the length of a gang form, the following items must be considered; Overhang Bracket spacing, crane capabilities, C-caddie, aluminum joist length, job site suitability, and repeatability.

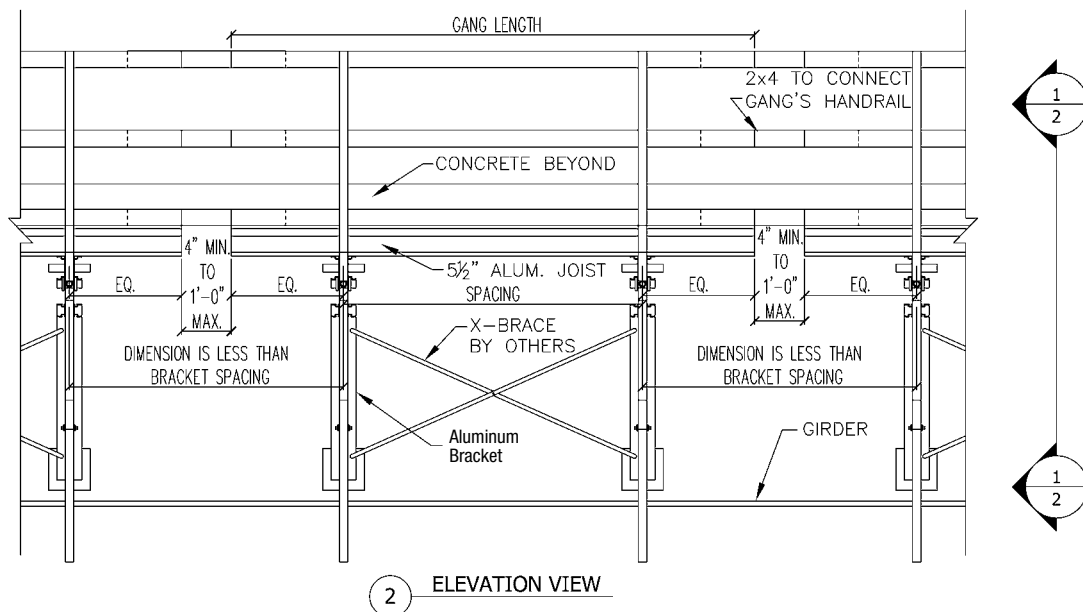
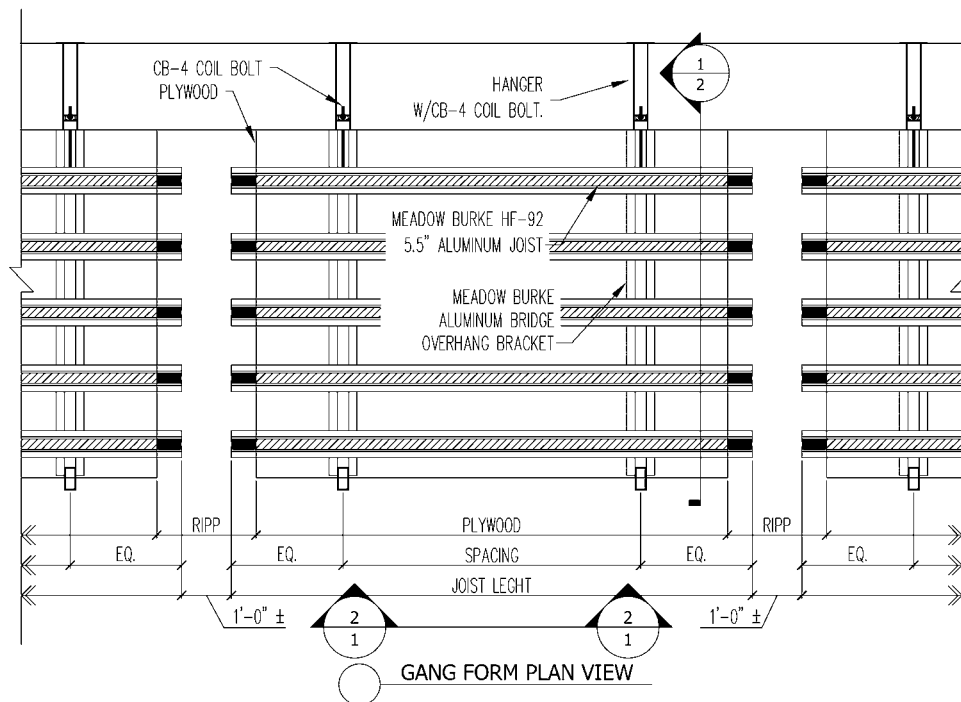

ALUMINUM BRACKET GANG FORMING (continued)

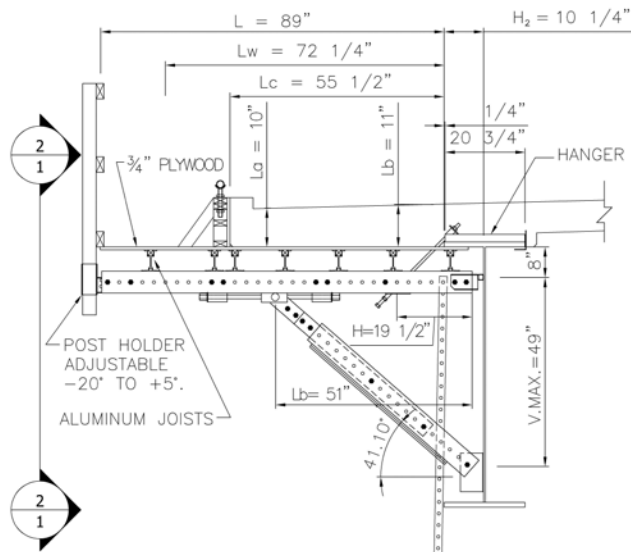

1 TYPICAL SECTION

pg 41. gang forming with HF-96

Typical section from the drawing on the previous page. The “gang” forming method can be used on a wide variety of different girder types and sizes. The “gang” method can also accommodate a steep angle under the slab for super elevated conditions. Refer to the end of the catalog for more sections showing different conditions with different types of girders.

FEATURES NOT AVAILABLE WITH OTHER BRACKETS.



1. Diagonal adjustment is acme thread for ease of adjustment under load.
2. Diagonal adjustment assembly may be moved to alternate locations.
3. Post holder may be bolted at angle to permit vertical post when bracket is sloped.
4. Aluminum joists may be clamped to the brackets at ground level.
5. Gangforming of brackets and joists is practical.
6. No other bracket has a greater load capacity than the BBA-96.
7. No other bracket has the extension length capability of the BBA-96.
8. Special lengths and capacities are available.
9. Easier access for final vertical adjustments.
10. Can be adjusted to follow the contour of the concrete overhang, eliminating costly false work.

NOTES

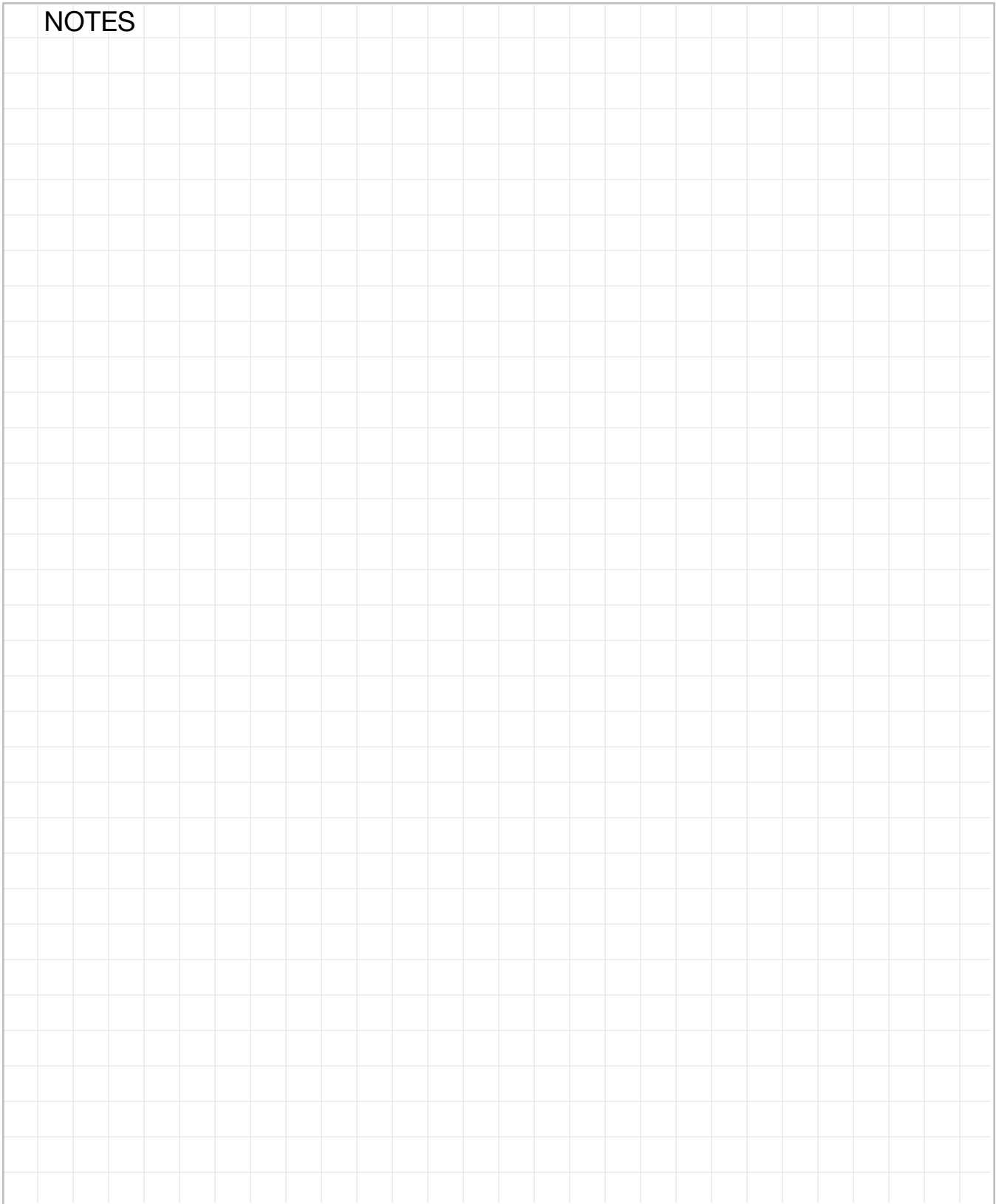
A large rectangular area filled with a light gray grid pattern, intended for handwritten notes. The word "NOTES" is printed in the top-left corner of this grid area.

HF-61 BAR HANGER 45°

Meadow Burke's Bar Hangers are designed to accommodate 3/4 inch dia. coil rod and to provide Safe Work Loads of up to 12M each. The HF-61 is a 45° hanger for steel beams with a rectangular tube on one end to receive the coil rod and a welded angle on the opposite end to fit securely around the flange of the steel beam. The HF-61 hangers *must* be used with the *Heavy Duty Bridge Overhang Bracket on steel beams*.

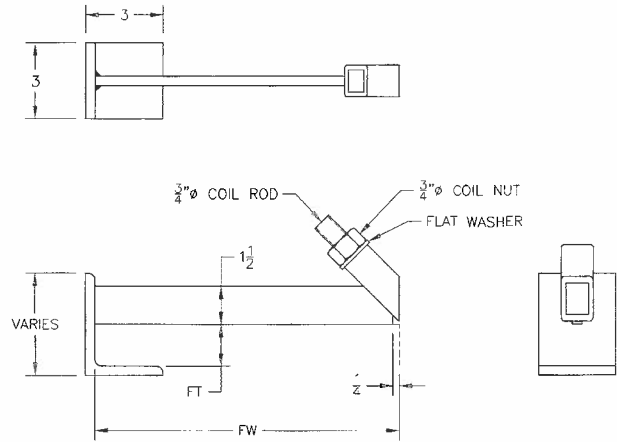

HF-61 (45°) 12M HANGER		
Flange Width (FW) Min.~Max.	SWL	Safety Factor
6"~48"	12000 lbs	2:1

NOTES:

1. Safe working load requires the hanger to have the correct set back from the face of the beam.
2. Advertised product length is available in 1/4" increments.
3. Minimum coil bolt penetration per Meadow Burke literature applies to coil nuts.
4. The following finishes are available: Plain, Electro-plated, and Hot-dipped Galvanized.

To Order:

Specify quantity, type, name, SWL, and measured beam width and flange thickness, and field dimension.

Example:

350 pcs., HF-61 Bar Hangers for Steel Beam, 9M, 16" flange, 1" flange thickness.

HF-62 BAR HANGER 90°

Meadow Burke's Bar Hangers are designed to accommodate 3/4 inch dia. coil rod and to provide Safe Work Loads of up to 12M each. The HF- 62 is a 90° hanger for steel beams with a vertical rectangular tube on one end to receive the coil rod and a welded angle on the opposite end to fit securely around the flange of the steel beam.

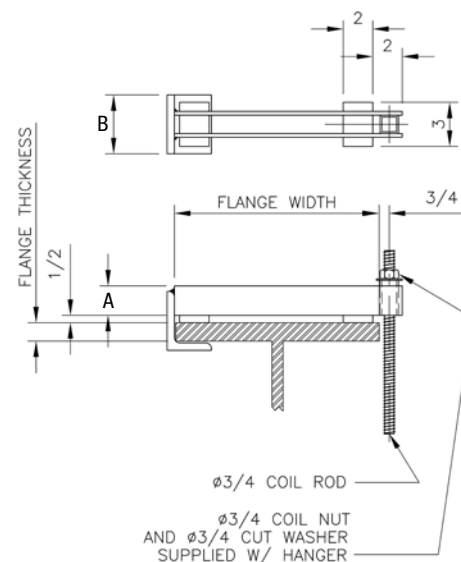

HF-62 SUPER BAR HANGER (45°)				
Type	A	B	SWL	Includes
HF-62	1.5"	3"	9000 lbs	(1) CN-5 3/4" & (1) WASHER 3/4"
HF-62	2"	4"	12000 lbs	

Safety Factor approximately 2:1

To Order:

Specify quantity, type, name, SWL, and measured beam width and flange thickness, and field dimension.

Example:

350 pcs., HF-62 Bar Hangers for Steel Beam, 9M, 16" flange, 1" flange thickness.

HF-65 EMBED BAR HANGER

Meadow Burke's Bar Hangers are designed to accommodate 3/4 inch diameter coil rod and to provide Safe Work Loads of up to 12,000 lbs. each. The HF-65 is a 45° hanger designed for concrete beams. This hanger has a rectangular tube on one end to receive the coil rod and has a second vertical tube on the opposite end to fit over a pre-installed anchor bolt. This hanger is available with Safe Work Loads of 9M or 12M.

CAUTION: If concrete beams have been produced without coil rod anchors installed, user must drill hole and epoxy grout a coil rod anchor in place. Any coil rod that is not perpendicular may be bent by slipping a pipe over the coil rod and bending in the desired direction. Do not bend if more than 20° alignment correction is necessary. If more than 20° correction is required, drill for new coil rod anchor (see *Bridge Hanger Repair Procedure*, Page 60).

WARNING: Do not use on bulb tee beams.

HF-65 SUPER BAR HANGER (45°)			
Type	B	SWL	Includes
HF-65	1.5"	9000 lbs	(1) CN-5 3/4" & (1) WASHER 3/4"
HF-65	2"	12000 lbs	

Safety Factor approximately 2:1

To Order:
Specify quantity, type and name, SWL and field dimension.

Example:
350 pcs., HF-65 Embed Bar Hanger, 9M, "FD"=16"

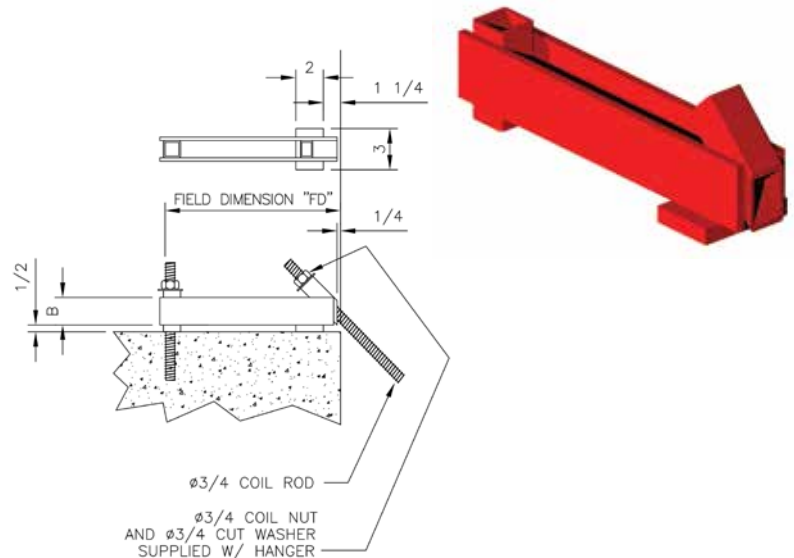

HF-67 BULB TEE HANGER

The HF-67 is designed for application on thin flange Bulb Tee beams and has a 6000lb Safe Work Load. A *special bearing plate* is welded to the 45° end which moves the bearing point back from the flange edge and allows a larger load to be carried by the concrete.

CAUTION: If concrete beams have been produced without coil rod anchors installed, user must drill hole and epoxy grout a coil rod anchor in place. Any coil rod that is not perpendicular may be bent by slipping a pipe over the coil rod and bending in the desired direction. Do not bend if more than 20° alignment correction is necessary. If more than 20° correction is required, drill for new coil rod anchor (see *Bridge Hanger Repair Procedure*).

HF-67 BULB TEE BAR HANGER (45°)					
Type	Supported Bracket	SWL	Bolt Ø		Includes
			90° Side	45° Side	
HF-67	BBS-54 or BBS-27	6000 lbs	3/4"	1/2"	(1) CN-5 3/4" (1) CN-5 1/2" (2) WASHERS
HF-67	BBA-72, 96 or BBS-72, 90	6000 lbs	3/4"	3/4"	(2) CN-5 3/4" (2) WASHERS

Safety Factor approximately 2:1

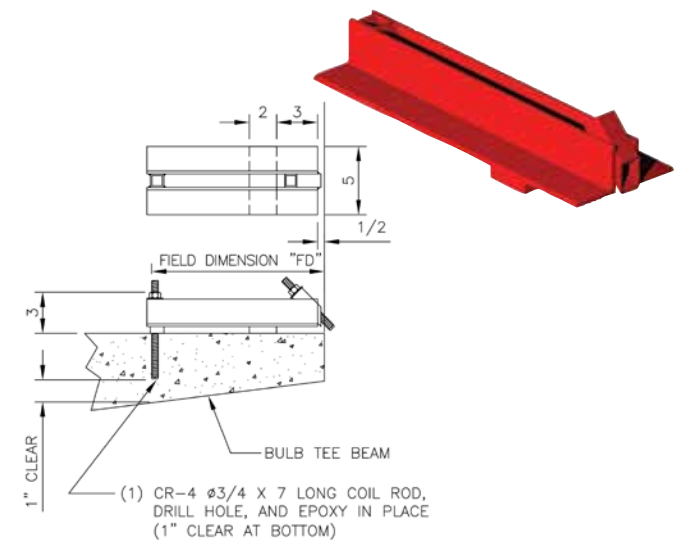

To Order:
Specify quantity, type and name, SWL and field dimension.

Example:
350 pcs., HF-67 Bulb Tee Bar Hanger for Bulb Tee, 6M, "FD"=16".

HF-73 ADJUSTABLE TANDEM BAR HANGER

This specialty designed 45° hanger by Meadow Burke is made with tandem coil rod members attached to a pair of angles to bolt around a beam shear bar of ½ inch or better diameter.



HF-73 ADJUSTABLE TANDEM HANGER (45°)						
Type	Shear Bar Ø	Flat Bar Size	Supported Bracket	SWL	Bolt Ø	Includes
HF-73	½"	1-½"	BBS-54*	4000 lbs	½"	(1) CN-5** & (1) WASHER
HF-73	½"	1-½"	BBA-96	4000 lbs	¾"	
HF-73	⅝"	1-½"	BBS-54*	5500 lbs	½"	
HF-73	⅝"	2"	BBA-96	5500 lbs	¾"	
HF-73	¾"	2"	BBA-96	7000 lbs	¾"	

*Includes BBS-54 & BBS-54L & BBS-27 **This number does not include 4 nuts used in product assembly.

Safety Factor approximately 2:1

CAUTION: Angles must be parallel to each other and perpendicular to the hanger axis. Nuts must be tight.

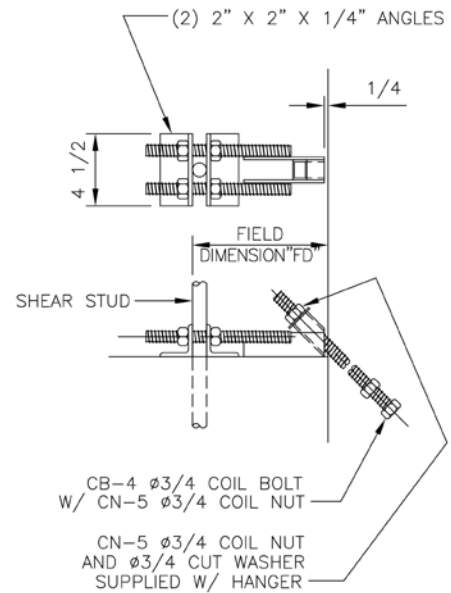

To Order:
Specify quantity, type, SWL, and field dimension.

Example:
350 pcs., HF-73 Adjustable tandem Bar Hanger
SWL 5500 lbs., FD=10".

HF-75 HALF HAUNCH BAR HANGER 90°

The HF-75 is a 90° hanger that will accommodate various size haunches from 1 inch height up to 4 inch heights. Another version of Meadow Burke's Bar Hangers, this model has a bearing plate under the vertical height tube member to provide for better stability. This hanger requires that a hole drilled to a depth of 4-½ inches, cleaned out, and a coil rod anchor be epoxy installed to provide anchorage to the opposite end. (See Bridge Hanger Repair Procedure). The offset from beam to bolt centerline is 1-½ inch, however, the vertical tube for the coil bolt may allow rotation of the bolt approx. 7° which may permit another ½ inch offset (depending on haunch height). This hanger uses ¾ coil rod bolts.

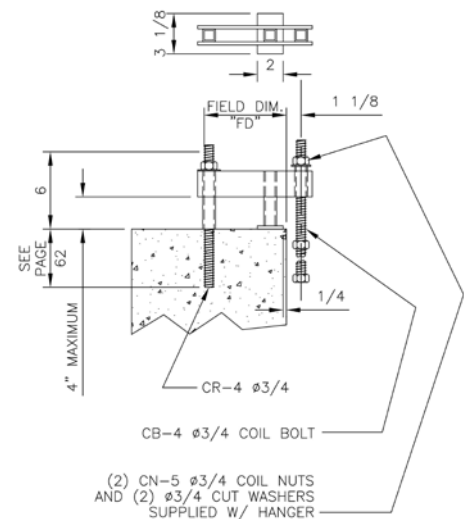
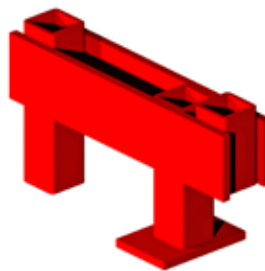

To Order:
Specify quantity, type and name, Haunch Height, and field dimension.

Example:
350 pcs., HF-75 Half Haunch Bar Hanger,
Haunch Height=2", FD=10".

HF-75 HALF HAUNCH BAR HANGER (90°)			
Type	Haunch Height	SWL	Includes
HF-75	1"	9000 lbs	(2) CN-5 ¾" (2) WASHERS ¾"
HF-75	2"	9000 lbs	
HF-75	3"	9000 lbs	
HF-75	4"	7500 lbs	

Safety Factor approximately 2:1

HF-76 HAUNCH BAR HANGER 90°/90°

The HF-76 is a 90°/90° hanger that will accommodate various size haunches from 1 inch height up to 4 inch heights. Another version of Meadow Burke's Bar Hangers, this model has a bearing plate under each vertical height tube member to provide for better stability. The offset from beam to bolt centerline is 1 1/8 inch, however, the vertical tube for the coil bolt may allow rotation of the bolt approx. 7° which may permit another 1/2 inch of offset (depending on the haunch height). This hanger uses 3/4 coil rod bolts.

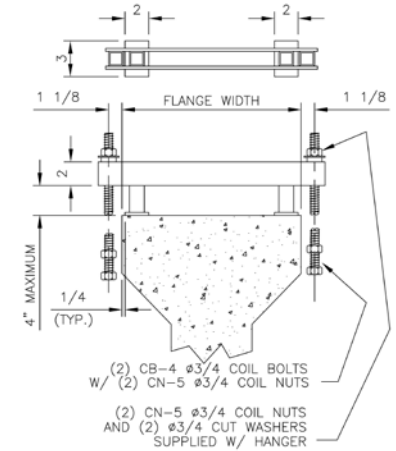
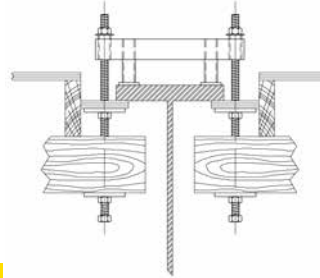

HF-76 HAUNCH BAR HANGER (90°/90°)			
Type	Haunch Height	SWL	Includes
HF-76	1"	9000 lbs	(2) CN-5 3/4" (2) WASHERS 3/4"
HF-76	2"	9000 lbs	
HF-76	3"	9000 lbs	
HF-76	4"	7500 lbs	

Safety Factor approximately 2:1

To Order:

Specify quantity, type and name,
Haunch Height, Measured flange width.

Example:

350 pcs., HF-76 Haunch Bar Hanger,
Haunch Height=2", Flange Width=10".

HF-77 HAUNCH BAR HANGER/LOCK PLATE 45°/90°

The HF-77 is a 45°/90° hanger that will accommodate various size haunches from 1 inch height up to 4 inch heights. This version of Meadow Burke's Bar Hangers has 45 end and a 90 end all welded to a 1/4 inch steel plate which "hooks" over the top of the flange for lateral restraint. This hanger may be used on either steel or concrete beams. The offset from beam to bolt centerline is 1-1/8 inch. This hanger uses 3/4 coil rod bolts.

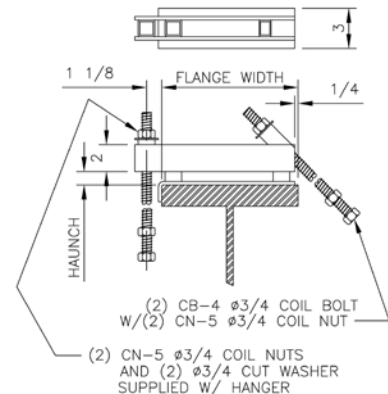
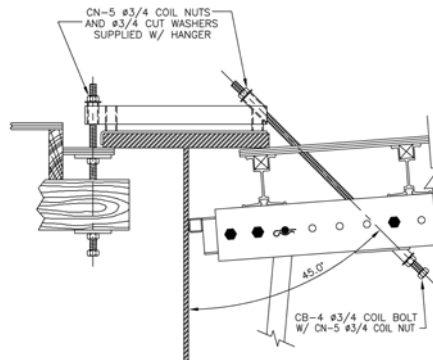

HF-77 HAUNCH BAR HANGER/LOCK PLATE (45°/90°)			
Type	Haunch Height	SWL	Includes
HF-77	1"	9000 lbs	(2) CN-5 3/4" (2) WASHERS 3/4"
HF-77	2"	9000 lbs	
HF-77	3"	9000 lbs	
HF-77	4"	7500 lbs	

Safety Factor approximately 2:1

To Order:

Specify quantity, type and name,
Haunch Height, measured flange width.

Example:

350 pcs., HF-77 Haunch Bar Hanger/Lock Plate,
Haunch Height=2", Flange Width=10".

CN-29 COIL WING NUT

The CN-29 Coil Wing Nuts are furnished with coil thread and are available in ½” through 1-½” diameters. The ductile iron Coil Wing Nut offers high strength, speedy tightening and release.

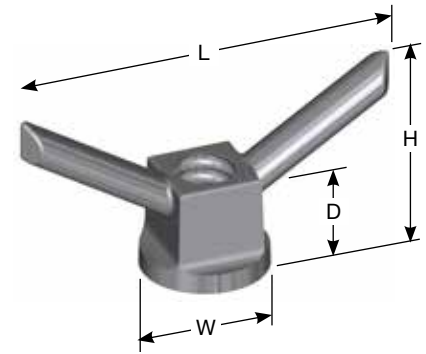

CN-29 COIL WING NUT DATA					
Diameter	L	D	H	W	SWL (lbs)
½”	5”	1-¼”	2-¾”	1-¾”	9,000
¾”	5-7/8”	1-¼”	2-½”	1-¾”	18,000
7/8”	6”	1-5/8”	2-¾”	1-¾”	18,000
1”	6”	1-5/8”	3”	2”	38,000
1-¼”	6-5/8”	1-5/8”	2-¾”	2-¼”	52,000
1-½”	6-¾”	1-7/8”	2-¾”	2-7/8”	80,000

Safe working load is based on an approximate 2:1 safety factor.

To Order, Specify: quantity, type and diameter.

CW-4 FLAT WASHER

The CW-4 Flat Washers are manufactured from high carbon flat steel plate and are designed to provide the required bearing against the form members. Flat Washers are available in many sizes in both standard and heavy versions. Refer to the Table for dimensions.

CW-4 FLAT WASHER DATA			
STANDARD WASHER		HEAVY WASHER	
Bolt Diameter	Size	Bolt Diameter	Size
½”	¼ x 3 x 4	½”	¼ x 4 x 5
¾”	¼ x 4 x 5	¾”	½ x 5 x 5
1”	½ x 5 x 5	1”	¾ x 7 x 7
1-¼”	½ x 5 x 5	1-¼”	¾ x 7 x 7
1-½”	¾ x 5 x 5	1-½”	¾ x 7 x 7



To Order, Specify: quantity, type, standard or heavy and bolt diameter.

CN-5 COIL NUT – STANDARD

The CN-5 Standard Coil Nut is manufactured from hex stock and is available in ½” through 1-½” diameters. Dimensions are displayed in the Table.

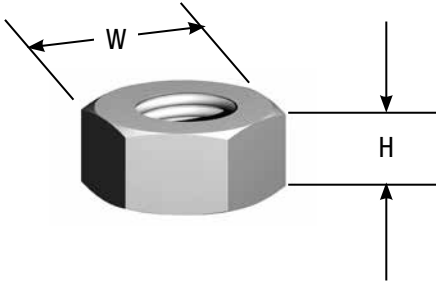

CN-5 COIL NUT - STANDARD DATA			
Diameter	Flat Width (W)	Height (H)	SWL (lbs)
½”	⅞”	½”	6,000
¾”	1-⅛”	⅝”	12,000
¾”	1-¼”	¾”	12,000
1”	1-⅝”	1”	18,000
1-¼”	2”	1-¼”	27,000
1-½”	2-⅜”	1-½”	40,000

Safe working load is based on an approximate 2:1 safety factor.

NOTE: In order to achieve the published safe working loads of Coil Bolts, Coil Rods, etc. when using the Standard Coil Nut; two (2) Standard Coil Nuts tightly locked together are required.

To Order, Specify: quantity, type and diameter.

CN-25 COIL NUT – HEAVY

The CN-25 Heavy Coil Nuts are manufactured from hex stock like the Standard Coil Nut but is of sufficient length to develop the safe working loads required for medium and heavy form tying systems.

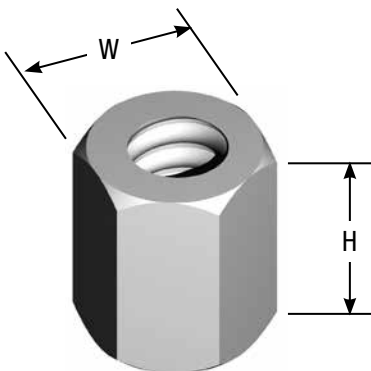

CN-25 COIL NUT - HEAVY DATA			
Diameter	Flat Width (W)	Height (H)	SWL (lbs)
½”	⅞”	1”	9,000
¾”	1-⅛”	1-½”	18,000
1”	1-⅝”	2”	38,000
1-¼”	2”	2-½”	56,000
1-½”	2-⅜”	3”	68,000

Safe working load is based on an approximate 2:1 safety factor.

To Order, Specify: quantity, type and diameter.

CB-2 COIL BOLT

The CB-2 Coil Bolts are available in 1/2" and 3/4" diameters for use with Coil Ties, Coil Inserts and other Meadow Burke products furnished with coil threads. Coil Bolts are manufactured with the fast-threading, self-cleaning coil thread and are available in lengths as needed.

Coil Bolts may be furnished with an integral forged head or with a hex nut welded to a length of continuous coil rod. Standard thread length of the integral forged head Coil Bolt is 4" on the 1/2" diameter and 4-1/2" on all other sizes. For minimum coil penetration, see **CB-2 & CB-4 COIL BOLT PENETRATION DATA TABLE**.

To Order, Specify: quantity, type and bolt diameter.

Use of waterproof, stain resistant grease applied to the bolt shaft will aid in the bolt removal process. Note that Coil Bolts are subject to wear and misuse and should be continually inspected for wear, cracks, bends, overstressing, etc. If there is any indication of these types of problems, the bolt should be discarded.



CB-2 & CB-4 COIL BOLT PENETRATION DATA									
1/2" Diameter		3/4" Diameter		1" Diameter		1-1/4" Diameter		1-1/2" Diameter	
Tension	Shear	Tension	Shear	Tension	Shear	Tension	Shear	Tension	Shear
9,000	6,000	18,000	12,000	38,000	25,000	56,000	37,000	68,000	45,000
Minimum Coil Penetration 2"		Minimum Coil Penetration 2-1/2"		Minimum Coil Penetration 2-1/2"		Minimum Coil Penetration 3"		Minimum Coil Penetration 3"	
Treads per inch 6		Treads per inch 4-1/2		Treads per inch 3-1/2		Treads per inch 3-1/2		Treads per inch 3-1/2	
Min. Root Area Square Inches .1385		Min. Root Area Square Inches .3080		Min. Root Area Square Inches .5410		Min. Root Area Square Inches .9160		-	

Safe working load is based on an approximate 2:1 safety factor.

CB-4 ADJUSTABLE COIL BOLT

The CB-4 Adjustable Coil Bolt consists of a length of Coil Rod with a Coil Nut welded on one end and a free running Coil Nut on the threaded section. This unit simplifies ordering on projects where unusual forming conditions require numerous bolt lengths. The Adjustable Coil Bolt is available in 1/2" and 3/4" diameters in standard 18" and 24" lengths. Other diameters and lengths are available on special order. For minimum coil penetration, see **CB-2 & CB-4 COIL BOLT PENETRATION DATA TABLE**.

To Order, Specify: quantity, type, bolt diameter and length.

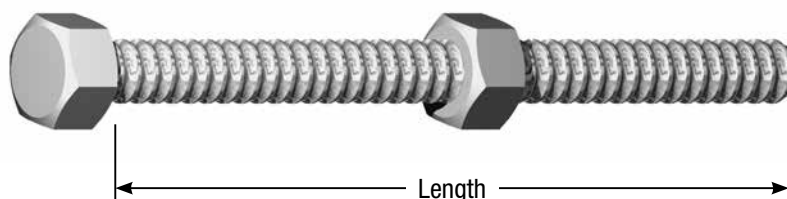

CX-32 SCREED CHAIR – ADJUSTABLE

CH-37 PIPE HOLDER

The CX-32 Screed Chair – Adjustable, is available in ½” diameter x (2-½”, 3-½”, 5-½”) heights for slabs from 4” up to 11-½” and a ¾” diameter x 5-½” height for slabs from 9-½” up to 16”.

The CH-37 Pipe Holder, is available in ½” or ¾” diameter for use with screed chairs to obtain proper slab heights. To adjust the chair and pipe holder height for grade, hold the pipe holder stationary while turning the chair up or down.

CX-32 SCREED CHAIR & CH-37 PIPE HOLDER DATA					
CX-32 Chair #	Screed Chair Size	CH-37 Pipe #	Pipe Holder Size	Slab Thickness	
				Minimum	Maximum
1	½” x 2-½”	0	½” x 1-½”	3-½”	4-½”
1	½” x 2-½”	1	½” x 3”	4-½”	5-½”
2	½” x 3-½”	2	½” x 4”	5-½”	7-½”
3	½” x 5-½”	3	½” x 6”	7-½”	11-½”
4	¾” x 5-½”	4	¾” x 8”	9-½”	13-½”
4	¾” x 5-½”	5	¾” x 12”	13-½”	16-½”

All slab heights shown are based on 1” ID pipe (1-¼” OD)

WARNING: Products shown above are not intended to support mechanical screeding machines. For manual screed operations only.

To Order, Specify: quantity, type, number, diameter, height or length.

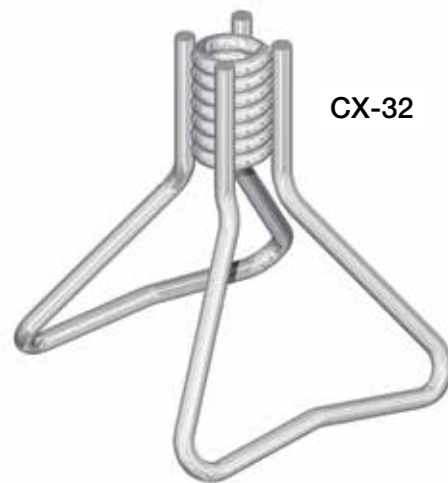

CX-34 SCREED CHAIR – FILL TYPE

CX-38 SCREED CHAIR – DRIVE TYPE

The CX-34 Screed Chair – Fill Type, provides four legs for increased stability when used on compacted fill for slab on grade applications. Available in both ½” and ¾” diameter with heights same as CX-32.

The CX-38 Screed Chair – Drive Type, is designed with heavier wire to permit use in more densely compacted sub bases. This chair also available in both ½” and ¾” diameter with heights same as the CX- 32.

To Order, Specify: quantity, type, diameter and height.

CH-40 SCREED CHAIR – HEAVY DUTY

CH-41 PIPE HOLDER – HEAVY DUTY

CH-42 PIPE HOLDER – HEAVY DUTY W/ SET SCREWS

The CH-40 Screed Chair – Heavy Duty, is designed as a heavy rigid chair based for use with vibratory screed equipment. This chair is made with four heavy legs equally spaced with cross bracing to prevent leg spreading. The heavy duty base features a single 1” diameter free-fit ferrule (no threads). Available heights are shown in the table below.

The CH-41 Pipe Holder has an open style cradle manufactured from ¼” steel and will accept screed pipe up to 2” O.D. Cradle is welded to a 1” diameter coil rod and includes a 1” diameter coil nut. Height adjustment is made by turning the coil nut which raises or lowers the cradle.

The CH-42 has a closed style cradle and is manufactured from ¼” steel and has two set screws that secures the screed pipe. This cradle accepts screed pipe up to 3” O.D. Cradle is welded to a 1” diameter coil rod and includes a 1” diameter coil nut. Height adjustment is made by turning the coil nut which raises or lowers the cradle.

CH-40, CH-41 & CH-42 HEAVY DUTY SCREED SLAB THICKNESS CHART							
Chair #	Chair Height	Pipe Holder # 4 1”x4-½”		Pipe Holder # 5 1”x6-¾”		Pipe Holder # 6 1”x9-¾”	
		Min.	Max.	Min.	Max.	Min.	Max.
7	3-½”	6-½”	8-½”	-	-	-	-
8	5-½”	8”	10”	9”	12-½”	12”	14-½”
9	8-½”	11”	11”	11-½”	15-½”	12”	18”

Heights based on use of 1-½” I.D. pipe (2” O.D.), recommended spacing is 2’0” C/C. Safe working load of 800 lbs is based on an approximate 2:1 safety factor.

To Order, Specify: quantity, type, diameter, height or length.

CS-11 SCREED HOOK

CS-12 SCREED HOOK

The CS-11 & CS-12 Screed Hooks are available for quick positioning of pipe or rebar for screeding purposes. The hooks can be supported by metal stakes or #5 or #6 rebar driven into the fill. The hooks slide up and down for quick positioning and are securely held in place by the integral set screw. Will support up to #10 bars.

To Order, Specify: quantity and type.

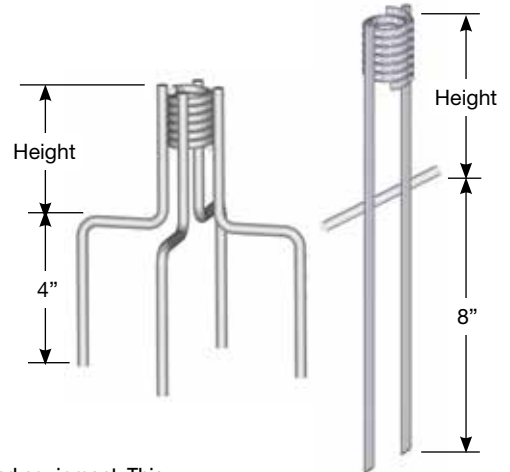

Meadow Burke metal reinforcing bar supports can be manufactured in compliance with American Concrete Institute (ACI) ACI-SP-66, ACI-315 and ACI-315R.

Quality rebar metal supports are available in the following finishes:

- Plastic protected, dipped or tipped.
- Stainless steel protected, ¼” stainless steel tipped.
- Stainless steel protected, ¾” minimum stainless steel tipped.
- Plain wire, no protection.

Also available:

- Epoxy coated meeting AASHTO specifications.
- Epoxy coated with plastic dipped feet.

Notes:

Stainless steel utilized by Meadow Burke in the manufacture of rebar supports conforms to ASTM A-493 and AISI Type 430 and may display some magnetic qualities which shall not be cause for rejection. Heights available in ¼” increments.

METAL REINFORCING BAR SUPPORTS

(SB) SLAB BOLSTER

SLAB BOLSTER DATA			
Type	Available Height	Leg Spacing (C/C)	Length
SB	¾” to 3”	5”	5’-0”

To Order, Specify: quantity, type, height and finish classification.

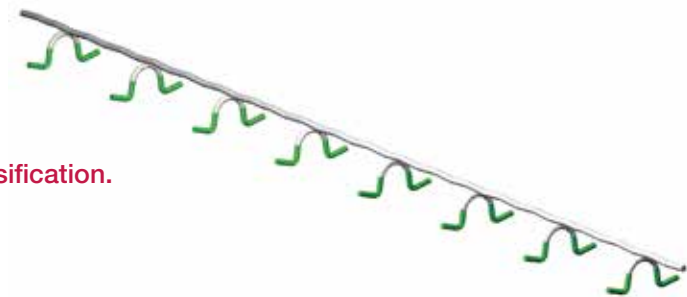

(SBR) SLAB BOLSTER – UPPER

SLAB BOLSTER UPPER			
Type	Available Height	Leg Spacing (C/C)	Length
SBR	¾” to 3”	5”	5’-0”

To Order, Specify: quantity, type, height and finish classification.

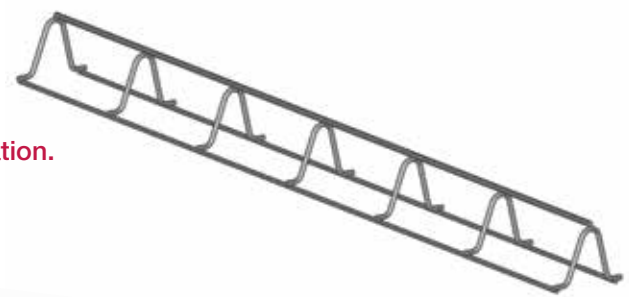

(BB) BEAM BOLSTER

BEAM BOLSTER DATA			
Type	Available Height	Leg Spacing (C/C)	Length
BB	1” to 5”	2-½”	5’-0”

To Order, Specify: quantity, type, height and finish classification.

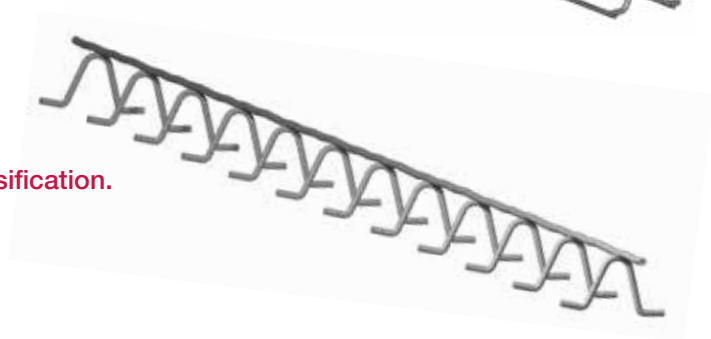

(UBB) BEAM BOLSTER – UPPER

BEAM BOLSTER UPPER DATA			
Type	Available Height	Leg Spacing (C/C)	Length
UBB	1" to 5"	2-½"	5'-0"

To Order, Specify: quantity, type, height and finish classification.



(CHC) CONTINUOUS HIGH CHAIR

CONTINUOUS HIGH CHAIR DATA			
Type	Available Height	Leg Spacing (C/C)	Length
CHC	2" to 20"	8"	5'-0"

To Order, Specify: quantity, type, height and finish classification.

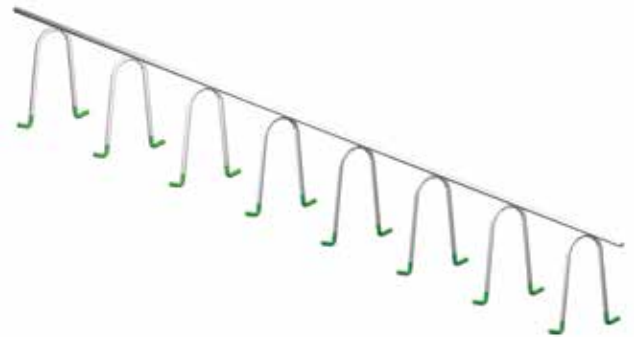

(UCHC) CONTINUOUS HIGH CHAIR – UPPER

CONTINUOUS HIGH CHAIR - UPPER DATA			
Type	Available Height	Leg Spacing (C/C)	Length
UCHC	2" to 20"	8"	5'-0"

To Order, Specify: quantity, type, height and finish classification.

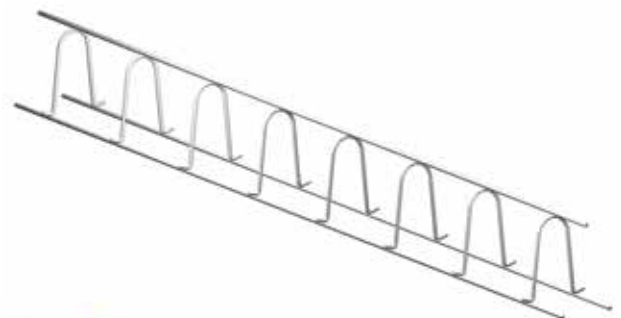

(CHCM) CONTINUOUS HIGH CHAIR – METAL DECK

CONTINUOUS HIGH CHAIR - METAL DECK DATA			
CHCM	Available Height	Leg Spacing (C/C)	Length
Type A	1"-5"	8"	5'-0"
Type B	1"-5"	8"	5'-0"

To Order, Specify: quantity, name, type A or B, leg spread, height.

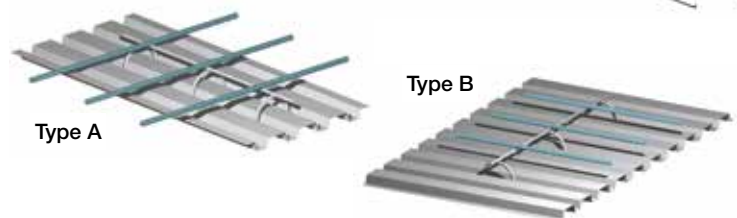

(HCMD) HIGH CHAIR – METAL DECK

HIGH CHAIR - METAL DECK DATA		
Type	Available Height	Height Increments
Type A or B	2" to 15"	¼"

To Order, Specify: quantity, name, type, A, B and C dimension and metal deck profile.

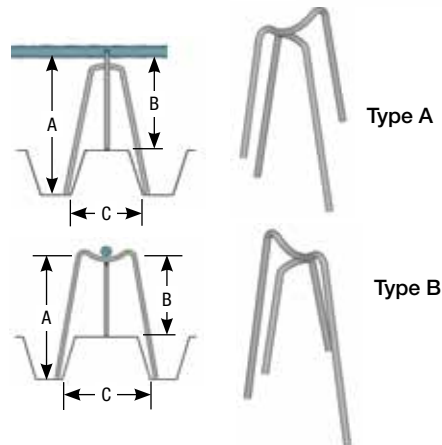

FC-12, (5062) FC-16, (5065) FC-20

FOUNDATION CHAIRS – 12”, 16”, 20”

The FC-12, FC-16 and FC-20 Foundation Chairs unique design places maximum support under each rebar providing unmatched strength in other foundation chairs. Correctly spaced cradle points allow quick, correct placement of the reinforcing steel and provide three full inches of concrete cover under and on both sides of the rebar. Foundation Chairs are available for two-rebar and three-rebar foundation applications. Refer to the Table for dimensional data. Foundation chairs are normally spaced on 5'-0" centers. Optional sand plates are available for sandy soil applications.

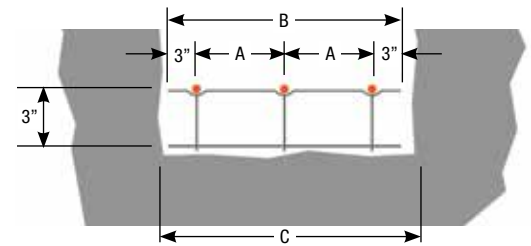
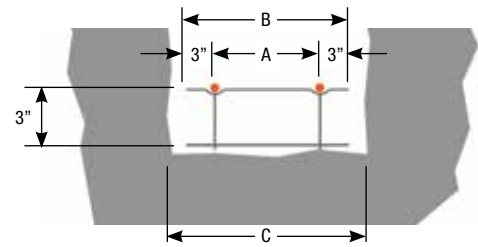
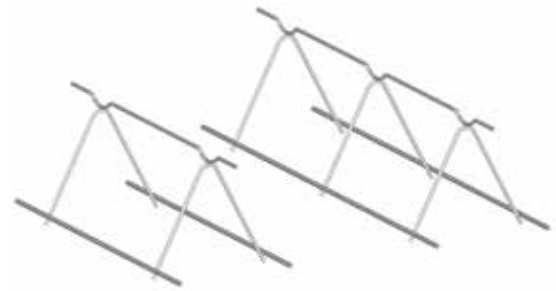

FC-12, FC-16 & FC-20 FOUNDATION CHAIR DATA					
Type	Size	Number of Rebar	"A" Rebar Spacing	"B" Chair Width	"C" Footing Width
FC-12	2-12	2	6"	8-½"	12"
FC-16	3-16	3	5"	13-¼"	16"
FC-20	3-20	3	7"	17-½"	20"

To Order, Specify: quantity, type, number of rebar, length and finish.

(HC) HIGH CHAIR

HIGH CHAIR DATA		
HCMD	Available Height	Height Increments
HC	2" to 40"	¼"

To Order, Specify: quantity, type, height and finish classification.



(Available with metal or plastic dipped sand plate)

(BC) BAR CHAIR

BAR CHAIR DATA		
HCMD	Available Height	Height Increments
BC	¾" to 2"	¼"

To Order, Specify: quantity, type, height and finish classification.



(JC) JOIST CHAIR

JOIST CHAIR DATA		
HCMD	Available Height	Height Increments
BC	¾" to 2"	¼"

To Order, Specify: quantity, type, height and finish classification.



(UJC) JOIST CHAIR – UPPER

JOIST CHAIR - UPPER DATA		
Type	Available Height	Height Increments
UJC	1" to 3-½"	14"

To Order, Specify: quantity, type, height and finish classification.

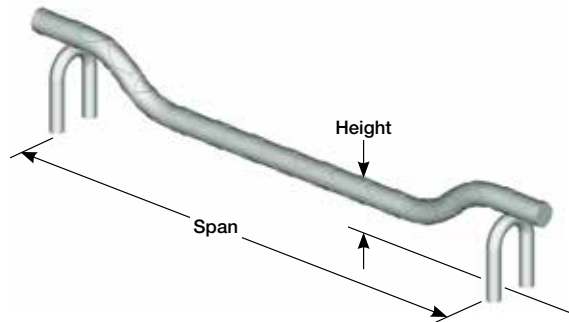

(CS) CONTINUOUS SUPPORT (ZIG-ZAG)

CS Continuous Support (Zig-Zag) is a steel support for horizontal wire mesh, structural fabric or reinforcing bars and an excellent spacer for vertical steel in concrete walls. The support is very stable, it will not slide or tip and has excellent load carrying capacity. It is easy to install and can be bent around voids and/or partitions.

CONTINUOUS HIGH CHAIR - METAL DECK DATA			
Type	Available Height	Height Increments	Length
CS	2" to 12"	¼"	8'-0"

To Order, Specify: quantity, type, height and finish classification.

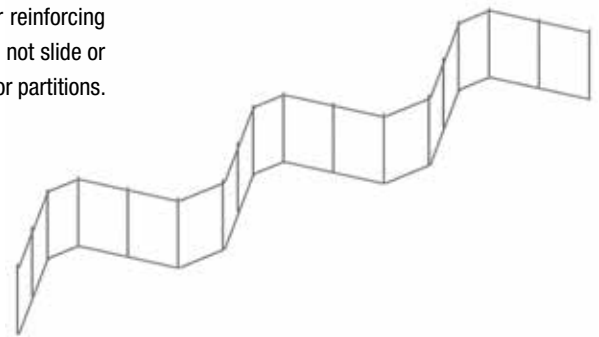

WIRE GIRDER – DOUBLE

The Wire Girder – Double has been designed to quickly and accurately position wire mesh in large slab-on-grade applications. The girder is available in heights from 3" to 9" in 1" increments and in any length up to 40'. Optional snap-on sand plates are available for use on soft, sandy soils and to prevent the girder from turning during concrete placement. When using the girder on a firm casting bed, the snap-on plates are not a necessity but will give better support on slabs exceeding 6" in thickness.

The optional snap-on plates are field installed by simply squeezing the bottom runners of the girder inward until they slip inside the plate tabs. Release of the runners will let them slide under the tabs and be held firmly in place by the tabs.

To Order Wire Girder - Double, Specify: quantity, type, height and length.
To Order Optional Snap-On Plate, Specify: quantity and type.



(SBB) SLAB BEAM BOLSTER

The SB Slab Bolster is fabricated from fiber-filled composite material. They are gray in color to blend with the concrete. The top bar corrugations are on 1" centers to aid rebar placement. It is available in 5' lengths and heights from ¾" to 4" in ¼" increments.

To Order, Specify: quantity, type and height.



X TUFF BEAM BOLSTER

X Tuff Slab Bolster is a new rebar support manufactured in the U.S. using high-performance composite plastic for best-in-class strength and durability. X Tuff Slab Bolster available in a range of heights from ¾" to 4", and 30" lengths.

To Order, Specify: quantity, type and height.



MB TUFF CHAIR

MB Tuff Chair is engineered for strength, durability, recoverability and consistent ruggedness, and are available in a range of heights from ¾" to 10". MB Tuff Chair-Slab Bolster available in a range of heights from ¾" to 4", and 30" lengths.

To Order, Specify: quantity, type and height.



(MBCB) MESH BAR CHAIR WITH BASE

The MBCB Mesh Bar Chair with Base is a special high chair with sand plate for use on soft surfaces and/or slab on grade to correctly position and hold the wire mesh securely in place. Each size chair is designed to service two mesh positioning heights. It is available in heights from 5/8" to 6". The MBCB Mesh Bar Chair with Base can support up to #5 rebar crossing over up to #3 rebar.

To Order, Specify: quantity, type and height.



PC-2 SNAP-ON MESH CHAIR PC-3 SNAP-ON MESH CHAIR WITH BASE

The PC-2 and PC-3 Snap-On Mesh Chairs are economical heavy duty, four sided chairs that quickly snap onto the mesh, 4 ga. to 10 ga., to correctly position it in the slab. The Snap-On Mesh Chair is available in most heights from ¾" to 3" and the Snap-On Mesh Chair with Base is available in heights from 1-½" to 4".

To Order, Specify: quantity, type and height.

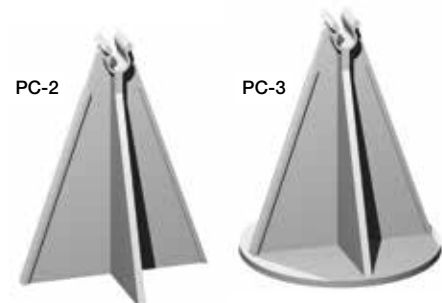

PC-4 SNAP-ON PAVING CHAIR WITH BASE PC-5 SNAP-ON BAR CHAIR

The PC-4 Snap-On Paving Chair and PC-5 Snap-On Bar Chair are substantial plastic bar supports available to support reinforcing steel in various applications. The Snap-On Paving Chair, for #3 to #4 rebar or #4 to #6 rebar (PC-4), is available in heights from ¾" to 7". The Snap-On Bar Chair, for #3 to #7 rebar (PC-5), is available in heights from ¾" to 3".

To Order, Specify: quantity, type and height.

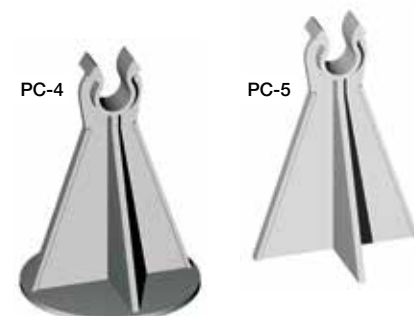



Leviat Locations in North America

California

3611 E La Palma Ave
Anaheim CA 92806

Tel: (800) 804-6565

Florida

6467 S Falkenburg Road
Riverview FL 33578

Tel: (800) 282-7213

Georgia

3080 N Lanier Parkway
Decatur GA 30034

Tel: (800) 241-5662

Iowa

1000 Technology Drive
Boone IA 50036

Tel: (800) 232-1748

New Jersey

526 US Route 46
Teterboro NJ 07608

Tel: (800) 207-7778

Oregon

155 SE Hazel Dell Way
Canby OR 97013

Tel: (888) 232-9991

Pennsylvania

565 Oak Ridge Road
Hazle Township PA 18202

Tel: (800) 550-0060

Texas

7000 Will Rogers Blvd
Fort Worth TX 76140

Tel: (800) 993-9641

Texas

8521 FM 1976
Converse TX 78109

Tel: (800) 323-6896

Contact Information

Customer Service: **(877) 518-7665**

Engineering: **(813) 212-5866**

Email: **info@leviat.us**

Web: **www.leviat.com**

Imagine. Model. Make.

Leviat.com