

Super Lynk SR

Permanent Panel-to-Foundation Connections

Overview

Super Lynk SR is a panel-to-foundation connection system that eliminates the need for epoxy or grouted anchors and field welds.

Super Lynk SR is a fast, strong, and discrete way to permanently connect concrete panels to footings. It requires only a single bolt to make the connection and can easily be concealed within the normal grout line process.

Features

- **Shear Resistance:** The advanced Shear Key is designed to resist shear loads.
- **Simple Installation:** The single bolt connection is simple and quick to install while eliminating the need for epoxy, grout, and in-field welding, saving you time and money.

- **Minimal Profile:** With a profile less than 2½", the Super Lynk SR is discrete relative to alternative connection systems and can easily be concealed by normal backfill and landscaping.
- **Engineered Connection:** The engineered, patented connection system has been developed by Leviat's R&D team to meet ACI 318-14 16.2.4.3 (b).

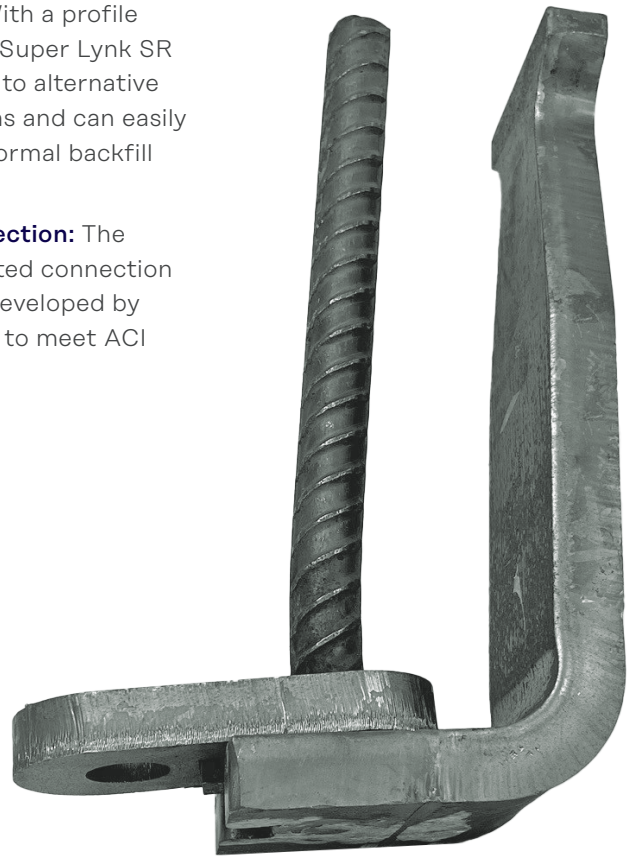

Super Lynk SR

Permanent Panel-to-Foundation Connections

Super Lynk SR includes the tension anchor, MKT SUP-R-BOLT, 1½" MB Tuff Chair, and yellow void former (not pictured)

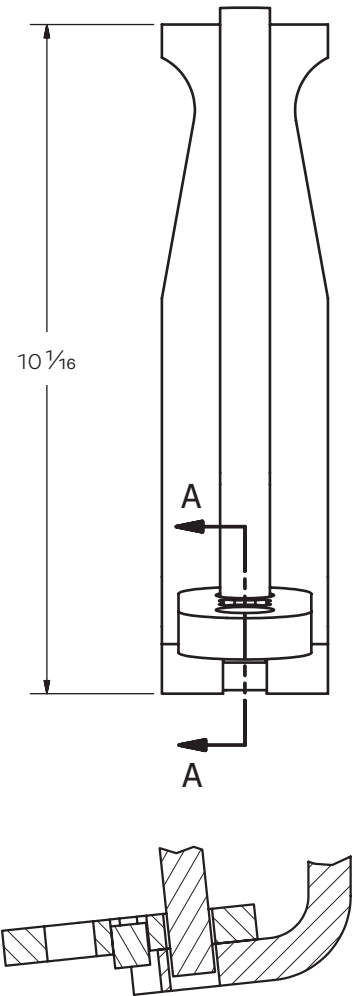
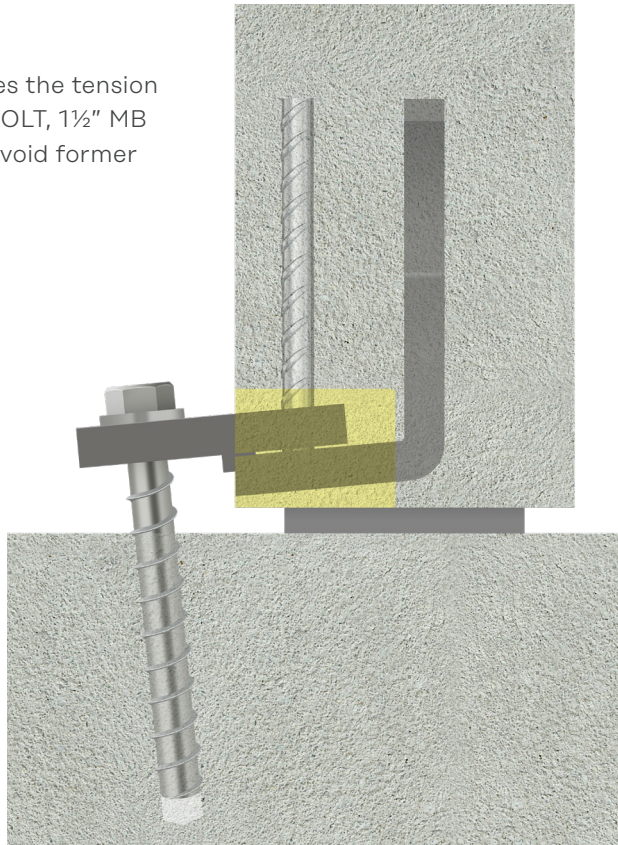

SECTION A-A

Product Data - Super Lynk SR

Item Number	Void Former Color	Tension Load	In-plane Shear Load	Out-of-plane Shear Load	Minimum Panel Thickness	Weight per Unit
MBSLYNKS	Yellow	10,000 lbs	7,000 lbs	7,000 lbs	6"	10½ lbs

1. Published Ultimate Load is based on 3,000 psi concrete
2. Published Ultimate Shear Loads are resultant capacity loads.
3. 8" Minimum edge distance for MKT SUP-R-Bolt.
4. Minimum edge distance to end of panel is 12". Minimum o.c. spacing is 24".
5. Super Lynk SR shipment includes one 1½" tall MB Tuff Chair, one ¾" x 10" MKT SUP-R-BOLT, and yellow void former.
6. Recommended strength reduction factor (Φ) for LRFD design: $\Phi = 0.65$ for both Tension and Shear.

US PATENT 10,577,789

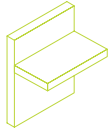

Super Lynk SR

Installation Guide

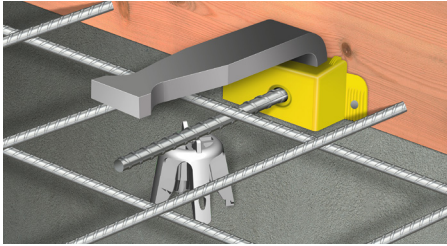

1. Attach to the Form

Attach anchor to the bottom corner of the panel form with screws or nails through the side tabs of the void and into the form. Use a 1½" MB Tuff Chair to support the the anchor and hold embossed side of the void flat to the bottom of the panel and tight to the form.

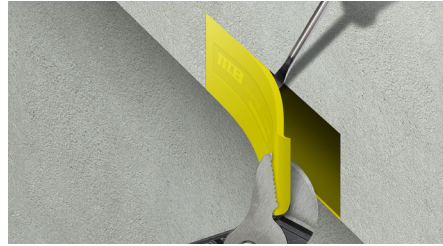

2. Remove Void Cover

Following panel erection, remove the void cover, revealing the Pivot Link.

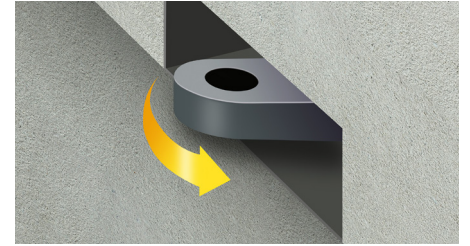

3. Access Pivot Link

Rotate the Pivot Link until it protrudes outside of the panel face and the shear key has fallen into place.

Verify shear key is in place.

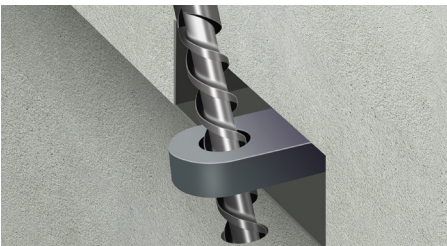

4. Drill the Anchor Hole

Mark the location for the drill hole beneath the eye of the Pivot Link. Using the proper bit size, drill a ¾" hole into the base to the required depth of 9". Drill bit tolerances should meet the requirements of ANSI standard B212.15. Remove dust and debris from hole during drilling (e.g. dust extractor, hollow bit) or following drilling (e.g. suction, forced air) to extract loose particles created during drilling.



5. Anchor into the Foundation

Using a maximum torque of 150 ft-lbs, an impact wrench rating not exceeding 380 ft-lbs, and a 1½" hex socket/driver, mount the MKT SUP-R-BOLT head into the socket. Drive the MKT SUP-R-BOLT until the head of the anchor comes in contact with the Lynk. The screw anchor washer head must be snug after installation. Do not spin the hex socket off the anchor head when disengaging.

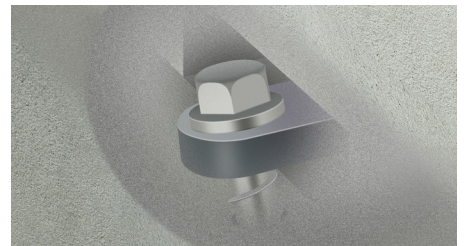

6. Panel is Permanently Connected to the Foundation

The normal grouting process around the bottom of the panel should be followed to include the Super Lynk and bolt head. This grout encasement will fill any gap between the Super Lynk and footing to provide a uniform finish, and avoid any potential for lateral movement.

MKT SUP-R-BOLT is a product of MKT Fastening, LLC